

# Jazzy 1120 2000

Owner's Manual



**How a Power Chair Should Feel!™**

**Pride**  
Mobility Products Corp.

*Exeter, PA  
St. Catharines, ON*

**1-800-800-8586**

[www.pridemobility.com](http://www.pridemobility.com)

# SAFETY GUIDELINES

**Please read and follow all instructions in this owner's manual before attempting to operate your power chair for the first time. If there is anything in this manual you do not understand, or if you require additional assistance for set-up, contact your authorized Pride provider.**

**Using your Pride product safely depends upon your diligence in following the warnings, cautions, and instructions in this owner's manual. Using your Pride product safely also depends upon your own good judgement and/or common sense, as well as that of your provider, caregiver, and/or healthcare professional. Pride is not responsible for injuries and/or damage resulting from any person's failure to follow the warnings, cautions, and instructions in this owner's manual. Pride is not responsible for injuries and/or damage resulting from any person's failure to exercise good judgement and/or common sense.**

**The symbols below are used throughout this owner's manual to identify warnings and cautions. It is very important for you to read and understand them completely.**



**WARNING!** Failure to heed the warnings in this owner's manual may result in personal injury.



**CAUTION!** Failure to heed the cautions in this owner's manual may result in damage to your power chair.

# C O N T E N T S

<b>I. INTRODUCTION</b> .....	4
<b>II. SAFETY</b> .....	6
<b>III. EMI/RFI</b> .....	8
<b>IV. THE JAZZY 1120<sub>2000</sub></b> .....	10
<b>V. ASSEMBLY</b> .....	16
<b>VI. COMFORT ADJUSTMENTS</b> .....	18
Seat Height and Angle .....	18
Armrest Width .....	18
Armrest Angle .....	19
Armrest Height (optional) .....	19
Joystick Extension .....	19
Swing-Away Joystick .....	19
Footrest Height .....	20
Footrest Depth .....	20
Footrest Angle .....	20
Swing-Away Footrests Option .....	20
Elevating Leg Rests Option .....	20
Reclining Seat Option .....	21
Power Elevating Seat Option .....	21
High-back with Headrest (optional) .....	22
Anti-Tip Wheel Adjustment .....	23
<b>VII. DISASSEMBLY</b> .....	24
<b>VIII. OPERATION</b> .....	25
Pilot Controller .....	26
Remote Plus Controller .....	28
Europa Remote Controller .....	31
<b>IX. BATTERIES AND CHARGING</b> .....	35
<b>X. CARE AND MAINTENANCE</b> .....	40
<b>XI. OPTIONAL ACCESSORIES</b> .....	45
<b>XII. WARRANTY</b> .....	47

# I . I N T R O D U C T I O N

Welcome to Pride Mobility Products Corporation (Pride). Congratulations on the purchase of your new Jazzy Power Chair. The Jazzy 1120<sub>2000</sub> design combines the most advanced state-of-the-art components with modern, attractive styling. We are certain that the design features and trouble-free operation of your new Jazzy Power Chair will add convenience to your daily living.

At Pride, your safety is important to us. **Please read and follow all of the instructions in this manual before you attempt to operate your Jazzy for the first time.** These instructions were produced for your benefit. Your understanding of these instructions is essential for the safe operation of your new Jazzy Power Chair.

Pride is not liable for damage to property or personal injury arising out of unsafe use of a Jazzy Power Chair. Pride is also not liable for any property damage or personal injury arising out of the failure of any person and or/user to following the instructions and recommendations set forth in this manual or any other instructions or recommendations contained in other Jazzy related literature issued by Pride or contained on the Jazzy Power Chair itself.

This owner's manual is compiled from the latest specifications and product information available at the time of publication. We reserve the right to make changes as they become necessary. Any changes to our products may cause slight variations between the illustrations and explanations in this manual and the product you had purchased.

If you experience any problems with your Jazzy that your are unable to solve, or if you do not feel capable of safely following any of the instructions and/or recommendations as contained in this manual, please contact your authorized Pride provider for assistance.

Once you understand how to operate and take care of your Jazzy, we are certain that it will give you years of trouble-free service and enjoyment.

## **Information Exchange**

We want to hear your questions, comments, and suggestions about this manual. We would also like to hear about the safety and reliability of your new Jazzy Power Chair, and about the service you received from your authorized Pride provider.

Please notify us of any change of address, so we can keep you apprised of important information about safety, new products, and new options that can increase your ability to use and enjoy your Jazzy. Please feel free to write us at the address below:

Pride Mobility Products Corporation  
Attn: Technical Service Department  
182 Susquehanna Avenue  
Exeter, PA 18643-2694  
1-800-800-8586

# I . I N T R O D U C T I O N

## **Pride Owners Club**

As an owner of a Pride product, you are invited to register your product's warranty and enroll in the Pride Owners Club. You may do so by filling out and returning your enclosed registration card or by visiting Pride's web site at [www.pridemobility.com](http://www.pridemobility.com). As a registered member, each time you visit our site, you will have access to the most interactive and honest educational venue available today for people with mobility needs, their families and friends.

From our home page, click on the button that reads "Owners Club" to enter a page dedicated to current and potential Pride product owners. You will gain access to interviews, stories, recreation ideas, daily living tips, product and funding information, and interactive message boards. On these message boards you are invited to speak with other Pride customers as well as Pride representatives who are available to assist you with any questions or concerns you may have. You will receive a free gift simply for registering with the Pride Owners Club.

## **My Authorized Pride Provider is:**

Name: \_\_\_\_\_

Address: \_\_\_\_\_

Phone Number: \_\_\_\_\_

## **Quick Reference Information:**

Jazzy Model: \_\_\_\_\_

Serial Number: \_\_\_\_\_

Purchase Date: \_\_\_\_\_

*NOTE: If you ever lose or misplace your warranty card or your copy of this manual, call or write to us and we will be glad to send you a new one immediately.*

## II. SAFETY

Your Jazzy 1120<sub>2000</sub> is a state-of-the-art, life-enhancement device designed to increase your mobility. There are certain situations, including some medical conditions, where you will need to practice operating your Jazzy in the presence of an attendant. Below are some safety tips that are designed to help you become accustomed to operating your new Jazzy safely.



**WARNING! Your Jazzy is a motorized vehicle. When you are seated in your Jazzy and you anticipate that you are going to be in a stationary position for an extended period of time, turn off the power. This will prevent unexpected chair movement from inadvertent contact between the end user and joystick.**

### TRANSFERS

Transferring onto and off of your Jazzy requires a good sense of balance. Be sure to have an attendant or health care professional present while learning to properly transfer yourself. To eliminate the possibility of injury, we ask that you verify the following before attempting a transfer:

- Be sure the power is turned off. See VIII. “Operation.”
- Be sure your Jazzy is not in freewheel mode. See IV. “The Jazzy 1120<sub>2000</sub>.”
- Make sure the armrests are flipped up or removed from your Jazzy.
- Flip the footrest up or move the leg rests aside; this helps to keep your feet from getting caught on the footrest or on the leg rests during the transfer.



**WARNING! Avoid putting all of your weight on the footrest. This may cause the Jazzy to tip which may result in injury.**

### MOTOR VEHICLE TRANSPORT

As of this date, there are no standards approved for tie-down systems in a moving vehicle of any type to transport a user while in a power chair.



**WARNING! Always be sure your Jazzy power chair is properly secured when it is being transported. Failure to do so may result in personal injury and/or damage to your Jazzy.**

**WARNING! Pride does not recommend power chair users to be transported in vehicles while seated in their power chairs. Personal injury may result.**

Although your Jazzy may be equipped with a positioning belt, this belt was not designed with the intent of providing proper restraint during motor vehicle transport. Anyone traveling in a motor vehicle should be properly secured into his/her seat with seat belts approved by the vehicle manufacturer.

### WEIGHT LIMITATIONS

Your Jazzy 1120<sub>2000</sub> is rated for a maximum 300-lb. weight limit.



**WARNING! Exceeding the weight limit voids your warranty and may result in personal injury.**

# II. SAFETY

## PUBLIC ROADS AND PARKING LOTS

It may be difficult for motorists to see you when you are seated on your Jazzy. To ensure your safety, always assume you cannot be seen. Wait until your path is clear of traffic, and then proceed with extreme caution.

*NOTE: Many municipalities have laws concerning operating your powered wheelchair on public roads. Be sure to check local laws before attempting to do so.*

## STAIRS AND ESCALATORS

Wheelchairs are not designed to travel up or down stairs or escalators. Always use an elevator.



**WARNING!** If you try to negotiate steps or escalators, you can cause injury to yourself and to others.

## STEPS AND CURBS



**WARNING!** Never attempt to have your Jazzy climb or descend a step or a curb that is higher than four (4) inches.

**WARNING!** Never attempt to have your Jazzy proceed backwards down any step, curb, or other obstacle. Doing so could cause your Jazzy to tip.

## INCLINES AND UNEVEN TERRAIN



**WARNING!** When climbing an incline, do not zigzag or drive at an angle up the face of the incline. Always drive your Jazzy straight up the incline. This greatly reduces the possibility of a tip or a fall. Always exercise extreme caution when negotiating an incline.

**WARNING!** Never travel up or down an incline that can be potentially hazardous (for example, areas covered with snow, ice, or cut grass).

When climbing an incline, try to keep your Jazzy moving. If you must stop, start up again slowly, and then accelerate cautiously. When driving down an incline, do so slowly and in the forward direction only. If your Jazzy starts to move faster than you anticipated or desired it would, allow the chair to come to a complete stop by releasing the joystick. Push the joystick slightly forward and continue traveling slowly down the incline.

## MAXIMUM RECOMMENDED INCLINE

Pride has performed extensive incline testing with the Jazzy. Our results show that the maximum incline your Jazzy can safely climb is five degrees at maximum weight capacity. Five degrees is the angle of most handicap access ramps. Any attempt to climb a steeper slope may put your Jazzy in an unstable position.

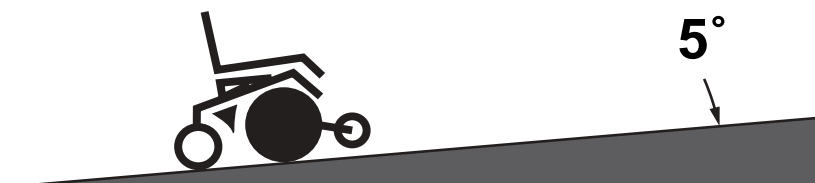

# III. EMI / RFI

Laboratory tests performed by the Food and Drug Administration (FDA) have shown that radio waves can cause unintended motion of powered wheelchairs. Radio waves are a form of electromagnetic energy (EM). When this energy adversely affects the operation of an electronic device, it is called *Electromagnetic Interference (EMI)* or *Radio Frequency Interference (RFI)*.



**WARNING! Radio waves may interfere with the control of powered wheelchairs.**

## **EMI/RFI—FREQUENTLY ASKED QUESTIONS (FAQs)**

The following FAQs summarize what you should know about EMI/RFI. Use this information to minimize the risk that EMI/RFI will affect your powered wheelchair.

### **Where do radio waves come from?**

Radio waves are emitted from the antennas of cellular phones, mobile two-way radios (such as walkie-talkies), radio stations, TV stations, amateur radio (HAM) transmitters, wireless computer links, microwave sources, and paging transmitters. Radio waves are a form of EM. Because electromagnetic energy is more intense closer to the transmitting antenna (source of emission), the EM fields from two-way radios are of special concern to powered wheelchair users.

### **If my powered wheelchair is affected by EMI/RFI, what kind of motion should I expect?**

This is hard to predict. It would depend on a number of factors:

- Strength of the radio waves
- Construction of the powered wheelchair
- Position of the powered wheelchair (whether it is on level ground or on an incline)
- Whether or not the powered wheelchair is in motion

An affected wheelchair's movement can be erratic. It may move by itself or come to a sudden stop. Furthermore, it is possible for EMI/RFI to unexpectedly release the brakes on a powered wheelchair. Some intense sources of EMI/RFI can even damage the control system of your Jazzy.

### **Is there any way to know for sure whether radio waves are responsible for the unintended motion of my powered wheelchair?**

Unfortunately, interference from radio wave sources may be difficult to recognize, since the signals from these sources are invisible and may be intermittent. However, the FDA recommends that you report all incidents of unintended motion or brake release to the powered wheelchair manufacturer and, if possible, note whether there was a radio wave source nearby at the time of the incident.

### **Has anyone been hurt from erratic, unintended motion of powered wheelchairs?**

The FDA has reports of injuries that resulted from the apparent uncontrolled motion of powered wheelchairs. However, it is unclear how many of these incidents were actually caused by radio wave interference.



## III. EMI/RFI

### **Are all powered wheelchairs susceptible to EMI/RFI?**

Each make and model of chair differs in its ability to resist electromagnetic interference. That is, each has a particular level of “immunity” to interference, measured in volts per meter (V/m). A higher immunity level offers greater protection. In other words, a powered wheelchair with a high immunity level is less likely to be affected by a strong radio source than one with a low immunity level.

### **What is the FDA doing about the problem?**

The FDA has written powered wheelchair manufacturers and requested that they test their new products to be sure that they provide a reasonable degree of immunity against EMI/RFI. The letter states that powered wheelchairs should have an immunity of at least 20 V/m. This provides a reasonable degree of protection against the common sources of EMI/RFI.

The FDA has also requested that these manufacturers clearly label their products with the immunity level, or state that the immunity level is not known. The labeling and informational material supplied with the powered wheelchair must explain what the immunity level means, and the labeling or informational material must warn users about the possibility of EMI/RFI and how to avoid it. In addition, the FDA has recommended that manufacturers establish an educational program to inform powered wheelchair users and their caregivers about the problems associated with EMI/RFI, and the actions they can take to minimize the risk. The FDA requested that powered wheelchair manufacturers have these actions implemented by December 2, 1994.

### **What can I do to find out if my powered wheelchair is likely to be affected by EMI/RFI?**

If you’ve had your powered wheelchair for a long time and haven’t experienced any unintended motion, it is not likely that you will have problems in the future. But it is always possible that problems could arise if you are close to a source of radio waves. Therefore, it is very important to be alert to this possibility. The Jazzy meets or exceeds an immunity level of at least 20 V/m.

### **What can I do to reduce the risk that my powered wheelchair could be affected by EMI/RFI?**

Here are some precautions you can take:

- Do not turn on or use hand-held personal communications devices, such as citizens band (CB) radios and cellular phones, while the powered wheelchair is on.
- Be aware of nearby transmitters, such as radio or TV stations and hand-held or mobile two-way radios, and try not to come close to them. For example, if you are in a powered wheelchair with an immunity level of 20 V/m, you should remain at least three feet from a hand-held two-way radio and ten feet from a mobile two-way radio.
- Be aware that adding accessories and/or components, or modifying the powered wheelchair, may make it more susceptible to interference from radio wave sources. There is no easy way to evaluate their effect on the overall immunity of the powered wheelchair.

### **What should I do if my powered wheelchair moves unexpectedly?**

If unintended motion or brake release occurs, turn the powered wheelchair off as soon as it is safe to do so.

### **If my powered wheelchair moves unexpectedly, where should I report this?**

Call Pride at 800-800-8586 to report the incident.

## IV. THE JAZZY 1120<sub>2000</sub>

Your Jazzy has two main assemblies: the seat and the power base. See figure 1. There are a variety of seating options that are designed to accommodate most users. Typically, the seating assembly includes the armrests, seatback, and joystick controller. Your Jazzy may also have some optional accessories attached to it, such as a basket, a cane/crutch holder, a cup holder, or a power seat switch. See XI. "Optional Accessories."

The power base assembly is the heart of your Jazzy. The power base assembly includes two drive wheels, two anti-tip wheels, two rear caster wheels, a power seat connector (optional), harness connectors, and a body shroud. See figures 1 through 5.

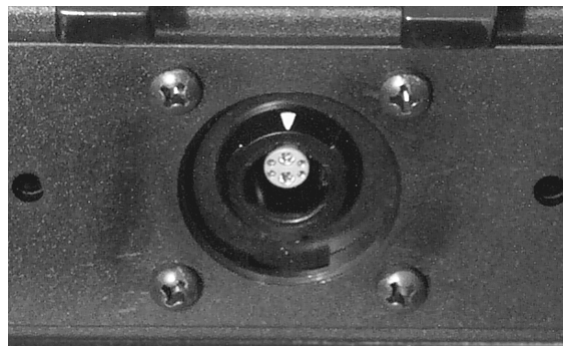

**Figure 1. The Jazzy 1120<sub>2000</sub>**

# IV. THE JAZZY 1120<sub>2000</sub>



**Figure 2. The Jazzy 1120<sub>2000</sub> Rear View**



**Figure 3. Remote Plus Controller Harness Connector**



**Figure 4. Pilot Controller Harness Connector**

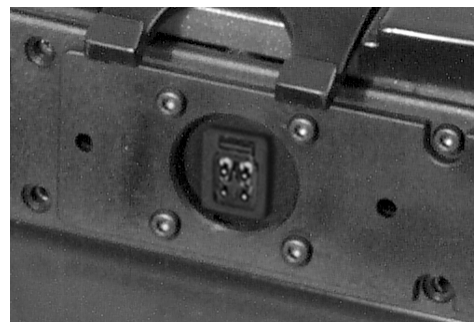

**Figure 5. Europa Remote Controller Harness Connector**

# IV. THE JAZZY 1120<sub>2000</sub>

## UTILITY TRAY

The utility tray is located on the rear of your Jazzy. The utility tray is located underneath the rear sliding door. The utility tray consists of the ammeter, the battery charger plug, the main circuit breaker, accessory connector (optional equipment), and the controller harness connectors. See figure 6.

- **Ammeter:** The ammeter displays the charger's current output in amps. See figure 6. For more information, see IX. "Batteries and Charging" in this manual.
- **Battery Charger Plug:** This plug is used whenever your battery needs recharging. See figure 6.
- **Main Circuit Breaker:** The main circuit breaker is a safety feature built into your Jazzy. See figure 6. When the batteries and the motors are heavily strained (e.g., from excessive loads), the main circuit breaker trips to prevent damage to the motors and the electronics. If the circuit trips, allow your Jazzy to "rest" for approximately one minute. Next, push in the circuit breaker button, turn on the joystick controller, and continue normal operation. If the main circuit breaker continues to trip repeatedly, contact your authorized Pride provider.
- **Accessory Connector (Optional):** This is where the optional harness connects to the controller (power seat, lighting).
- **Controller Harness Connectors:** This is where the joystick connects to the motors, batteries, and charger. If your Jazzy is equipped with a Remote Plus or Europa controller, there is only one connector on the tray. If your Jazzy is equipped with a Pilot controller, there are two connectors on the tray. See figures 3 through 5 to view the controller harness connectors.
- **Power Seat Connector (Optional):** This is for the optional power seat switch. See figure 6.

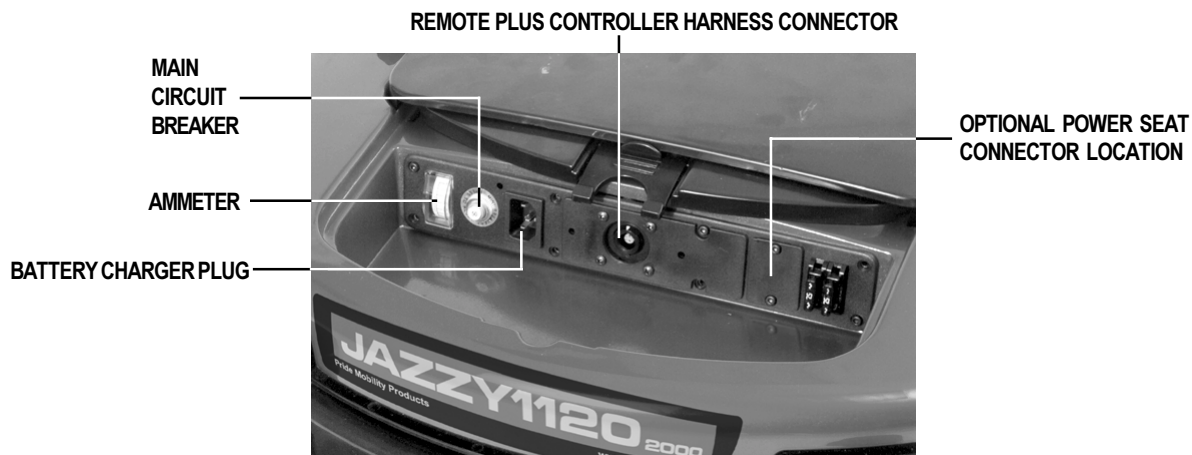

Figure 6. Utility Tray

# IV. THE JAZZY 1120<sub>2000</sub>

## FREEWHEEL LEVER

For your convenience, your Jazzy is equipped with a freewheel lever. See figures 7 and 8. This lever allows you to disengage the drive motors and maneuver the chair manually.



**WARNING!** Do not use your Jazzy while the drive motors are disengaged unless you are in the presence of an attendant! Do not disengage the drive motors when your Jazzy is on an incline. The chair could roll down on its own, causing injury!

### To disengage the drive and place chair in freewheel:

1. Move the safety latch up. See figure 7.
2. Pull the freewheel lever up.

### To engage the drive and take chair out of freewheel:

- Push the freewheel lever down. See figure 8.



**CAUTION!** It is important to remember that when your Jazzy is in freewheel mode, the braking system is disengaged.

If a lever is difficult to move in either direction, rock your Jazzy back and forth slightly. The lever should then move to the desired position.

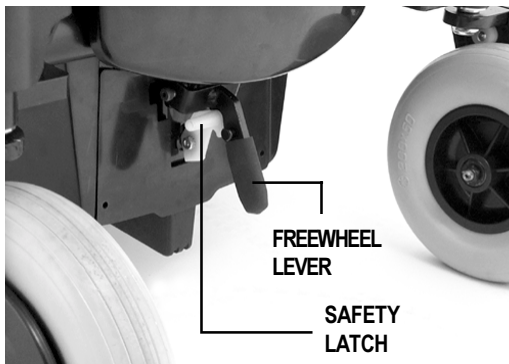

**Figure 7. Drive Disengaged**

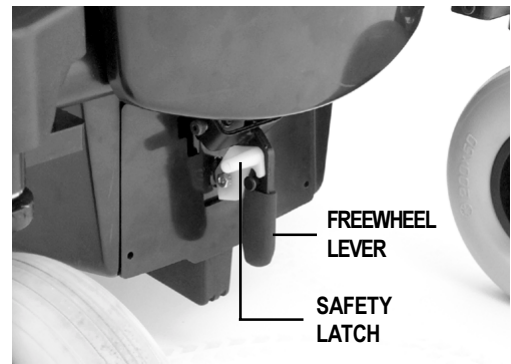

**Figure 8. Drive Engaged**

# IV. THE JAZZY 1120<sub>2000</sub>

## ACTIVE-TRAC SYSTEM

Your Jazzy is equipped with an Active-Trac System (ATS). ATS is a suspension system designed to make your Jazzy traverse different types of terrain and obstacles while maintaining smooth operation. With ATS, your front anti-tip wheels work in conjunction with your motor suspension to help you maneuver over obstacles.

As your front anti-tip wheels come in contact with an obstacle, the front anti-tip wheel assembly is drawn upward. At the same time, your motors are forced downward. This allows the motors to push the Jazzy over an obstacle and limits the possibility of your power chair becoming “hung up” on the obstacle.

ATS also helps in day-to-day operating conditions. For instance, when you release the joystick your Jazzy begins to slow down. As the chair slows down, the front anti-tip wheels will automatically drop toward the ground. This will reduce the forward tip that is typically encountered with center-wheel drive chairs.

## REAR SUSPENSION

Your Jazzy 1120<sub>2000</sub> is equipped with Rear Suspension. See figure 9. This suspension system works in conjunction with the ATS and is designed to maintain a smooth ride when driving over rough terrain and up and down curbs. This system works by allowing the caster forks to respond to weight transfers and uneven terrain. The rear caster wheels will pivot as you drive over obstacles. This system also enhances performance when the front anti-tip wheels are set lower to the surface.

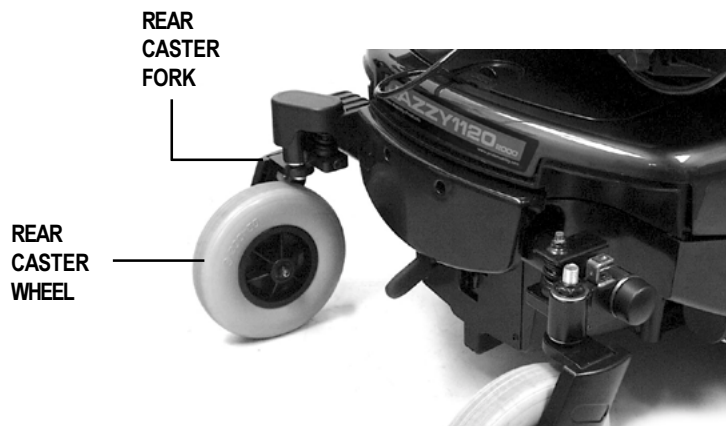

**Figure 9. Rear Suspension System**

# IV. THE JAZZY 1120<sub>2000</sub>

<b>Specifications</b>	
Suspension:	Full suspension with Active-Trac Rear Caster Suspension
Drive Wheels:	14 in., pneumatic (solid tires are optional)
Rear Casters:	8 in., solid, rear articulating
Anti-tip:	6 in., solid, front mounted
Maximum Speed:	6 mph
Brakes:	“Intelligent Braking,” electronic regenerative, disc park brake
Ground Clearance:	3.5 in.
Turning Radius:	19.5 in.
Overall Size:	Length: 39.5 in. Width: 25.4 in.
Seating Options:	Medium Back (standard) High-back with headrest Reclining Seat Versa Seat Versa Tilt Power Elevating Option
Drive Train:	Two motor, mid wheel
Batteries:	Two 12-volt, Group 24 batteries (NF-22 batteries for the power seat option)
Range:	Up to 25 miles
Battery Charger:	Onboard Off-board (optional)
Electronics:	50-amp P & G Pilot Controller 70-amp P & G Remote Plus Controller 70-amp Dynamic Europa Remote Controller
Weight Capacity:	300 lbs.
Jazzy Weights:	Base: 83 lbs. Seat: 29 lbs. Batteries: 44 lbs. each
Warranty:	Lifetime limited warranty on frame Two-year warranty on electronics Eighteen-month warranty on drive motors



# V. ASSEMBLY

## SEAT ANGLE ADJUSTMENT

The seatback can be adjusted at four different angles, depending on user preference. A 90°, 102°, 105°, or 107° angle can be set.

### To adjust the seat angle:

1. Use a hex key and a 3/8-in. wrench to remove the adjustable bolt on both seat hinges.
2. Set at desired angle.
3. Reinstall the bolt and tighten.

## SEAT INSTALLATION (SEAT WITH H-FRAME)

The standard seat installation method incorporates the seat frame (H-frame) and four (4) adjustable seatposts located on the power base.

### To install the seat:

1. Set the seat on the rear seat towers. See figure 10.
2. Push the seat back and down until the latches engage on the front seat towers. See figure 10.
3. Plug the controller cable into the connector on the utility tray. See figure 11.
4. Plug the power seat switch cable (if so equipped) into the connector on the utility tray.
5. Secure the controller cable to the armrest receiver with one or more wire ties.
6. Route the cable to ensure that the cable cannot be pinched in the seat hinge.

## JOYSTICK INSTALLATION

Depending on the various configurations and options you have chosen for your Jazzy, it may have been shipped without the joystick installed in the armrest.

### To install the joystick:

1. Use a 3/16-in. hex key to loosen the setscrew. See figure 12.
2. Slide the joystick mounting bracket into or out of the armrest to the desired position.
3. Retighten the setscrew.

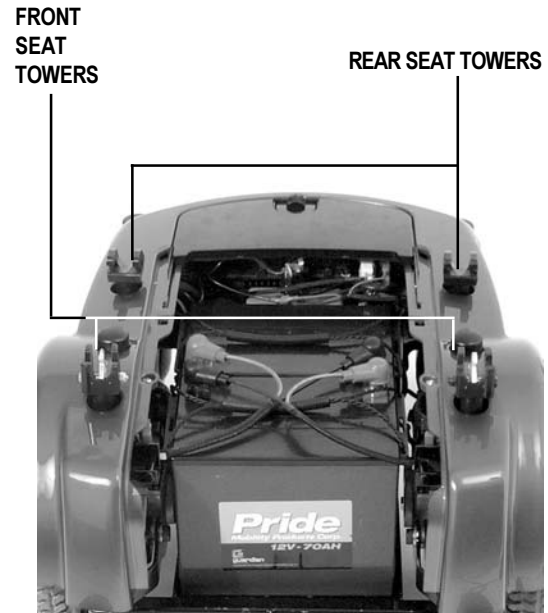

Figure 10. Seat Towers



Figure 11. Controller Cable Connection



# V. ASSEMBLY

## POWER SEAT OPTION INSTALLATION

Your Jazzy may be equipped with the power seat option. While the seat itself may be any one of the styles offered for this model, the way the seat base attaches to the Jazzy power base is different.

### To install the power seat:

1. Align the seat shaft to the hole in the actuator. See figure 13.
2. Insert seat into actuator and push the seat lever forward.
3. Lock seat into place.

## VERSA SEAT OR VERSA TILT OPTION

If your Jazzy is equipped with a Versa Seat or Versa Tilt, please refer to the instruction manual supplied with the Versa Seat/Versa Tilt.

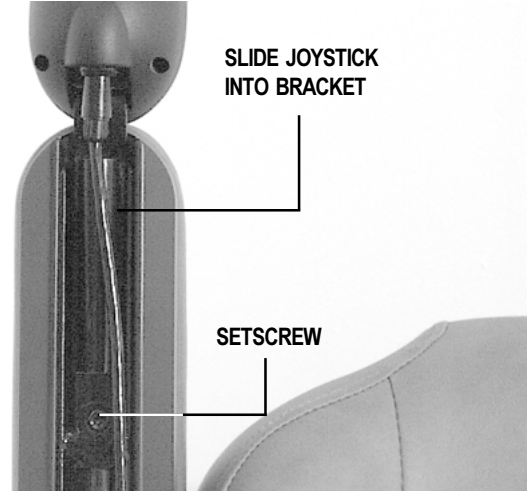

Figure 12. Joystick

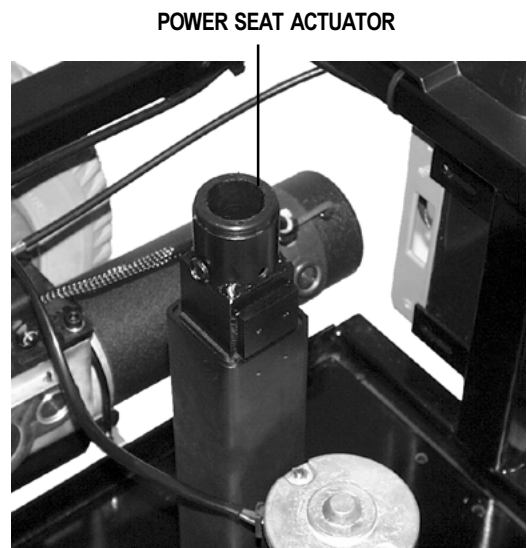

Figure 13. Power Seat Actuator

# VI. COMFORT ADJUSTMENTS

Once you are familiar with your Jazzy's operation, you may find the need to adjust your seating position. There are some adjustments you can make to increase your comfort, such as seat height and angle, armrest width, angle and height, joystick position, and footrest height, depth and angle.



**CAUTION!** If your Jazzy was configured at your local Pride provider or service center, please consult your health care professional before changing the seat position or making any other adjustment. Some adjustments may degrade your Jazzy's performance and safety by changing its center of gravity.

## SEAT HEIGHT AND ANGLE

You can change the seat height by one of two ways: either manually or automatically. (If equipped with the optional Power Elevating Seat, see "Power Elevating Seat Option" later in this section.)

### To change the seat height:

1. Remove the seat. See VII. "Disassembly."
2. Remove the foot frame.
3. Remove intermediate shroud by releasing two 1/4 turn fasteners.
4. Remove the ball detent pin from each seat tower. See figure 14.
5. Raise or lower each seat tower to the desired position.
6. Install the ball detent pin into each seat tower.
7. Reinstall intermediate shroud and foot frame.
8. Install the seat.

### To change the seat angle:

1. Remove the seat hinge bolt with a 5/32-in. hex key and a 7/16-in. wrench. See figure 15.
2. Adjust seatback to desired angle and reinsert the seat hinge bolt.
3. Tighten bolts with the hex key and wrench.

## ARMREST WIDTH

### To change the armrest width:

1. Locate the two knobs on the armrest receiver bracket. See figure 16.
2. Loosen the knobs.
3. Slide the armrests in or out, to the desired width.
4. Tighten the knobs.

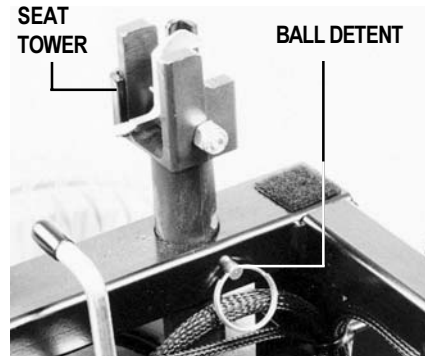

Figure 14. Seat Height

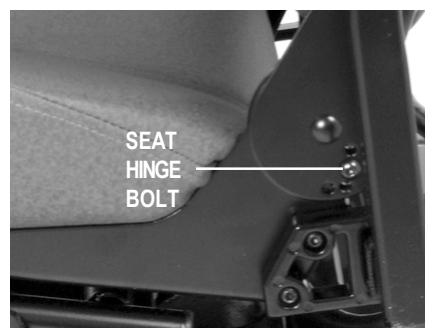

Figure 15. Seat Angle



Figure 16. Armrest Width

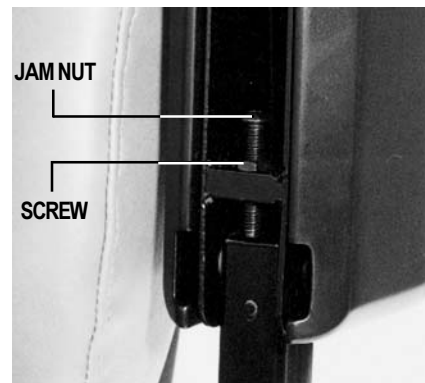

Figure 17. Armrest Angle

# VI. COMFORT ADJUSTMENTS

## ARMREST ANGLE

You can adjust the armrest angle to fit your specific needs.

### To change the armrest angle:

1. Lift the armrest straight up so that it is perpendicular to the floor.
2. Use a 7/16-in. wrench to loosen the jam nut. See figure 17.
3. Use a 5/32-in. hex key to loosen the adjusting screw.
4. Turn the screw clockwise to lower the front of the armrest, or turn the screw counterclockwise to raise the front of the armrest.
5. Lock the adjusting screw into place by tightening the jam nut.

## ARMREST HEIGHT (OPTIONAL)

Your Jazzy may be equipped with height-adjustable armrests.

### To change the armrest height:

1. Loosen the setscrew located underneath the armrest using a 3/16-in. hex key.
2. Remove the ball detent pin from the armrest.
3. Move the armrest up or down to the desired height.
4. Align the holes and reinsert the ball detent pin.
5. Retighten the setscrew.

## JOYSTICK EXTENSION

The joystick control can easily slide out away from the armrest or in toward the armrest.

### To extend the joystick:

1. Use a 3/16-in. hex key to loosen the setscrew. See figure 18.
2. Slide the joystick mounting bracket into or out of the armrest to the desired position.
3. Retighten the setscrew.

## SWING-AWAY JOYSTICK

Your Jazzy may be equipped with a swing-away joystick. This option enables you to move the joystick from the front of the armrest to the side of the armrest, without disconnecting it. See figures 19 and 20.

The joystick can be mounted to the left or right side of your Jazzy. Contact your authorized Pride provider.

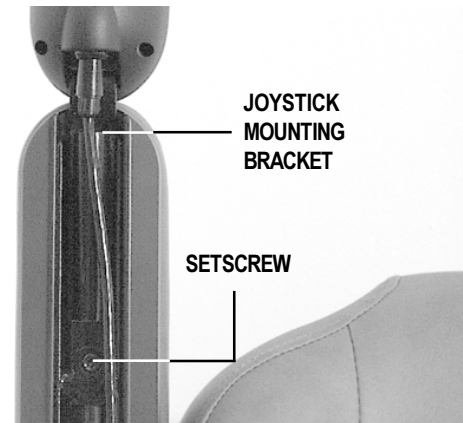

Figure 18. Joystick Extension



Figure 19. Swing-Away Joystick (Forward Position)



Figure 20. Swing-Away Joystick (Retracted Position)

# VI. COMFORT ADJUSTMENTS

## FOOTREST HEIGHT

The footrest height is easily adjusted to one of six different heights in 1-in. increments.

### To raise or lower the footrest:

1. Remove the nuts and bolts from bracket. See figure 21.
2. Raise or lower the footrest to the desired height.
3. Reinstall the bolts and nuts into the footrest bracket and tighten.

## FOOTREST DEPTH

### To adjust the footrest depth:

1. Remove the nuts and bolts from the bracket. See figure 21.
2. Move the footrest in or out to the desired depth.
3. Reinstall the 5/16-in. detent pin into the bracket and tighten.

## FOOTREST ANGLE

You can adjust the angle of the footrest with a 3/16-in. hex key. See figure 22.

### To adjust the footrest angle:

1. Turn the setscrew clockwise to raise the front of the footrest.
2. Turn the setscrew counterclockwise to lower the front of the footrest.

## SWING-AWAY FOOTRESTS OPTION

Swing-away footrests (SFRs) are an option. They enable you to swing the footrest to the side before transferring from your Jazzy.

### To swing the footrests:

1. Push in the release lever. See figure 23.
2. Swing the footrest off to the side.

## ELEVATING LEG RESTS OPTION

Elevating Leg Rests (ELRs) offer an infinite range of adjustment between 0° – 70° for the leg angle and a legrest adjustment range of 15 – 20 in.

### To adjust the ELR angle:

1. Press the release lever. See figure 24.
2. Move the leg rest to the desired angle.

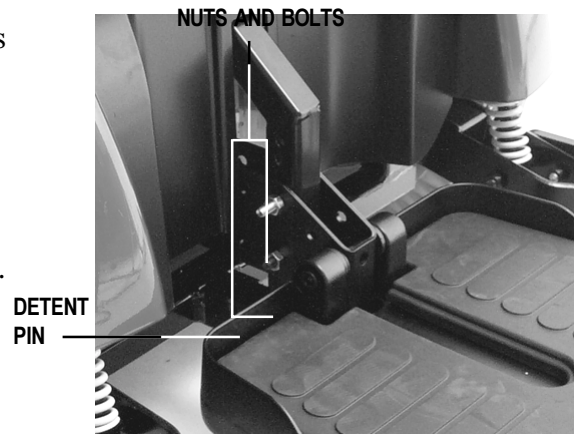

Figure 21. Footrest Height

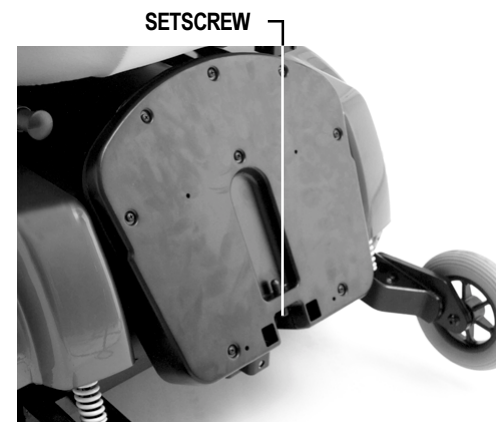

Figure 22. Footrest Angle



Figure 23. Swing-Away Footrests

# VI. COMFORT ADJUSTMENTS

## To adjust the ELR height:

1. Remove the two screws from the side of each leg rest extension. See figure 25.
2. Slide the leg rest in or out to the desired length.
4. Reinstall the two screws on each leg rest extension.

## RECLINING SEAT OPTION

If your Jazzy is equipped with a reclining seat (see figure 26), you can adjust the seatback angle and the armrest angle.

## To adjust the seatback angle:

1. Press down on the seatback release lever. See figure 27.
2. Move the seatback down or up to the desired position.
3. Release the seatback release lever.

## To adjust the armrest angle:

Refer to “Armrest Angle” earlier in this section.

## POWER ELEVATING SEAT OPTION

If your Jazzy is equipped with a power elevating seat, you can change the seat height automatically. The seat height switch is located either on the armrest (Pilot or Europa controllers), or on the joystick (Remote Plus or Europa controllers).

## To change the seat height:

1. Press forward on the power seat switch to raise the seat. See figure 28.
2. Pull back on the power seat switch to lower the seat.

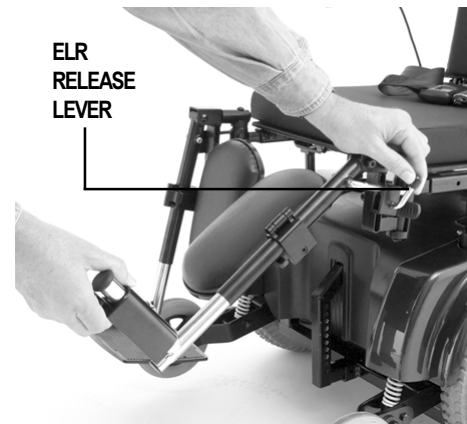

Figure 24. Elevating Leg Rests

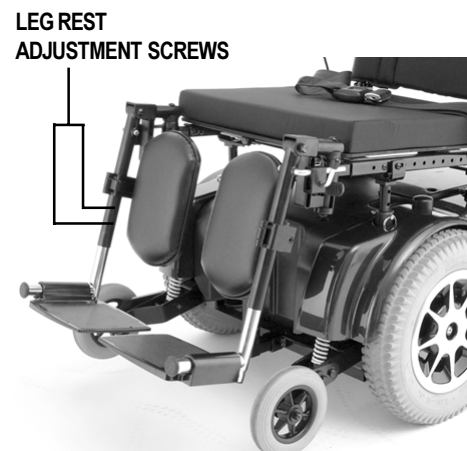

Figure 25. Elevating Leg Rests



Figure 26. Reclining Seat



# VI. COMFORT ADJUSTMENTS

## Power Seat warnings and Cautions



**WARNING!** Never raise the seat from its lowest position on an inclined surface. Failure to heed this warning can result in your Jazzy tipping over and causing injury.

**WARNING!** Never raise the seat from its lowest position when operating your Jazzy on bumpy or uneven surfaces. Failure to heed this warning can result in your Jazzy tipping over and causing injury.

**WARNING!** Never raise the power elevating seat when the chair is in freewheel mode.



Figure 27. Seatback Angle



**CAUTION!** The power seat option is intended for use while your Jazzy is on level surfaces only.

**CAUTION!** Always fasten the safety belt when operating the power elevating seat. The power elevating seat option is equipped with a system that reduces your Jazzy's speed by one half when the seat is elevated more than 1 – 2 inches. Always check to be sure this system is operating properly before using your Jazzy.

**CAUTION!** Operate your Jazzy only on a flat level surface whenever the elevating seat is raised from its lowest position.

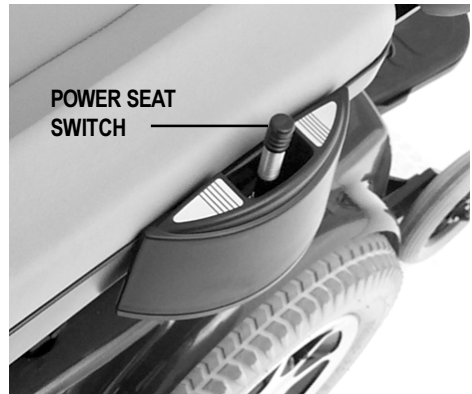

Figure 28. Seat Height

## HIGH-BACK WITH HEADREST (OPTIONAL)

If your Jazzy is equipped with the deluxe high-back seat, you can adjust the headrest height.

### To adjust the headrest height:

1. Push in the headrest release button.
2. Move the headrest up or down to the desired position.

# VI. COMFORT ADJUSTMENTS

## ANTI-TIP WHEEL ADJUSTMENT

The anti-tip wheels are designed to give your Jazzy increased stability on rough surfaces. The anti-tip wheels are preset at the factory to a height of 1/2-in. off the ground. This setting is for smooth surfaces or indoor use only. If you plan on using your Jazzy on rough surfaces, it may be necessary to adjust the anti-tip wheels to better suit your needs. The anti-tip wheels may need adjustment if either of the following occur:

- When coming to a stop, your Jazzy tips forward excessively.
- The anti-tip wheels constantly rub the ground.

*NOTE: Each drive tire must have at least 30 - 35 lbs. of air pressure in order for the anti-tip wheels to be properly adjusted.*



**WARNING! Overinflating tires can cause them to explode and can result in personal injury.**

### To adjust the anti-tip wheels:

1. Place a 1/2-in. wrench on the inner locknut of the anti-tip bracket located right after your shock strut. See figure 29.
2. Turn the locknut counterclockwise to loosen.
3. Place your 1/2-in. wrench on the adjustable cam located on the other side of the locknut. See figure 30.
4. To adjust the anti-tip upward, turn the cam counterclockwise. To adjust the anti-tip downward, turn the cam clockwise.



**Figure 29. Anti-Tip Wheel Adjustment**



**Figure 30. Anti-Tip Wheel Adjustment**



**WARNING! The higher you raise the anti-tip wheels, the more tendency your Jazzy has to tilt forward when coming to a stop. You can compensate for this by making a small adjustment to the pre-programmed deceleration setting in the controller or by moving the seat assembly further to the rear of your Jazzy. Failure to do so may result in personal injury.**

# VII. DISASSEMBLY

## SEAT REMOVAL

You may wish to remove the seat for transportation. If you have a Versa Seat, please refer to the Versa Seat Installation and Adjustment guide.

### To remove the seat:

1. Turn the power off.
2. Make sure your Jazzy is not in freewheel mode.
3. Unplug the main wire harness behind the seat.
4. Simultaneously depress the two plungers on the front of the seat frame while lifting the front of the seat. See figure 31.
5. Lift the seat up and gently lower it back onto the front seat towers.
6. Pull the seat forward and lift it off of the rear seat towers.



Figure 31. Removing the Seat

### To remove a power seat:

1. Release seat by moving the seat release lever rearward.
2. Lift up the power seat plate.
3. Lift the seat off of the actuator.

## FOOT FRAME REMOVAL

The foot frame helps protect the Jazzy components from the environment. See figure 32. You must remove the foot frame in order to change the batteries and check the cable connections.

### To remove the foot frame:

1. Turn the power off.
2. Make sure your Jazzy is not in freewheel mode. See IV. "The Jazzy 1120<sub>2000</sub>."
3. Locate the 5/15-in. pin at the base of the footplate bracket and remove.
4. Lift the foot frame straight up approximately 2 inches and pull toward you.



Figure 32. Removing the Foot Frame



**WARNING!** Your Jazzy 1120<sub>2000</sub> batteries weigh approximately 44 lbs. each. Lifting weight above your capability could result in injury.

## BATTERY REMOVAL

### To remove the batteries:

1. Turn the power off.
2. Remove the foot frame.
3. Disconnect the quick disconnects by pulling them toward you.
4. You can now remove the batteries from your Jazzy.



# VIII. OPERATION

## JOYSTICK AND CONTROLLER

Your Jazzy is operated by your joystick and controller. The Jazzy 1120<sub>2000</sub> is currently available with one of three controller options: Pilot, Remote Plus, or Europa. See figures 33 through 35. Refer to the text that applies to the controller you own.



**Figure 33. Pilot Controller**



**Figure 34. Remote Plus Controller**



**Figure 35. Europa Remote Controller**

### To operate your Jazzy:

1. Turn the power on (push the on/off key). The battery condition meter lights, indicating the present charge of your battery.
2. Push the joystick in the direction you wish to move. The further you push the joystick from the neutral (center) position, the faster your Jazzy moves.

## CONTROLLER FUNCTIONS

The controller translates the speed and the directional information from the joystick for the motors. It has self-diagnostic features that are designed to search for potential problems at the rate of 100 times per second. If the controller detects a problem in the wheelchair's electrical system, the wheelchair may, depending on the severity of the problem, stop functioning (see "Trouble Codes").

The controller is designed to maximize user safety under normal operating conditions. This controller, however, cannot take into account circumstances that put your Jazzy outside of its normal operating environment as described within this manual. It is very important that you follow the precautions described within this manual.

# VIII. OPERATION

## PILOT CONTROLLER

The Pilot controller is an integral controller. See figure 36. This means that the joystick is housed in the same enclosure as the controller module. This assembly is mounted on the seat arm. The Pilot controller is connected to the motors, the batteries, and the battery charger through a cable that connects to the utility tray.

### Joystick Functions

The joystick function is similar for all controller configurations. The joystick controls the direction and speed of the wheelchair. See figure 37. When you move the joystick from the neutral (center) position, the electromagnetic brakes release and allow the wheelchair to move. The further you push the joystick from its neutral position, the faster your Jazzy moves. When you release the joystick and allow it to return to the neutral position, you engage the electromagnetic brakes. This causes the chair to decelerate and come to a complete stop. If your Jazzy begins to move in an unexpected manner, immediately release the joystick. Unless the joystick is damaged, this action should stop your Jazzy.



**WARNING! Do not use the on/off key to stop the chair. This may cause injury.**



**Figure 36. Pilot Controller**

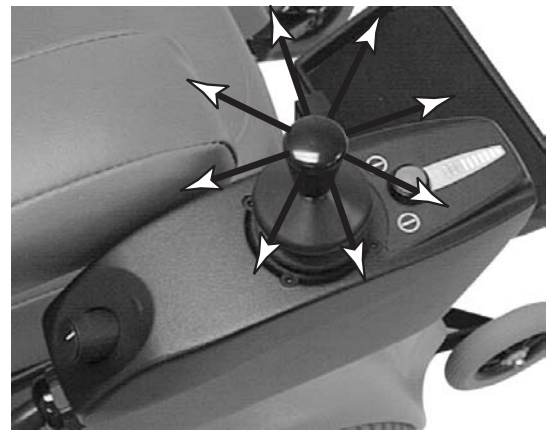

**Figure 37. Joystick Movement**

### Speed and Response Adjustment

The Pilot joystick controller is equipped with a speed and response adjustment knob that allows you to select the speed and response settings best suited to your requirements and environment. See figure 36. When you increase the speed (clockwise) or decrease the speed (counterclockwise), appropriate changes are automatically made to the sensitivity.

*NOTE: We recommend that the first few times you operate your Jazzy you turn the speed and response adjustment knob to the slowest setting until you become familiar with your new powered wheelchair.*

### Battery Condition Meter

The battery condition meter is located immediately in front of the joystick. See figure 36. This enables you to monitor battery life. The battery condition meter indicates the approximate amount of battery life left.

- Red, yellow, and green bars indicate that the batteries are fully charged.
- Red and yellow bars indicate that you should charge the batteries.
- Red bars indicate that you should charge the batteries as soon as possible, because low battery voltage may cause your Jazzy to become inoperative.

*NOTE: When the batteries approach a discharged state, the first red bar will begin to slowly flash, reminding you the batteries need to be charged immediately!*

# VIII. OPERATION

## CHARGER INHIBIT PLUG CONNECTION

The charger inhibit plug on the utility tray is coded with colored dots. See figure 38. The dots are positioned so that you align the flat side of the male connector with the flat side of the female connector before making the connection.



Figure 38. Charger Inhibit Plug



**CAUTION!** Failure to properly align the connectors can result in damage to the controller, the charger harness, and the connectors.

## THERMAL ROLLBACK

Jazzy controllers are equipped with a thermal rollback circuit. This circuit monitors the temperature of the motors and the controller. In the event that the motors or the controller become excessively hot (above 122° F), the controller reduces the motor voltage. For every degree above 122° F, the controller reduces the voltage by 5 volts. This reduces your Jazzy's speed and allows the electrical components to cool down. When the temperature returns to a safe level, your Jazzy resumes its normal speed.

## TROUBLE CODES

In addition to indicating the current state of battery charge, the battery condition meter can also indicate possible problems with your Jazzy. The battery condition meter has ten individual bars. The bars are meant to provide information by the number of bars that are flashing. If the meter is flashing rapidly, the controller may be indicating a fault. For instance, the very first red bar flashing rapidly indicates the battery voltage is nearly depleted. The following is a list of the possible errors signified by the rapidly flashing meter lights.

Flashing Bars	Diagnosis	Solution
10 Green	High Battery Voltage	Check Batteries
9 Green	Solenoid Brake Fault	Check Motor/Brake Wiring
8 Green	Possible Controller Fault	See Authorized Provider Service Center
7 Yellow	Possible Joystick Fault	See Authorized Provider Service Center
6 Yellow	Inhibit Active	Unplug Charger/Check Connections
5 Yellow	Right Motor Wiring Fault	Check Right Motor Wiring
4 Yellow	Right Motor Disconnected	Check Right Motor Wiring
3 Red	Left Motor Wiring Fault	Check Left Motor Wiring
2 Red	Left Motor Disconnected	Check Left Motor Wiring
1 Red	Low Battery Voltage	Check Batteries/Battery Wiring

If you cannot resolve your problem, see an authorized Pride provider or service center.

# VIII. OPERATION

## REMOTE PLUS CONTROLLER

The Remote Plus controller system consists of the joystick (see figure 39) and the controller box. The joystick sends signals to the controller box through a cable attached to the back of the joystick. This cable connects to the controller box through the utility tray. The Remote Plus joystick is typically located at the end of either the right or the left armrest. The Remote Plus controller box is located underneath the front of the power base.

### Joystick Functions

The joystick function is similar for all controller configurations. The joystick controls the direction and speed of the wheelchair. See figure 40. When you move the joystick from the neutral (center) position, the electromagnetic brakes release and allow the wheelchair to move. The further you push the joystick from its neutral position, the faster your Jazzy moves. When you release the joystick and allow it to return to the neutral position, you engage the electromagnetic brakes. This causes the chair to decelerate and come to a complete stop. If your Jazzy begins to move in an unexpected manner, immediately release the joystick. Unless the joystick is damaged, this action should stop your Jazzy.



**WARNING! Do not use the on/off key to stop the chair. This may cause injury.**

### Battery Condition Meter

The battery condition meter consists of ten LEDs over the speed indicator. See figure 39. These lights are an accurate indication of your usable battery capacity. They also alert you of any faults found within your unit. See “Trouble Codes.”

### On/Off Key

The on/off key turns your unit on and off.

### Horn Key

This key activates the horn.

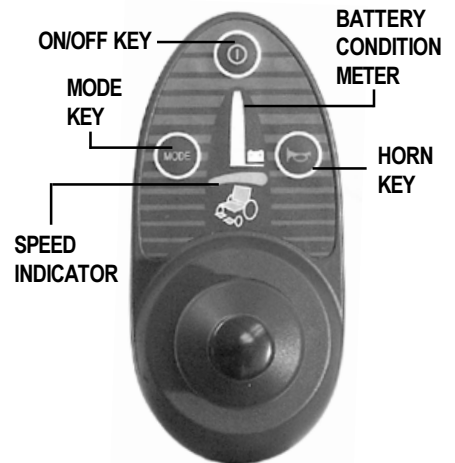

**Figure 39. Remote Plus Joystick Features**

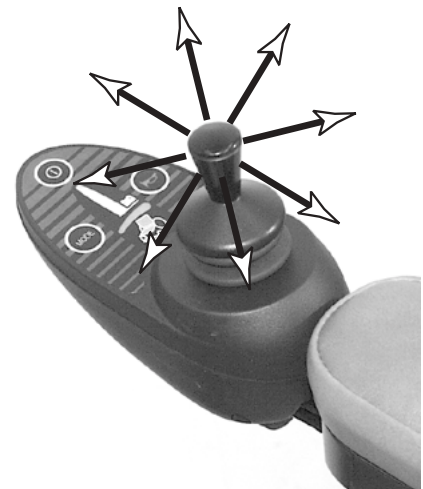

**Figure 40. Joystick Movement**

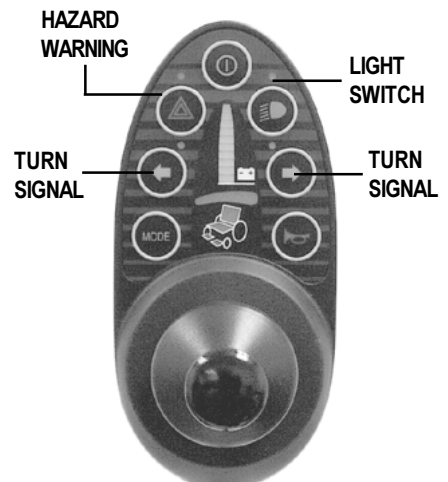

**Figure 41. Remote Plus Optional Features**

# VIII. OPERATION

## Speed and Actuator Adjustments

The Remote Plus joystick controller is equipped with a mode key and a speed indicator. See figure 39. The mode key allows you to access different wheelchair functions. Activating the mode key allows you to adjust the maximum wheelchair speed. To increase or decrease the overall speed, activate the mode key once. Pushing the joystick to the right will increase the speed setting. Pushing the joystick to the left will decrease the speed setting. The speed indicator LEDs will light up from left to right. When one LED is lit, the speed is in the slowest setting. When all five LEDs are lit, the speed is in the fastest setting. After selecting your desired speed, activate the mode key again to return to drive or simply activate the joystick in the forward or reverse direction and your Jazzy will operate at the selected speed setting.

*NOTE: We recommend that the first few times you operate your Jazzy you turn the speed and response adjustment knob to the slowest setting until you become familiar with your new powered wheelchair.*

If your Jazzy is equipped with power seat functions, you can access seat control by pressing the mode key twice. Push the joystick to the right to toggle to your desired seat function. The LED will light in various positions indicating which seat function is active. When the LED is lit in the appropriate section, push the joystick forward to raise the actuator and pull the joystick in reverse to lower the actuator. To return to drive, activate the mode key again.

## SLEEP MODE

Your Remote Plus controller has a sleep mode feature. Sleep mode is a built-in circuit that automatically shuts off the main power if the joystick is not moved in any direction for approximately five minutes. The battery condition lights on the joystick indicate sleep mode by blinking once every five seconds. To restore power and continue, push the on/off key twice.

## THERMAL ROLLBACK

Jazzy controllers are equipped with a thermal rollback circuit. This circuit monitors the temperature of the motors and the controller. In the event that the motors or the controller become excessively hot (above 122° F), the controller reduces the motor voltage. For every degree above 122° F, the controller reduces the voltage by 5 volts. This reduces your Jazzy's speed and allows the electrical components to cool down. When the temperature returns to a safe level, your Jazzy resumes its normal speed.

## TROUBLE CODES

In addition to indicating the current state of battery charge, the battery condition meter can also indicate possible problems with your Jazzy. The battery condition meter has ten individual bars. The bars provide information by the number of bars that are flashing. If the meter is flashing rapidly, the controller may be indicating a fault. For instance, the very first red bar flashing rapidly indicates the battery voltage is nearly depleted. The following is a list of the possible errors signified by the rapidly flashing meter lights.

# VIII. OPERATION

Flashing Bars	Diagnosis	Solution
10 Green	High Battery Voltage	Check Batteries
9 Green	Solenoid Brake Fault	Check Motor/Brake Wiring
8 Green	Possible Controller Fault	See Authorized Provider Service Center
7 Yellow	Possible Joystick Fault	See Authorized Provider Service Center
6 Yellow	Inhibit Active	Unplug Charger/Check Connections
5 Yellow	Right Motor Wiring Fault	Check Right Motor Wiring
4 Yellow	Right Motor Disconnected	Check Right Motor Wiring
3 Red	Left Motor Wiring Fault	Check Left Motor Wiring
2 Red	Left Motor Disconnected	Check Left Motor Wiring
1 Red	Low Battery Voltage	Check Batteries/Battery Wiring

If you cannot resolve your problem, see an authorized Pride provider or service center.

## REMOTE PLUS OPTIONAL FEATURES

See figure 41 to reference the following optional features:

- **Light switch:** If your Jazzy is equipped with the deluxe lighting package, there is a light switch located on the joystick controller. When your Jazzy is powered on, the light switch activates the lights.
- **Turn signals:** The arrow keys activate the turn signals regardless of whether or not your Jazzy is powered off or on.
- **Hazard warning:** This key operates the hazard lights.
- **Power elevating seat up/down (not shown):** These keys eliminate the need for an additional power elevating seat switch.

# VIII. OPERATION

## EUROPA REMOTE CONTROLLER

The Europa Remote controller system consists of the joystick (see figure 42) and the power module. This means that all of the programming is done within the joystick and the power module reacts accordingly. The power module is located underneath the front of the power base. The Europa joystick is typically located at the end of either the right or the left armrest.

### Joystick Functions

The joystick function is similar for all controller configurations. The joystick controls the direction and speed of the wheelchair. See figure 43. When you move the joystick from the neutral (center) position, the electromagnetic brakes release and allow the wheelchair to move. The further you push the joystick from its neutral position, the faster your Jazzy moves. When you release the joystick and allow it to return to the neutral position, you engage the electromagnetic brakes. This causes the chair to decelerate and come to a complete stop. If your Jazzy begins to move in an unexpected manner, immediately release the joystick. Unless the joystick is damaged, this action should stop your Jazzy.

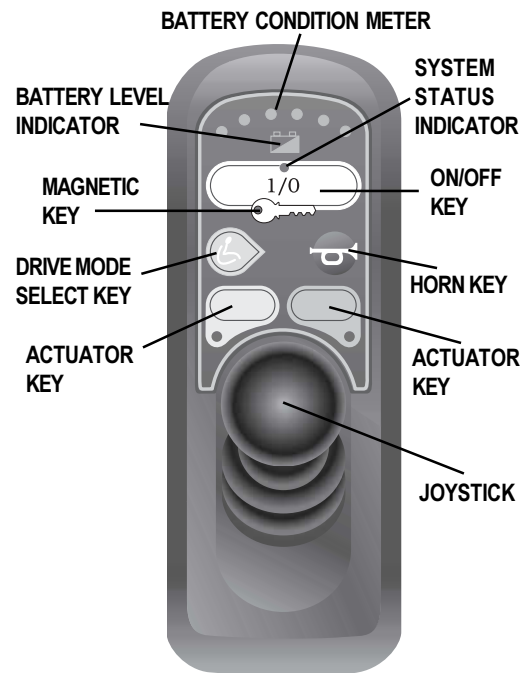

**Figure 42. Europa Remote Controller**



**WARNING! Do not use the on/off key to stop the chair. This may cause injury.**

### Battery Condition Meter

The battery condition meter consists of six LEDs arranged in an arc over the battery level indicator icon. See figure 42. From left to right, the first two are red, the second two are orange, and the last two are green. These lights are an accurate indication of your usable battery capacity. If the battery has at least 85% of its rated capacity, all of the LEDs will be on. As the battery voltage drops, the number of LEDs reduces from right to left. When the battery capacity drops to 10% or below, all of the LEDs flash at the rate of one per second.

### Magnetic Locking Area

The Europa keypad is equipped with a feature that enables you to “lockout” unauthorized users. For this function, you need the magnetic key supplied with your Jazzy. If you lose this key, contact your authorized Pride provider.

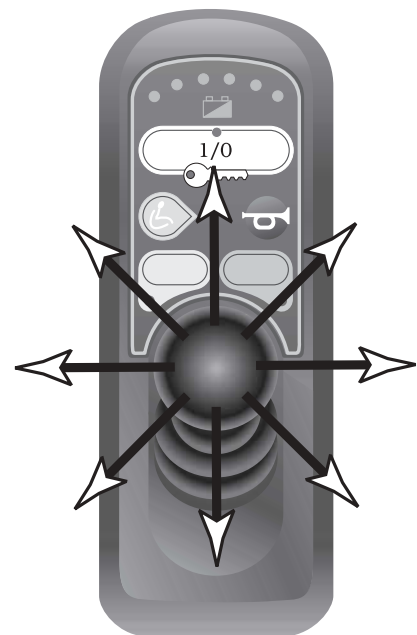

**Figure 43. Joystick Movement**



# VIII. OPERATION

## To arm the lockout system:

1. Hold the magnetic key on or near the key symbol. The controller beeps and automatically powers down. No LEDs should be on.
2. Press the on/off key to power up the chair. The key LED flashes, but you will not be able to drive the power chair because the controller is still locked.
3. Hold the magnetic key on or near the key symbol again to unlock the system. When the key LED stops flashing, you may drive your Jazzy.

If you turn on the controller while it is locked and don't unlock it after one minute, the controller automatically turns itself off.

## On/Off Key

This key switches the system power on and off.

## Horn Key

This key activates the horn.

## System Status Indicator

This LED indicates system status. It is normally on when the system is powered up and off when the system is powered down. It also flashes trouble codes when the system detects a fault. See "Trouble Codes."

## Drive Mode Select Key

This key enables you to select a drive program. This mode also consists of a seven-segment LED that displays the drive program. It also displays whether or not the inhibit is enabled and flashes if there is an OONAPU or DX/Remote fault. See "Out Of Neutral At Power Up."

## Drive Mode Indicator (not shown)

Your Jazzy controller was pre-programmed at the factory for five drive modes: 1 (slowest) to 5 (fastest). The program mode is indicated by a number in the center of the keypad. Press the Drive Mode Select Key to change the mode.

*NOTE: We recommend that the first few times you operate your Jazzy you have your drive mode on the slowest setting until you become familiar with your new powered wheelchair.*

## BATTERY SAVER FEATURE

When the battery capacity drops to below 21V (typically two LEDs), the controller reduces wheelchair performance to conserve battery power.



# VIII. OPERATION

## **OUT OF NEUTRAL AT POWER UP**

The Europa Remote Controller is equipped with Out Of Neutral At Power Up (OONAPU). If you power up the system and the joystick is *not* in the neutral position, the System Status Indicator flashes rapidly for either as long as the joystick is out of the neutral position or for five seconds. If this happens and all the segments on the system status indicator flash, you may have set trouble code 1.

## **ACTUATOR KEYS**

These keys can control up to five actuators independently. You can control them through either of the two actuator keys or you may select the actuator through drive program mode 0. These actuators may be power elevating seats, tilt-in-space seats, power reclining seats, indicator lights, or headlights and taillights.

### **To control actuator movement with either of the two actuator keys:**

1. Press the actuator key to activate the actuator.
2. Move the joystick beyond half its travel in either the forward or reverse direction to move the actuator.

### **To use the joystick to control the actuators:**

1. Press the Drive Mode Select key until you get to 0.
2. Move the joystick to either the left or right turning position to scroll through the options which are A, b, C, d, or E.
3. Select an option.
4. Move the joystick beyond half its travel in either the forward or reverse direction to move the actuator.

## **SLEEP MODE**

The Jazzy controller features a sleep mode, which is a built-in circuit that automatically shuts off the main power if the joystick is not moved in any direction for a specific amount of time. This time factor is programmed into your joystick console. The battery condition lights on the joystick indicate sleep mode by blinking once every five seconds. To restore power and continue, push the on/off key twice.

## **THERMAL ROLLBACK**

Jazzy controllers are equipped with a thermal rollback circuit. This circuit monitors the temperature of the motors and controller. In the event the motors or controller become excessively hot (above 122° F), the controller reduces the motor voltage. For every degree above 122° F, the controller reduces the voltage by 5 volts. This reduces your speed and allows the components to cool down. When the temperature returns to a safe level, your Jazzy resumes its normal speed.

# VIII. OPERATION

## TROUBLE CODES

Your controller is programmed to detect faults within its own system. If something happens to the controller system that prevents your Jazzy from operating, you should see a trouble code. This is indicated by the System Status Indicator flashing a number of times, then pausing for two seconds, then flashing again. Faults that affect the safety of your Jazzy cause the chair to stop, while others allow the Jazzy to operate. Some trouble codes stop if the condition corrects itself. Others can only be cleared by powering down the chair, then powering it up again.

Before you perform any of the electrical connection corrective actions listed in the following table, make sure that you have fully charged batteries and you power down the system. In each case, if the corrective action does not work, contact your authorized Pride provider or service center.

Code	Title	Corrective Action
1	DX Module Fault	Turn the controller off, then on again. If this does not work, check the connections at the joystick, the power module, and any other accessory module that your Jazzy may have. If this still does not work, contact your local Pride provider.
2	DX Accessory Fault	Power down the Jazzy and check all the connections to your accessories. You may have a shorted circuit in one of these connections (e.g., a light bulb is shorted or open).
3	Left Motor Fault	Check the connection between the power module and the left motor. There may be a short or bad connection. The motor itself may be bad.
4	Right Motor Fault	Check the connection between the power module and the right motor. There may be a short or bad connection. The motor itself may be bad.
5	Left Park Brake Fault	Check the connection between the power module and the left motor. There may be a short or bad connection.
6	Right Park Brake Fault	Check the connection between the power module and the right motor. There may be a short or bad connection.
7	Low Battery Fault	Check the battery connections and terminals. Check that the circuit breaker is not tripped. Reset it if necessary.
8	Overvoltage Fault	Contact your service center.
9	CANL Fault	Contact your service center.
10	CANH Fault	Contact your service center.
11	Stall Timeout Fault	Turn the system off, then turn it on again.
12	Module Mismatch	Contact your service center.

# IX. BATTERIES AND CHARGING

## BATTERIES

Your Jazzy uses two long-lasting, 12-volt, deep-cycle batteries. These batteries are sealed and maintenance free. Since they are sealed, there is no need to check the electrolyte (fluid) level. Deep-cycle batteries are designed to handle a longer and deeper discharge. Though they are similar in appearance to automotive batteries, they are not interchangeable. Automotive batteries are not designed to handle a long, deep discharge, and also are unsafe for use in powered wheelchairs.



**WARNING! Battery posts, terminals, and related accessories contain lead and lead compounds. Wash hands after handling.**

## CHARGING THE BATTERIES

The battery charger is essential in providing long life for your Jazzy batteries. The battery charger is designed to optimize your Jazzy's performance by charging the batteries safely, quickly, and easily. The charging system consists of the battery charger, the charger fuse, and the ammeter. The onboard charger is located underneath the utility tray. The ammeter and charger fuse are located on the utility tray for easy viewing. See figures 44 and 45. The ammeter indicates the rate of charge being administered to fully recharge the batteries. It is also a good indication of whether or not the charger is working. The ammeter and the charger are only functional when the charger power cord is plugged into a wall outlet.

*NOTE: To ensure prolonged life, recharge your Jazzy's batteries with the supplied onboard or the supplied off-board charging system. Do not use an automotive-type battery charger.*

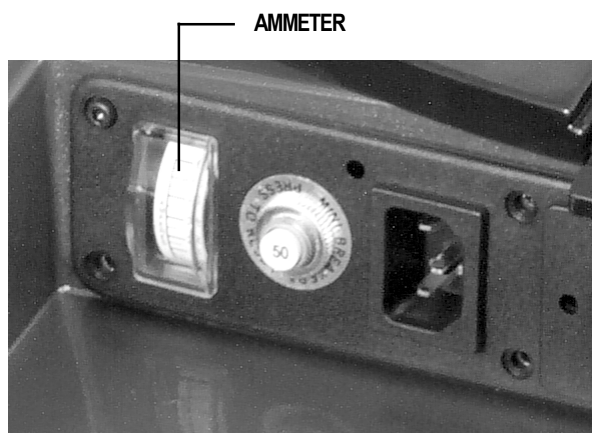

**Figure 44. Ammeter**

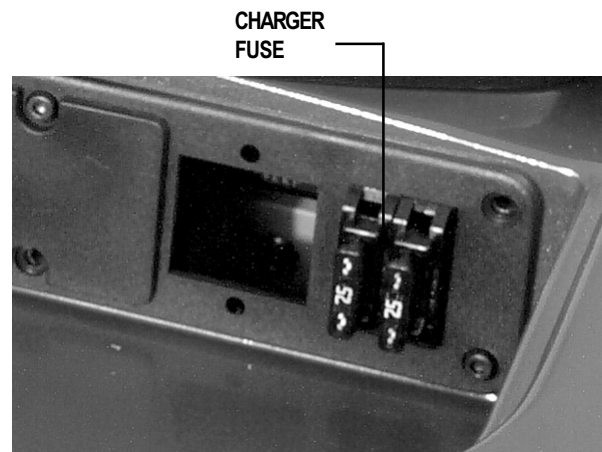

**Figure 45. Charger Fuse**

# IX. BATTERIES AND CHARGING



**WARNING! Never use an extension cord to plug in your battery charger. Plug the charger directly into a properly wired standard wall outlet.**

## **To charge the batteries using the onboard charger:**

1. Position the rear of your Jazzy close to a standard wall outlet.
2. Be certain the controller power is turned off and the freewheel levers are in the engaged position. See IV. “The Jazzy 1120<sub>2000</sub>.”
3. Slide the rear cover forward.
4. Extend the charger power cord and plug it into the wall outlet. The Jazzy incorporates an inhibit function that disables the powered wheelchair when the charger is plugged into a wall outlet.
5. The ammeter indicates how much charge is needed to fully charge the batteries. Wait about a minute for the charger to warm up. The ammeter may move as high as 5.5 amps, then gradually move back down to 0 amps as the batteries charge.
6. We recommend you charge the batteries for 8 to 14 hours. As the batteries charge, the ammeter needle slowly drops to zero. When the batteries are fully charged, the needle vibrates on or near the zero mark on the ammeter scale.
7. When your Jazzy’s batteries are fully charged, you can unplug the power cord from the wall outlet, wind it up using the hook and loop strap, and place the cord back into the rear tray.
8. Replace the rear cover.

## **To charge the batteries using the off-board charger:**

1. Position your Jazzy next to a standard wall outlet.
2. Be certain the controller power is turned off.
3. Remove the run plug located on the utility tray.
4. Plug the 3-pin extension cable into the charger, then into the utility tray connector.
5. Plug the charger into the wall outlet.
6. The ammeter indicates how much charge is needed to fully charge the batteries. Wait about a minute for the charger to warm up. The ammeter should move all the way up to 5 amps, then gradually move back down to 0 amps.
7. We recommend you charge the batteries for 8 to 14 hours. As the batteries charge, the ammeter needle slowly drops to zero. When the batteries are fully charged, the needle vibrates on or near zero on the ammeter scale.
8. When your Jazzy’s batteries are fully charged, disconnect the charger cord from the wall outlet.
9. Disconnect the charger from the rear utility tray.
10. Reconnect the run plug into its connector.

*NOTE: If the run plug is not reconnected, your Jazzy will not run.*

11. Replace the rear cover.

# IX. BATTERIES AND CHARGING

## **BATTERY BREAK-IN**

### **To break in new batteries for maximum efficiency:**

1. Fully recharge any new battery prior to its initial use. This brings the battery up to about 90% of its peak performance level.
2. Operate your Jazzy about the house and yard. Move slowly at first, and don't stray too far until you become accustomed to the controls and break in the batteries.
3. Give the batteries another full charge of 8 to 14 hours and operate your Jazzy again. The batteries should now perform at over 90% of their potential.
4. After four or five charging cycles, the batteries top off at 100% charge and last for an extended period.

## **BATTERIES AND CHARGING—FREQUENTLY ASKED QUESTIONS (FAQs)**

### **How does the charger work?**

The battery charger takes the standard wall outlet voltage of 120 VAC (alternating current) and converts it to 24 VDC (direct current). The Jazzy batteries use direct current to run your powered wheelchair. When the battery voltage is low, the charger works harder to charge the battery. This is why the charging ammeter initially reads 5 or more amps. As the battery voltage approaches full charge, the charger doesn't work as hard to complete the charging cycle. This explains why the charging ammeter drops as it approaches a full charge. When the battery is fully charged, the amperage from the charger is nearly at zero. This is how the charger maintains a charge but does not overcharge the battery. Your Jazzy's charger will not operate after the batteries have been discharged to nearly zero voltage. If this happens, call your authorized Pride provider for assistance.

### **Can I use a different battery charger?**

Use only the charger supplied with the Jazzy. It is the safest, most efficient tool to charge the batteries. We do not recommend using other types of chargers.

### **How often must I charge the batteries?**

Many factors come into play when deciding how often to charge the batteries. You may use your Jazzy all day on a daily basis or you may not use it for weeks at a time.

#### **■ Daily Use**

If you use your Jazzy on a daily basis, charge the batteries as soon as you are finished. Your Jazzy will be ready each morning to give you a full day's service. It is recommended that you charge the batteries 8 to 14 hours after daily use. Do not charge the batteries for more than 24 hours at a charging cycle.

#### **■ Infrequent Use**

If you use your Jazzy infrequently (once a week or less), you should charge the batteries at least once per week for 12 to 14 hours.

*NOTE: Keep your batteries fully charged and avoid deeply discharging your batteries. Do not charge the batteries for more than 24 hours at a charging cycle.*

# IX. BATTERIES AND CHARGING

## How can I get maximum range or distance per charge?

Rarely do you have an ideal driving situation such as smooth, flat, hard terrain with no wind, hills, or curves. More often you are presented with hills, sidewalk cracks, uneven and loosely packed surfaces, curves, and wind. All of these factors affect the distance or running time per battery charge. The following are a few suggestions for obtaining the maximum range per charge.

- Always fully charge the batteries prior to your trip.
- Maintain 30–35 psi in pneumatic drive wheels.
- Plan your trip in advance to avoid inclines if possible.
- Limit baggage weight to essential items.
- Try to maintain an even speed and avoid stop-and-go driving.

## What type of battery should I use?

We recommend deep-cycle batteries that are sealed and maintenance free. Both sealed lead-acid (SLA) and gel cell are deep-cycle batteries that are similar in performance.

Use these specifications to reorder deep-cycle batteries:

Battery Specifications	
Type:	Deep-cycle sealed lead-acid or gel cell
Size:	Group 24
Voltage:	12 volts each
Amperage:	70 or 80 amp hours
Size:	NF-22 (power seat option only)
Voltage:	12 volts each
Amperage:	45 - 55 amp hours

## Why do my new batteries seem weak?

Deep-cycle batteries employ a much different chemical technology than that used in car batteries, nickel-cadmium batteries (nicads), or in other common battery types. Deep-cycle batteries are specifically designed to provide power, drain down their charge, and then accept a relatively quick recharge. Sealed lead-acid batteries should be charged as often as possible. They do not have a “memory” like nickel-cadmium batteries.

We work closely with our battery manufacturer to provide a battery that best suits your Jazzy’s specific demands. Fresh batteries arrive regularly at Pride and are promptly shipped with a full charge. During shipping, the batteries encounter temperature extremes that may influence initial performance. Heat robs the charge from the battery, and cold slows the power available and extends the time needed to recharge the battery (just as with a car battery). It might take a few days for the temperature of the battery to stabilize and adjust to its new ambient temperature. More importantly, it takes a few “charging cycles” (a partial drain—then a full recharge) to establish the critical chemical balance that is essential to the battery’s peak performance and long life. It is well worth it to take the time to break in your battery properly.

*NOTE: The useful life of a battery is quite often a reflection of the care it receives.*

# IX. BATTERIES AND CHARGING

## **How can I ensure maximum battery life?**

A fully charged, deep-cycle battery provides reliable performance and extended battery life. Keep your Jazzy's batteries fully charged whenever possible. Batteries that are regularly and deeply discharged, infrequently charged, or stored without a full charge may be permanently damaged, causing unreliable Jazzy operation and limited battery life.

## **How should I store my Jazzy and its batteries?**

If you do not use your Jazzy regularly, we recommend maintaining battery vitality by charging the batteries at least once a week.

If you do not plan on using your Jazzy for an extended period, fully charge the batteries prior to storage. Disconnect the battery harnesses and store the Jazzy in a warm, dry environment. Avoid temperature extremes, such as freezing and excessively hot conditions, and never attempt to charge a frozen battery. A cold or frozen battery should be warmed for several days prior to recharging.

*NOTE: If you are storing a Jazzy for an extended period of time, you may wish to block the unit up with several boards under the frame. This keeps the tires off the ground and prevents the possibility of flat spots developing in the tires.*

## **What about public transportation?**

If you intend to use public transportation while using your Jazzy, you must contact in advance the transportation provider to determine their specific requirements. See II. "Safety" for more details.

Sealed lead-acid and gel cell batteries are designed for application in wheelchairs and in other mobility vehicles. Generally, sealed lead-acid batteries are safe for all forms of transportation such as aircraft, buses, and trains. We suggest that you contact your transportation provider to determine specific requirements of transportation and packaging.

## **What about shipping?**

If you wish to use a freight company to ship your Jazzy to your final destination, repack your Jazzy in the original shipping container and ship the batteries in separate boxes.



**WARNING! Battery posts, terminals, and related accessories contain lead and lead compounds. Wash hands after handling.**

# X. CARE AND MAINTENANCE

## ROUTINE MAINTENANCE

Your Jazzy is a sophisticated powered wheelchair. Like any motorized vehicle, it requires routine maintenance checks. You can perform some of these checks, but others require assistance from an authorized Pride provider. Preventive maintenance is very important. If you follow the maintenance checks in this section as scheduled, you can help ensure that your Jazzy gives you years of trouble-free operation. If you have any doubt as to your Jazzy's care or operation, contact your authorized Pride provider.

Your Jazzy, like most electrical equipment, is susceptible to damage from the elements. Avoid damp areas of any kind.



**CAUTION!** Direct exposure to water or dampness could cause the wheelchair to malfunction electronically and mechanically. Water can cause electrical components to corrode and the chair's frame to rust.

### Should your Jazzy come in contact with water:

1. Dry your Jazzy as thoroughly as possible with a dry towel.
2. Allow your Jazzy to sit in a warm, dry place for 12 hours to allow unseen water to evaporate.
3. Check the joystick operation and the brakes before using your Jazzy again.
4. If any inconsistencies are found, take your Jazzy to an authorized Pride provider.

## TEMPERATURE

Some of the parts of your Jazzy are susceptible to extreme changes in temperature. Always keep your Jazzy between the temperatures of 18° F and 122° F.

- In extremely cold temperatures the batteries may freeze. The specific temperature at which they freeze depends on a number of factors, such as battery charge, usage, and composition of the batteries (e.g., sealed lead-acid or gel cell).
- Temperatures above 122° F may cause your Jazzy to operate at a reduced speed. This reduced speed is a safety feature built into the controller that helps prevent damage to the motor and other electrical components. See VIII. "Operation."

## GENERAL GUIDELINES

- Avoid knocking or bumping the controller, especially the joystick.
- Avoid prolonged exposure of your Jazzy to extreme conditions, such as heat, cold, or moisture.
- Keep the controller clean.
- Check all controller connectors on the utility tray to ensure that they are all tight and secured properly. Also check the charger harness connector.
- When the battery condition meter is completely lit, the batteries are fully charged, and the controller and the electrical system are OK.
- If one red bar on the battery condition meter is blinking slowly, the batteries are low and need to be charged, but the controller and the electrical system are OK.
- If the battery condition meter is blinking rapidly, the controller has detected a fault in either its own circuits or in your Jazzy's circuits. See VIII. "Operation."
- Make sure the drive tires are inflated to 30 – 35 psi. See figure 46.



**Figure 46. Check Tire Pressure**



# X. CARE AND MAINTENANCE



**WARNING! Overinflating tires can cause them to explode and can result in personal injury.**

**WARNING! Do not use high pressure hose.**

- Use a rubber conditioner on the tire sidewalls to help preserve them. Never use a rubber conditioner on the tread area of the tires; doing so may make the tires slippery and cause your Jazzy to skid.
- The body shroud has been sprayed with a clear sealant coating. You can apply a light coat of car wax to help it retain its high-gloss appearance.
- Check all electrical connections. Make sure they are tight and are not corroded. Batteries must sit flat within the battery well, with the battery terminals facing inward, toward each other. Refer to the frame decal for the correct wiring layout.
- All wheel bearings are prelubricated and sealed. They require no subsequent lubrication.

## DAILY CHECKS

- With the controller turned off, check the joystick. Make sure it is not bent or damaged and that it returns to the center when you release it. Check the rubber boot around the base of the joystick for damage. Visually inspect the boot. Do not handle or try to repair it. See your authorized Pride provider if there is a problem.
- Visually inspect the controller harnesses. Make sure that they are not frayed or cut or have any wires exposed. See your authorized Pride provider if there is a problem with any of these harnesses.

## WEEKLY CHECKS

- Disconnect and inspect the controller and the charger harnesses from the utility tray. Look for corrosion. Contact your authorized Pride provider if necessary.
- Ensure that all parts of the controller system are securely fastened to your Jazzy. Do not overtighten any screws.
- Check for proper tire inflation. There should be 30 – 35 psi in each tire. If a tire does not hold air, see an authorized Pride provider for replacement of the tube.
- Calibrate the joystick if a noticeable difference in performance is detected or if the joystick does not operate properly. You can do this for the Remote Plus, Pilot, and Europa controllers.
- Check the brakes. This test should be carried out on a level surface with at least three feet of clearance around your Jazzy.

### To check the brakes:

1. Turn on the controller and turn down the speed and response adjustment knob.
2. After one second, check the battery condition meter. Make sure that it remains on.
3. Slowly push the joystick forward until you hear the electric brakes click. Immediately release the joystick. You must be able to hear each electrical brake operating within a few seconds of joystick movement. Repeat this test three times, pushing the joystick backwards, then left, and then right.

# X. CARE AND MAINTENANCE

## To calibrate the joystick (Remote Plus only):

1. Position the joystick in the full reverse position and hold it there. Turn on the controller.
2. The battery condition meter lights up from one bar to ten bars, and then back to one bar. It does this twice, then blinks rapidly.
3. Turn off the controller.
4. Position the joystick in the full forward position and hold it there; then turn the controller on.
5. The battery condition meter lights up from one bar to ten bars, and then back to one bar. It does this twice, then blinks once, and then it blinks continuously.
6. Turn off the controller. Now the joystick and controller are set up to function properly together.

## MONTHLY CHECKS

- Check that the anti-tip wheels do not rub the ground when you are operate the Jazzy. Adjust them as necessary. See VI. “Comfort Adjustments.”
- Check for extreme wear on the anti-tip wheels. Replace them as necessary.
- Check for drive tire wear. See an authorized Pride provider for repair.
- Check the rear casters for wear. Replace them as necessary.
- Check the rear forks for damage or fluttering which indicates that they may need to be adjusted or have the bearings replaced. See an authorized Pride provider for repair.
- Keep your Jazzy clean and free of foreign material, such as mud, dirt, hair, food, drink, etc.

## YEARLY CHECKS

Take your Jazzy to an authorized Pride provider for yearly maintenance. This helps ensure that your Jazzy is functioning properly and helps prevent future complications.

## STORAGE

Your wheelchair should be stored in a dry place, free from temperature extremes. When storing, disconnect the batteries from the Jazzy. See IX. “Batteries and Charging.”



**WARNING!** If you fail to store the unit properly, the frame can rust and the electronics can be damaged.

## CLEANING INSTRUCTIONS



**CAUTION!** Never hose off your Jazzy or place it in direct contact with water. Your Jazzy has a painted, ABS plastic body shroud that allows it to be easily wiped clean with a damp cloth.

**CAUTION!** Never use any chemicals to clean a vinyl seat, as they may cause the seat to become slippery or dry out and crack. Use soapy water and dry the seat thoroughly.

## TIRES AND TUBES

If your Jazzy is equipped with pneumatic tires, you should check the air pressure at least once a week. This prolongs the life of your tires and helps ensure the perfect operation of your chair. If you have a flat tire, replace the tube. Replacement tires and tubes are readily available through the provider where you purchased your Jazzy.

# X. CARE AND MAINTENANCE



**WARNING!** Make sure the tire is completely deflated before attempting repair.

## Follow these easy steps for a quick and safe repair:

1. Completely deflate the tire if pneumatic.
2. Use a 3/4-in. socket wrench to remove the drive wheel nut from the center hub of the wheel. See figure 47.
3. Pull the wheel off of the axle.
4. Remove the bolts that hold the wheel halves together.
5. Remove the old tube and/or tire and replace it with a new tube and/or tire.
6. Reassemble the wheel.
7. Slide the wheel back onto the shaft.
8. Install the drive wheel bolt into the center hub and tighten.
9. Inflate the tire to 30 – 35 psi.

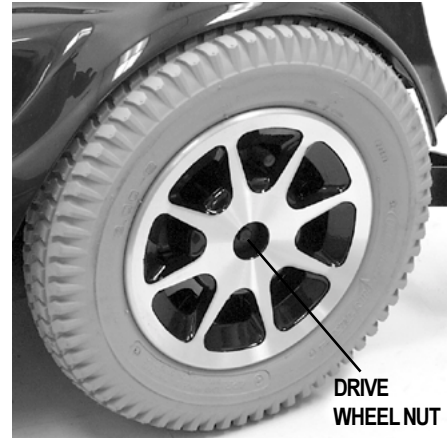

**Figure 47. Drive Wheel**

## BATTERY REPLACEMENT

### To replace the battery:

A diagram is printed on a decal on the Jazzy 1120<sub>2000</sub> frame near the battery tray. See figure 48.

1. Remove 5/16-in. detent pin from the bottom of the foot frame.
2. Lift the foot frame straight up.
3. Locate the two wiring harnesses that will be attached to your batteries.
4. Disconnect these two harnesses from their respective quick disconnects by pulling the quick disconnects toward you.
5. Remove batteries from the powerbase assembly.
6. Disconnect the battery harnesses from the positive and negative terminals.
7. Replace old batteries with new ones.

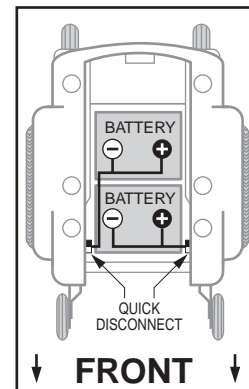

**Figure 48. Battery Connections**

*NOTE: It is easier to connect the harnesses to the batteries when you have the batteries away from your Jazzy. This gives you more room to work.*

8. Connect the wire labeled BAT (+) to a battery's positive (red) terminal. Connect the wire labeled BAT (-) to the negative (black) terminal. Install the battery in the rear of your Jazzy's battery tray with the battery's terminals facing inward, towards the center of the Jazzy. Plug the wiring harness into a quick disconnect.
9. Connect the wire labeled BAT (+) to the other battery's positive (red) terminal. Connect the wire labeled BAT (-) to the negative (black) terminal. Install the battery in the front of your Jazzy's battery tray with the battery's terminals facing inward, towards the center of the Jazzy. Plug the wiring harness into a quick disconnect.
10. Replace the foot frame using the 5/16-in. detent pin to secure.

*NOTE: It is important to be sure that your battery connections are tight and secure.*

# X. CARE AND MAINTENANCE

## MOTOR BRUSHES

The electric motors that power your Jazzy use carbon brushes. These brushes may become susceptible to wear over a long period of time. The motor brushes are the two contacts located inside the motor assembly that supply power to the motor. They are designed to provide several thousand hours of operation. However, if the brushes become dirty with carbon deposits or wear out, the motor will run poorly or not at all. We recommend that your authorized Pride provider inspect the brushes every six months or sooner if your Jazzy runs poorly. If inspection determines excessive wear on the brushes, they must be replaced or motor damage will result.

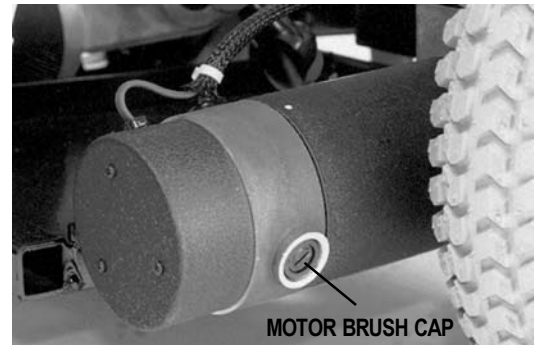

Figure 49. Motor

*NOTE: Failure to maintain the brushes could void your Jazzy's warranty.*

### To inspect or replace the motor brushes:

1. Remove the seat, body shroud, and batteries. See VII. "Disassembly."
2. Unscrew the motor brush caps. See figure 49.
3. Remove the brushes.
4. Inspect for wear. inspect for wear.
5. Replace brushes, if necessary. Contact your authorized Pride provider for replacement brushes.

## CORRECTIVE MAINTENANCE

If the battery indicator gauge does not light up when you turn on the power:

- Check the harness connections. Make sure they are tight.
- Check the circuit breaker. Reset it if necessary.
- Check the battery connections.

If the above conditions prove normal, you can load test the batteries with a battery load tester. These testers are available at automotive parts stores. Disconnect both batteries before load testing and follow the directions that come with the load tester. If either one of the batteries fails the load test, replace both of them. If your Jazzy still does not power up, contact your authorized Pride provider.

## WHEN TO SEE YOUR PRIDE PROVIDER FOR SERVICE

The following symptoms could indicate a serious problem with your Jazzy. If necessary, contact your authorized Pride provider. When calling, have the model number, serial number, nature of the problem, and the trouble code if available.

- Motor noise
- Frayed harnesses
- Cracked or broken connectors
- Uneven wear on any of the tires
- Jerky motion
- Pulling to one side
- Bent or broken wheel assemblies
- Does not power up
- Powers up, but does not move

# XI. OPTIONAL ACCESSORIES

The following accessories are available from your authorized Pride provider.

## **POSITIONING BELT**

The positioning belt (see figure 50) is designed to support the operator so that he or she does not slide down or forward in the seat. The positioning belt is not designed for use as a restraining device. Make sure the belt is secure but does not cause discomfort.

*NOTE: The positioning belt is not designed for use as a seat belt in a motor vehicle. Nor is your Jazzy suitable for use as a seat in any vehicle. Anyone traveling in a vehicle should be properly belted into seats approved by the auto manufacturer.*



**Figure 50. Positioning Belt**

## **OXYGEN TANK HOLDER**

The removable oxygen tank holder is mounted to the back of the seat by means of the accessory bracket. See figure 51.

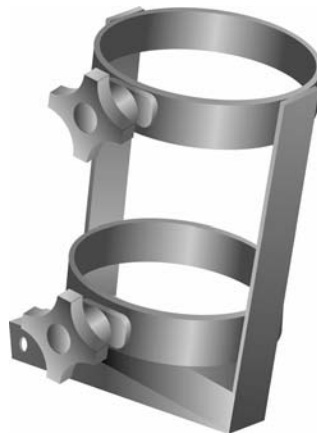

**Figure 51. Oxygen Tank Holder**

# XI. OPTIONAL ACCESSORIES

## CANE AND CRUTCH HOLDER

The removable cane and crutch holder is mounted to the back of the seat by means of the accessory bracket. See figure 52.

## WALKER HOLDER

The removable walker holder is mounted to the back of the seat by means of the accessory bracket. See figure 53. It can hold a standard size walker.

## REAR BASKET

The rear basket is mounted to the accessory bracket. See figure 54. It has a handle that you can use when you remove the basket from your Jazzy.

## CUP HOLDER (NOT SHOWN)

The cup holder is mounted to the armrest.



Figure 52. Cane and Crutch Holder



Figure 53. Walker Holder



Figure 54. Rear Basket

# XII. WARRANTY

## LIFETIME LIMITED WARRANTY

For the lifetime of your Jazzy, from the date of purchase, Pride will repair or replace at our option to the original purchaser, free of charge, any of the following parts found upon examination by an authorized representative of Pride to be defective in material and/or workmanship:

- Structural frame components

## TWO-YEAR WARRANTY

For two (2) years from the date of purchase, Pride will repair or replace at our option to the original purchaser, free of charge, any of the following parts found upon examination by an authorized representative of Pride to be defective in material and/or workmanship:

- Electronics

## EIGHTEEN-MONTH WARRANTY

For eighteen (18) months from the date of purchase, Pride will repair or replace at our option to the original purchaser, free of charge, any of the following parts found upon examination by an authorized representative of Pride to be defective in material and/or workmanship:

- Motor/gearbox assembly

## WARRANTY EXCEPTIONS

**Motor:** If damage occurs to the commutator of a motor as a result of not replacing the motor brushes after heavy wear to brushes. Motor brushes are wear items and are not warranted.

**Brake:** One-year warranty for electrical function of the brake. Brake pads are a wear item and are not warranted.

## SIX-MONTH LIMITED WARRANTY

For six (6) months from the date of purchase, Pride will repair or replace at our option to the original purchaser, free of charge, any of the following parts found upon examination by an authorized representative of Pride to be defective in material and/or workmanship:

- Plastic components, except body
- Rubber components (except tires and tubes)
- Bearings and bushings
- Casters and anti-tip wheels

Battery warranty is covered by the battery manufacturer. Battery warranty is not covered by Pride.



## XII. WARRANTY

Warranty service can be performed by an authorized Pride provider or by Pride. Do not return faulty parts to Pride without prior consent. All transportation costs and shipping damage incurred while submitting parts for repair or replacement are the responsibility of the original purchaser.

### WARRANTY EXCLUSIONS

- ABS plastic body shrouds and footrest covers are wear items and are not warranted
- Batteries (battery manufacturer provides a six-month limited warranty)
- Tires and tubes
- Upholstery and seating
- Repairs and/or modifications made to any part without specific prior written consent from Pride
- Circumstances beyond the control of Pride
- Labor, service calls, shipping, and other charges incurred for repair of the product unless specifically authorized by Pride

#### Damage caused by:

- Battery fluid spillage or leakage
- Abuse, misuse, accident, or negligence
- Improper operation, maintenance, or storage
- Commercial use, or use other than normal

There is no other express warranty.

Implied warranties, including those of merchantability and fitness for a particular purpose, are limited to one (1) year from the date of purchase and to the extent permitted by law. Any and all implied warranties are excluded. This is the exclusive remedy. Liabilities for consequential damages under any and all warranties are excluded.

Some states do not allow limitations on how long an implied warranty lasts or do not allow the exclusion of limitation of incidental or consequential damages. The above limitation or exclusion may not apply to you.

This warranty gives you specific rights, and you may also have other rights which vary from state to state.

Please fill out and return the warranty card to Pride. This aids Pride in providing the best possible technical and customer service.



**Pride**  
*Mobility Products Corp.*

**182 Susquehanna Ave.  
Exeter, PA 18643**

**1-800-800-8586**

**[www.pridemobility.com](http://www.pridemobility.com)**