

Celebrity DX Sport

The Ultimate in Style & Performance®



OWNER'S MANUAL

Pride

Mobility Products Australia Pty. Ltd.
www.pridemobility.com

21 Healey Road Dandenong, 3175 Victoria, Australia ACN # 088 609 661

SAFETY GUIDELINES

The symbols below are used throughout this owner's manual and on the scooter to identify warnings and important information. It is very important for you to read them and understand them completely.



WARNING! Indicates a potentially hazardous condition/situation. Failure to follow designated procedures can cause either personal injury, component damage, or malfunction. On the product, this icon is represented as a black symbol on a yellow triangle with a black border.



MANDATORY! These actions should be performed as specified. Failure to perform mandatory actions can cause personal injury and/or equipment damage. On the product, this icon is represented as a white symbol on a blue dot with a white border.



PROHIBITED! These actions are prohibited. These actions should not be performed at any time or in any circumstances. Performing a prohibited action can cause personal injury and/or equipment damage. On the product, this icon is represented as a black symbol with a red circle and red slash.

Please fill out the following information for quick reference:

Pride Provider: _____	
Address: _____	
Phone Number: _____	
Purchase Date: _____	Serial Number: _____

NOTE: This owner's manual is compiled from the latest specifications and product information available at the time of publication. We reserve the right to make changes as they become necessary. Any changes to our products may cause slight variations between the illustrations and explanations in this manual and the product you have purchased.

This product is manufactured by:
Pride Mobility Products Corporation
182 Susquehanna Avenue
Exeter, PA 18643-2694
USA

Copyright © 2007
Pride Mobility Products Australia Pty. Ltd.

INFMANU3477/Rev A/January 2007



CONTENTS

I. INTRODUCTION.....	4
II. SAFETY	5
III. SPECIFICATIONS	16
IV. YOUR SCOOTER	18
V. BATTERIES AND CHARGING	23
VI. OPERATION	28
VII. COMFORT ADJUSTMENTS.....	30
VIII. DISASSEMBLY AND ASSEMBLY	33
IX. BASIC TROUBLESHOOTING	36
X. CARE AND MAINTENANCE	38
XI. WARRANTY.....	41

I. INTRODUCTION

SAFETY

Welcome to Pride Mobility Products Australia Pty. Ltd. (Pride). The product you have purchased combines state-of-the-art components with **safety**, comfort, and styling in mind. We are confident the design features will provide you with the conveniences you expect during your daily activities. Understanding how to **safely** operate and care for this product should bring you years of trouble free operations and service.

Read and follow all instructions, warnings, and notes in this manual and all other accompanying literature before attempting to operate this product for the first time. In addition, your **safety** depends upon you, as well as your provider, carer, or healthcare professional in using good judgement.

If there is any information in this manual which you do not understand, or if you require additional assistance for setup or operation, please contact your authorised Pride Provider. **Failure to follow the instructions, warnings, and notes in this manual and those located on your Pride product can result in personal injury or product damage and will void Pride's product warranty.**

PURCHASER'S AGREEMENT

By accepting delivery of this product, you promise that you will not change, alter, or modify this product or remove or render inoperable or unsafe any guards, shields, or other safety features of this product; fail, refuse, or neglect to install any retrofit kits from time to time provided by Pride to enhance or preserve the safe use of this product.

INFORMATION EXCHANGE

We want to hear your questions, comments, and suggestions about this manual. We would also like to hear about the safety and reliability of your new scooter, and about the service you received from your authorised Pride Provider. Please notify us of any change of address, so we can keep you apprised of important information about safety, new products, and new options that can increase your ability to use and enjoy your scooter. Please feel free to contact us at the address below:

Pride Mobility Products Australia Pty. Ltd.
21 Healey Road
Dandenong, 3175
Victoria, Australia

NOTE: If you ever lose or misplace your product registration card or your copy of this manual, contact us and we will be glad to send you a new one immediately.

II. SAFETY

PRODUCT SAFETY SYMBOLS

The symbols below are used on the scooter to identify warnings, mandatory actions, and prohibited actions. It is very important for you to read and understand them completely.



Pinch/Crush points created during assembly.



Corrosive chemicals contained in battery. Use only AGM or Gel-Cell batteries to reduce the risk of leakage or explosive conditions.



EMI-RFI- This product has been tested and passed at an immunity level of 20 V/m.



Read and follow the information in the owner's manual.



Maximum seating weight.



Unlocked and in freewheel mode.

Place unit on level ground and stand behind or to one side when changing from drive mode to freewheel mode or freewheel mode to drive mode.

Locked and in drive mode.

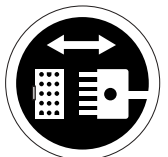

Front-to-rear plug orientation.

II. SAFETY



Use only AGM or Gel-Cell batteries.



Do not remove anti-tip wheels.



Do not use a cell phone, walkie/talkie, laptop, or other radio transmitter while operating.



Avoid exposure to rain, snow, ice, salt, or standing water whenever possible. Maintain and store in a clean and dry condition.



Removal of grounding prong can create electrical hazard. If necessary, properly install an approved 3-pronged adapter to an electrical outlet having 2-pronged plug access.

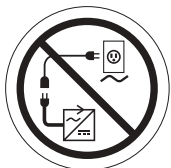

Do not connect an extension lead to the AC/DC converter or the battery charger.

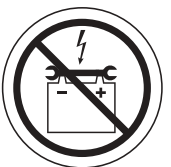

Contact with tools can cause electrical shock.



Keep your hands away from the tyres when driving. Be aware that loose fitting clothing can become caught in the drive tyres.



Disposal and recycling-Contact your authorised Pride Provider for information on proper disposal of your Pride product and its packaging.

II. SAFETY

GENERAL



MANDATORY! Do not operate your new scooter for the first time without completely reading and understanding this owner's manual.

Your scooter is a state-of-the-art life-enhancement device designed to increase mobility. Pride provides an extensive variety of products to best fit the individual needs of the scooter user. Please be aware that the final selection and purchasing decision regarding the type of scooter to be used is the responsibility of the scooter user who is capable of making such a decision and his/her healthcare professional (i.e., medical doctor, physical therapist, etc.).

The contents of this manual are based on the expectation that a mobility device expert has properly fitted the scooter to the user and has assisted the prescribing healthcare professional and/or the authorised Pride Provider in the instruction process for the use of the product.

There are certain situations, including some medical conditions, where the scooter user will need to practice operating the scooter in the presence of a trained attendant. A trained attendant can be defined as a family member or care professional specially trained in assisting a scooter user in various daily living activities.

As you begin using your scooter during daily activities, you will probably encounter situations in which you will need some practice. Simply take your time and you will soon be in full and confident control as you manoeuvre through doorways, on and off lifts, up and down ramps, and over moderate terrain.

Below are some precautions, tips, and other safety considerations that will help you become accustomed to operating the scooter safely.

MODIFICATIONS

Pride has designed and engineered your scooter to provide maximum mobility and utility. However, under no circumstances should you modify, add, remove, or disable any feature, part, or function of your scooter.



WARNING! Do not modify your scooter in any way not authorised by Pride. Unauthorised modifications will void the product warranty.

REMOVABLE PARTS



WARNING! Do not attempt to lift or move your scooter by any of its removable parts, including the armrests, seat, or shroud.

II. SAFETY

PRE-RIDE SAFETY CHECK

Get to know the feel of your scooter and its capabilities. Pride recommends that you perform a safety check before each use to make sure your scooter operates smoothly and safely.

Perform the following inspections prior to using your scooter:

- Check for proper tyre inflation (if equipped with pneumatic tyres).
- Check all electrical connections. Make sure they are tight and not corroded.
- Check all harness connections. Make sure they are secured properly.
- Check the brakes.
- Check battery charge.

If you discover a problem, contact your authorised Pride Provider for assistance.

TYRE INFLATION

If your scooter is equipped with pneumatic tyres, you should check or have the air pressure checked at least once a week. Proper inflation pressures will prolong the life of your tyres and help ensure the smooth operation of your scooter.



WARNING! It is critically important that 2-2.4 bar (30-35 psi) tyre pressure be maintained in pneumatic tyres at all times. Do not underinflate or overinflate your tyres. Low pressure may result in loss of control and overinflated tyres may burst. Failure to maintain 2-2.4 bar (30-35 psi) tyre pressure in pneumatic tyres at all times may result in tyre and/or wheel failure.

WARNING! Inflate your scooter tyres from a regulated air source with an available pressure gauge. Inflating your tyres from an unregulated air source could overinflate them, resulting in a burst tyre.

WEIGHT LIMITATIONS

Your scooter is rated for a maximum weight capacity. Refer to the specifications table for information.



WARNING! Stay within the specified weight capacity of your scooter. Exceeding the weight capacity voids your warranty. Pride will not be held responsible for injuries and/or property damage resulting from failure to observe weight limitations.

WARNING! Do not carry passengers on your scooter. Carrying passengers on your scooter may affect the centre of gravity, resulting in a tip or fall.

INCLINE INFORMATION

More and more buildings have ramps with specified degrees of inclination, designed for easy and safe access. Some ramps may have turning switchbacks (180-degree turns) that require you to have good cornering skills on your scooter.

- Proceed with extreme caution as you approach the downgrade of a ramp or other incline.
- Take wide swings with your scooter around any tight corners. If you do that, the scooter's rear wheels will follow a wide arc, not cut the corner short, and not bump into or get hung up on any railing corners.
- When driving down a ramp, keep the scooter's speed adjustment set to the slowest speed setting to ensure a safely controlled descent.
- Avoid sudden stops and starts.

II. SAFETY

When climbing an incline, try to keep your scooter moving. If you must stop, start up again slowly and then accelerate cautiously. When driving down an incline, do so by setting the speed adjustment dial to the slowest setting and driving in the forward direction only. If your scooter starts to move down the incline faster than you anticipated or desired, allow it to come to a complete stop by releasing the throttle control lever. Then push the throttle control lever forward slightly to ensure a safely controlled descent.

WARNING! When climbing an incline, do not zigzag or drive at an angle up the face of the incline. Drive your scooter straight up the incline. This greatly reduces the possibility of a tip or a fall. Always exercise extreme caution when negotiating an incline.

WARNING! Do not drive your scooter across the side of an incline or diagonally up or down an incline; do not stop, if possible, while driving up or down an incline.



WARNING! You should not travel up or down a potentially hazardous incline (i.e., areas covered with snow, ice, cut grass, or wet leaves).

WARNING! When on any sort of an incline or decline, never place the scooter in freewheel mode while seated on it or standing next to it.

WARNING! Even though your scooter is capable of climbing slopes greater than those illustrated in **figure 1**, do not, under any circumstances, exceed the incline guidelines or any other specifications presented in this manual. Doing so could cause instability in your scooter.

Handicap public access ramps are not subject to government regulation in all countries and therefore do not necessarily share the same standard percent of slope. Other inclines may be natural or, if man-made, not designed specifically for scooters. **Figure 1** illustrates your scooter's stability and its ability to climb grades under various weight loads and under controlled testing conditions.

These tests were conducted with the scooter's seat in the highest position and adjusted rearward on the seat base to its farthest rearward position. Use this information as a guideline. Your scooter's ability to travel up inclines is affected by your weight, your scooter's speed, your angle of approach to the incline, and your scooter setup.

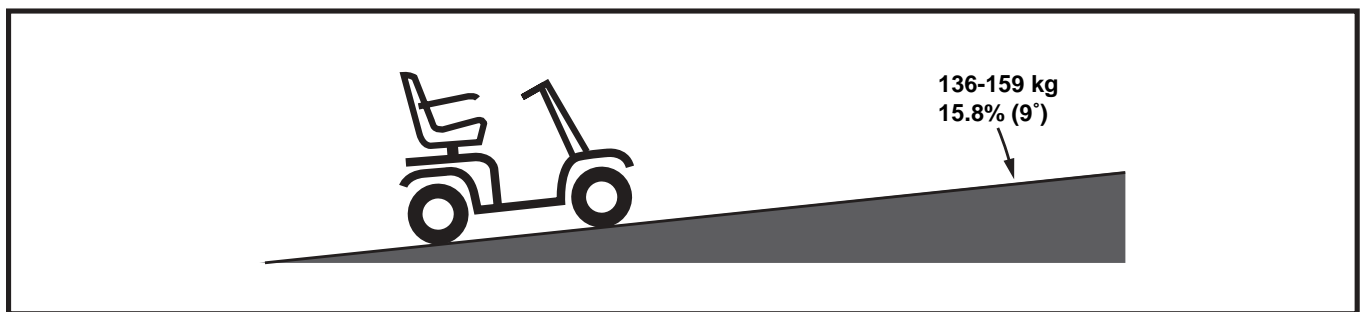

Figure 1. Maximum Recommended Incline Angle



WARNING! Any attempt to climb or descend a slope steeper than what is shown in **figure 1** may put your scooter in an unstable position and cause it to tip.

WARNING! Never carry an oxygen tank weighing more than 6 kg. Never fill the front or rear basket with contents exceeding 6 kg.

II. SAFETY

When you approach an incline, it is best to lean forward. See figures 2 and 2A. This shifts the centre of gravity of you and your scooter toward the front of the scooter for improved stability.

NOTE: When negotiating ramps, if the throttle control lever is released while moving forward, the powered scooter may "rollback" approximately 30.5 cm before the brake engages. If the throttle control lever is released while moving in reverse, the powered scooter may "rollback" approximately one metre before the brake engages.

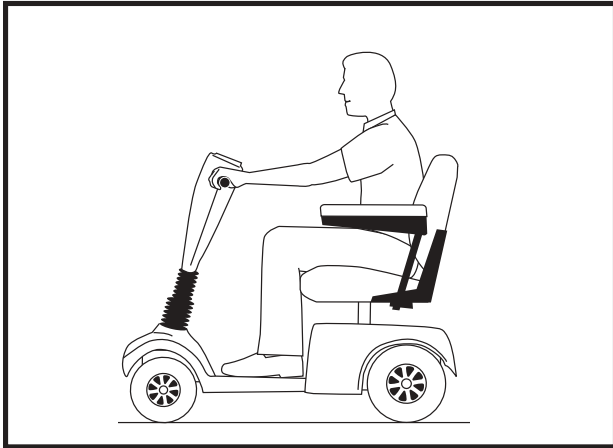

Figure 2. Normal Driving Position

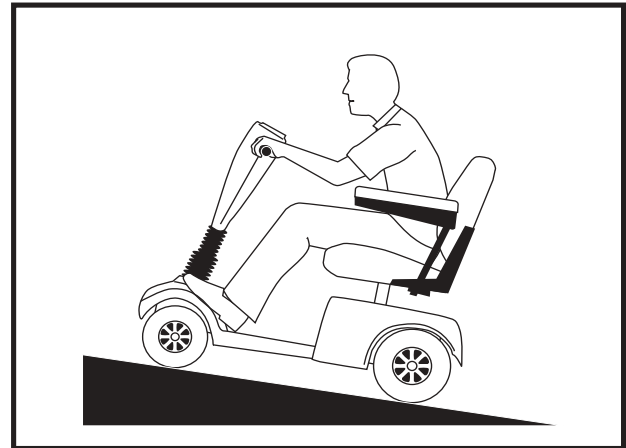

Figure 2A. Increased Stability Driving Position

CORNERING INFORMATION

Excessively high cornering speeds can create the possibility of tipping. Factors which affect the possibility of tipping include, but are not limited to, cornering speed, steering angle (how sharply you are turning), uneven road surfaces, inclined road surfaces, riding from an area of low traction to an area of high traction (such as passing from a grassy area to a paved area – especially at high speed while turning), and abrupt directional changes. High cornering speeds are not recommended. If you feel that you may tip over in a corner, reduce your speed and steering angle (i.e., lessen the sharpness of the turn) to prevent your scooter from tipping.



WARNING! When cornering sharply, reduce your speed and maintain a centre of gravity. When using your scooter at higher speeds, do not corner sharply. This greatly reduces the possibility of a tip or fall. Always exercise common sense when cornering.

BRAKING INFORMATION

Your scooter is equipped with these powerful brake systems:

- **Regenerative:** Uses electricity to rapidly slow the vehicle when the throttle control lever returns to the centre/stop position.
- **Disc Park Brake:** Activates mechanically after regenerative braking slows the vehicle to near stop or when power is removed from the system for any reason.

II. SAFETY

OUTDOOR DRIVING SURFACES

Your scooter is designed to provide optimum stability under normal driving conditions—dry, level surfaces composed of concrete or tarmac. However, Pride recognises that there will be times when you will encounter other surface types. For this reason, your scooter is designed to perform admirably on packed soil, grass, and gravel. Feel free to use your scooter safely on lawns and in park areas.

- Reduce your scooter's speed when driving on uneven terrain and/or soft surfaces.
- Avoid tall grass that can become tangled in the running gear.
- Avoid loosely packed gravel and sand.
- If you feel unsure about a driving surface, avoid that surface.

PUBLIC STREETS AND ROADWAYS



WARNING! Exercise extreme caution when operating the scooter on footpaths, pavements, bridleways, pedestrian, areas and roads.

STATIONARY OBSTACLES (STEPS, KERBS, ETC.)

WARNING! Do not drive near raised surfaces, unprotected ledges and/or drop-offs (kerbs, porches, stairs, etc.).

WARNING! Do not attempt to have your scooter climb or descend an obstacle that is inordinately high.



WARNING! Do not attempt to have your scooter proceed rearward down any step, kerb, or other obstacle. This may cause the scooter to tip.

WARNING! Be sure your scooter is traveling perpendicular to any kerb you may be required to ascend or descend. **See figures 3 and 3A.**

WARNING! Do not attempt to negotiate a kerb that has a height greater than 5 cm.

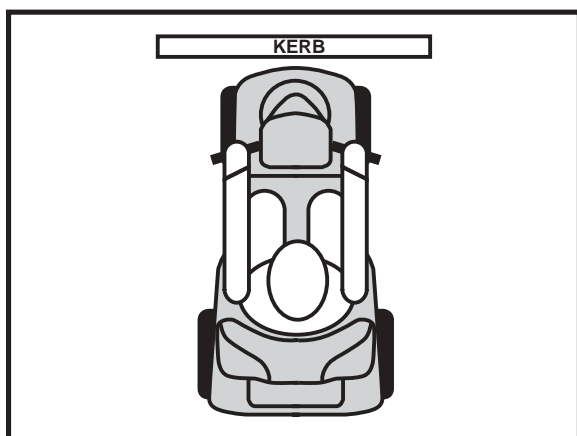

Figure 3. Correct Kerb Approach

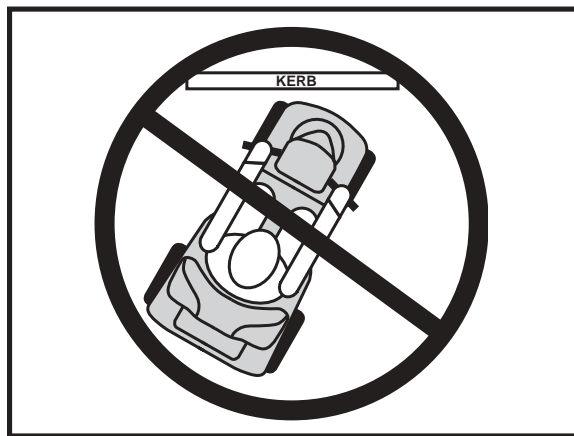

Figure 3A. Incorrect Kerb Approach

II. SAFETY

INCLEMENT WEATHER PRECAUTIONS

Exposure of your scooter to inclement weather conditions should be avoided whenever possible. If suddenly caught up in rain, snow, severe cold or heat while operating your scooter, proceed to shelter at the earliest opportunity. Thoroughly dry your scooter before storing, charging, or operating your scooter.

WARNING! Operating in rain, snow, salt, mist/spray conditions, and on icy/slippery surfaces can cause damage to the scooter and electrical system. Maintain and store your scooter in a dry and clean condition.



WARNING! Prolonged exposure to hot or cold conditions may affect the temperature of upholstered and non-upholstered items on the scooter, possibly resulting in skin irritation. Exercise caution when using your scooter in extremely hot or cold conditions or when exposing your scooter to direct sunlight for prolonged periods of time.

FREEWHEEL MODE

Your scooter is equipped with a manual freewheel lever that, when engaged, allows the scooter to be pushed. For more information about how to place your scooter into and out of freewheel mode, see IV. “Your Scooter.”

WARNING! When your scooter is in freewheel mode, the braking system is disengaged.



- Disengage the drive motors only on a level surface.
- Ensure the key is removed from the key switch.
- Stand behind the scooter to engage or disengage freewheel mode. Never sit on a scooter to do this.
- After you have finished pushing your scooter, always return it to the drive mode to lock the brakes.

An added feature built into the scooter is “**push-too-fast**” protection which safeguards the scooter against gaining excessive speed while in freewheel mode.

“Push-too-fast” operates differently depending on which of two conditions exists:

- If the key is switched “off” while in freewheel mode, the scooter’s controller activates regenerative braking when the scooter is pushed faster than a maximum threshold which has been preprogrammed. In this case, the controller is acting as a speed governor.
- If the key is switched “on” while in freewheel mode, you will encounter considerable resistance at any speed. This prevents the scooter from gaining unwanted momentum should the manual freewheel lever inadvertently be released while driving the scooter.

STAIRS AND ESCALATORS

Scooters are not designed to travel up or down stairs or escalators. Always use a lift.



WARNING! Do not use your scooter to negotiate steps or escalators.

DOORS

- Determine if the door opens toward or away from you.
- Use your hand to turn the knob or push the handle or push-bar.
- Drive your scooter gently and slowly forward to push the door open. Or drive your scooter gently and slowly rearwards to pull the door open.

II. SAFETY

LIFTS

Modern lifts have a door edge safety mechanism that, when pushed, reopens the door(s).

- If you are in the doorway of a lift when the door(s) begin to close, push on the rubber door edge or allow the rubber door edge to contact the scooter and the door will reopen.
- Use care that handbags, packages, or scooter accessories do not become caught in lift doors.

NOTE: *If your scooter's turning radius is greater than 1500 mm, it may be difficult to manoeuvre in lifts and building entrances. Use caution when attempting to turn or manoeuvre your scooter in small spaces and avoid areas that might pose a problem.*

LIFT/ELEVATION PRODUCTS

If you will be traveling with your scooter, you may find it necessary to use a lift/elevation product to aid in transportation. Pride recommends that you closely review the instructions, specifications, and safety information set forth by the manufacturer of the lift/elevation product before using that product.



WARNING! Never sit on your scooter when it is being used in connection with any type of lift/elevation product. Your scooter was not designed with such use in mind and any damage or injury incurred from such use is not the responsibility of Pride.

BATTERIES

In addition to following the warnings below, be sure to comply with all other battery handling information.

WARNING! Scooter batteries are heavy (refer to specifications table). Do not lift weight beyond your capacity. If necessary, get someone physically able to lift the scooter batteries for you.



WARNING! Battery posts, terminals, and related accessories contain lead and lead compounds. Wash hands after handling.

WARNING! Always protect the batteries from freezing and never charge a frozen battery..

WARNING! Connect the battery harnesses in the proper manner. RED (+) cables must be connected to positive (+) battery terminals/posts. BLACK (-) cables must be connected to negative (-) battery terminals/posts. REPLACE cables immediately if damaged. Protective caps must be installed over all battery terminals.

BATTERY DISPOSAL AND RECYCLING

If you encounter a damaged or cracked battery, immediately enclose it in a plastic bag and call your authorised Pride Provider for instructions on disposal. Your authorised Pride Provider will also have the necessary information on battery recycling, which is our recommended course of action.

PREVENTING UNINTENDED MOVEMENT



WARNING! If you anticipate being seated in a stationary position for an extended period of time, turn off the power. This will prevent unexpected motion from inadvertent throttle control lever contact.

II. SAFETY

MOTOR VEHICLE TRANSPORT

Pride recommends that you do not remain seated in your scooter while traveling in a motor vehicle. The scooter should be stowed in the boot of a car or in the back of a truck or van with the batteries removed and properly secured.

WARNING! Although your scooter may be equipped with a positioning belt, this belt is not designed to provide restraint during motor vehicle transport. Anyone travelling in a motor vehicle should be properly secured in the motor vehicle seat with safety belts fastened securely.



WARNING! Do not sit on your scooter while it is in a moving vehicle.

WARNING! Always be sure your scooter and its batteries are properly secured when it is being transported. Batteries should be secured in an upright position, and protective caps should be installed on the battery terminals. Batteries should not be transported with any flammable or combustible items.

GETTING ONTO AND OFF YOUR SCOOTER

Getting onto and off of your scooter requires a good sense of balance. Please observe the following safety tips when getting onto and off your scooter:

- Remove the key from the key switch.
- Ensure that your scooter is not in freewheel mode. See IV. “Your Scooter.”
- Make certain that the seat is secured into place.
- Pivot the armrests up to make getting onto and off of the scooter easier.

WARNING! Position yourself as far back as possible in the scooter seat to prevent the scooter from tipping.



WARNING! Avoid putting all of your weight on the scooter armrests and do not use the armrests for weight bearing purposes, such as transfers. Such use may cause the scooter to tip, resulting in a fall from the scooter.

WARNING! Avoid putting all of your weight on the floorboard. Such use may cause the scooter to tip.

REACHING AND BENDING

Avoid reaching or bending while driving your scooter. Bending forward creates the risk of accidental throttle control lever contact. Bending to the side while seated creates the risk of tipping. It is important to maintain a stable centre of gravity and keep the scooter from tipping. Pride recommends that the scooter user determine his/her personal limitations and practice bending and reaching in the presence of a qualified attendant.



WARNING! Do not bend, lean, or reach for objects if you have to pick them up from the scooter deck or from either side of the scooter. Movements such as these may change your centre of gravity and the weight distribution of the scooter and cause your scooter to tip.

WARNING! Keep your hands away from the tyres when driving. Be aware that loose fitting clothing can become caught in drive tyres.

POSITIONING BELTS

Your authorised Pride Provider, therapist(s), and other healthcare professionals are responsible for determining your requirement for a positioning belt in order to operate your scooter safely.



WARNING! If you require a positioning belt to safely operate your scooter, make sure it is fastened securely.

II. SAFETY

PRESCRIPTION DRUGS/PHYSICAL LIMITATIONS

The scooter user must exercise care and common sense when operating his/her scooter. This includes awareness of safety issues when taking prescribed or over-the-counter drugs or when the user has specific physical limitations.



WARNING! Consult your physician if you are taking prescribed or over-the-counter medication or if you have certain physical limitations. Some medications and limitations may impair your ability to operate your scooter in a safe manner.

ALCOHOL/SMOKING

The scooter user must exercise care and common sense when operating his/her scooter. This includes awareness of safety issues while under the influence of alcohol or while smoking.

WARNING! Do not operate your scooter while you are under the influence of alcohol, as this may impair your ability to drive safely.



WARNING! Although the scooter seat has passed the necessary testing requirements for cigarette smoke, Pride recommends that you adhere to the following safety guidelines:

- Do not leave lit cigarettes unattended.
- Keep ashtrays a safe distance from the seat cushions.
- Always make sure cigarettes are completely extinguished before disposal.

ELECTROMAGNETIC AND RADIO FREQUENCY INTERFERENCE (EMI/RFI)



WARNING! Laboratory tests have shown that electromagnetic and radio frequency waves can have an adverse affect on the performance of electrically-powered mobility vehicles.

Electromagnetic and Radio Frequency Interference can come from sources such as cellular phones, mobile two-way radios (such as walkie-talkies), radio stations, TV stations, amateur radio (HAM) transmitters, wireless computer links, microwave signals, paging transmitters, and medium-range mobile transceivers used by emergency vehicles. In some cases, these waves can cause unintended movement or damage to the control system. Every electrically-powered mobility vehicle has an immunity (or resistance) to EMI. The higher the immunity level, the greater the protection against EMI. This product has been tested and has passed at an immunity level of 20 V/M.

WARNING! Be aware that cell phones, two-way radios, laptops, and other types of radio transmitters may cause unintended movement of your electrically-powered mobility vehicle due to EMI. Exercise caution when using any of these items while operating your mobility vehicle and avoid coming into close proximity of radio and TV stations.



WARNING! The addition of accessories or components to the electrically-powered mobility vehicle can increase the susceptibility of the vehicle to EMI. Do not modify your scooter in any way not authorised by Pride.

WARNING! The electrically-powered mobility vehicle itself can disturb the performance of other electrical devices located nearby, such as alarm systems.

NOTE: For further information on EMI/RFI, visit the Resource Center on www.pridemobility.com. If unintended motion or brake release occurs, turn your scooter off as soon as it is safe to do so. Contact your authorised Pride Provider to report the incident.

III. SPECIFICATIONS

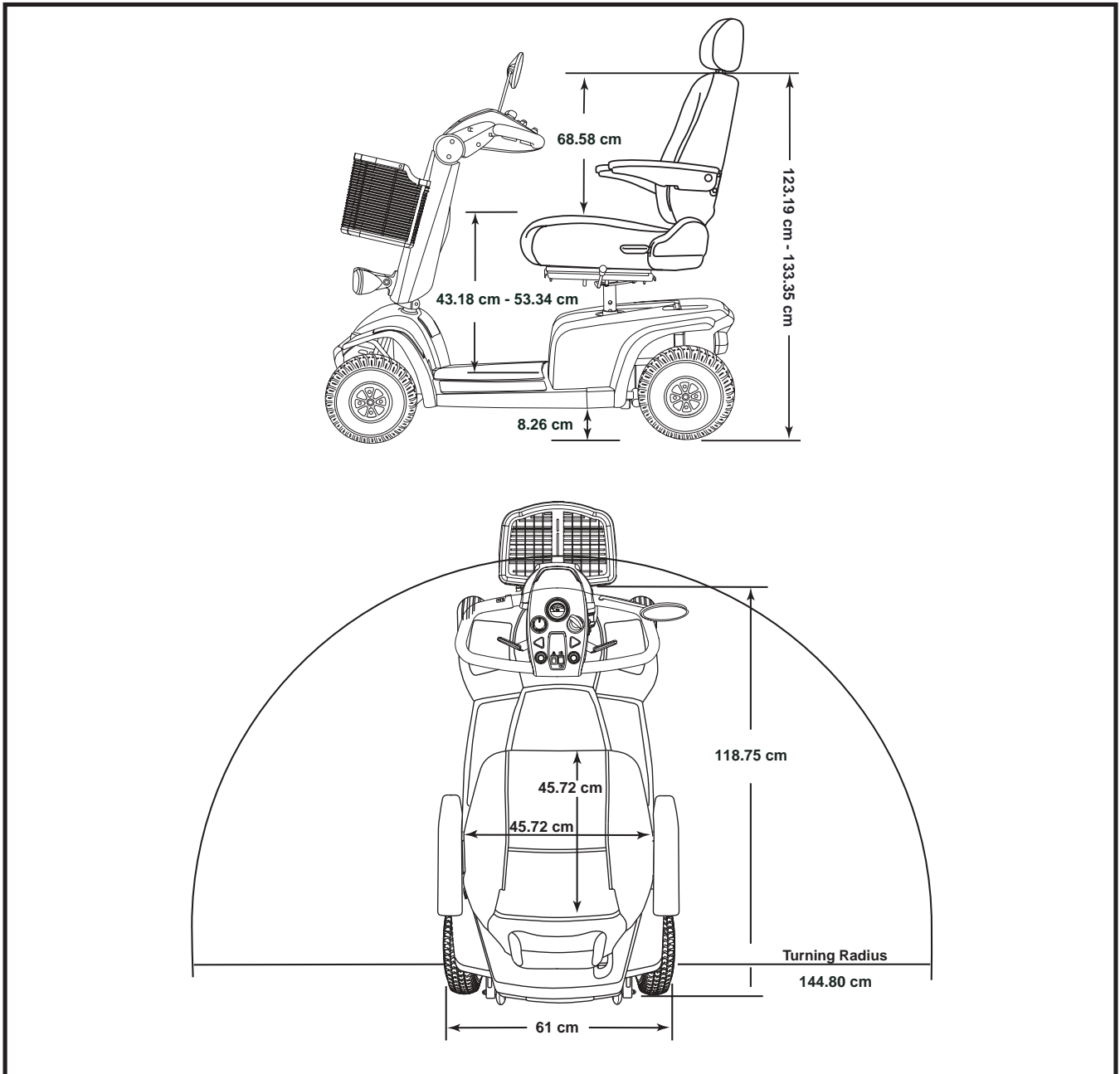

Figure 4. Scooter Dimensions

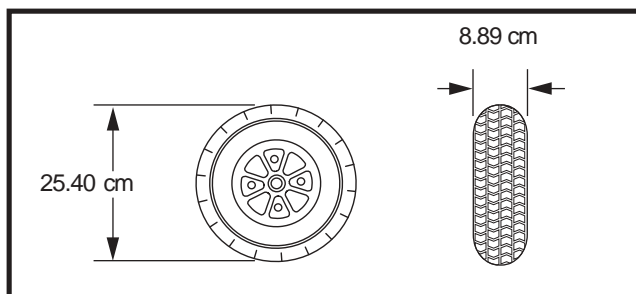

Figure 4A. Front Tyre Dimensions

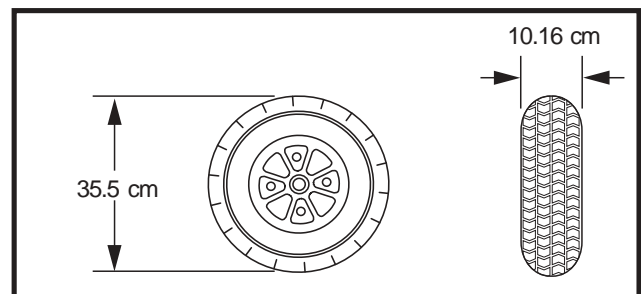

Figure 4B. Rear Tyre Dimensions

III. SPECIFICATIONS

Model Numbers	SC4401DXSPAUS
Class Of Use	B
Maximum Safe Slope	See figure 1.
Maximum Climbing Ability	See figure 1.
Maximum Obstacle Climbing Ability	5 cm
Overall Length²	118.75 cm
Overall Width²	61 cm
Total Weight	87.54 kg
Total Weight Without Batteries	65.31 kg
Heaviest Piece When Disassembled	Front section: 29.02 kg
Turning Radius²	144.80 cm
Speed (Maximum)¹	Variable up to 12.87 km/h
Range Per Charge¹	Up to 40.23 km
Ground Clearance²	8.26 cm
Weight Capacity	159 kg maximum
Standard Seating	Type: CRS Deluxe Weight: 16.78 kg Material: Vinyl Dimensions: 45.72 cm width 45.72 cm depth 68.58 cm height
Drive System	Rear-wheel drive, sealed transaxle, 24-volt DC motor
Dual Braking System	Electronic, regenerative and electromechanical
Tyres	Type: pneumatic: Front: 8.89 cm x 25.40 cm Rear: 10.16 cm x 35.5 cm
Battery Requirements	Two 12-volt, deep-cycle (AGM or Gel-Cell type recommended) Size: 40 AH Weight: 11.11 kg each
Battery Charger	Off-board

(1) Varies with user weight, terrain type, battery amp-hour (AH), battery charge, battery condition, and tyre condition.

(2) Due to manufacturing tolerances and continual product improvement, this specification can be subject to a variance of (+ or -) 3 %.

NOTE: All specifications subject to change without notice.

IV. YOUR SCOOTER

TILLER CONSOLE

The tiller console houses all of the controls needed to drive your scooter, including the speed adjustment dial, throttle control lever, battery condition meter, turn indicator buttons, lights switch, hazard lights switch, and horn buttons. **See figure 5.**



WARNING! Do not expose the tiller console to moisture. In the event that the tiller console does become exposed to moisture, do not attempt to operate your scooter until the tiller console has dried thoroughly.

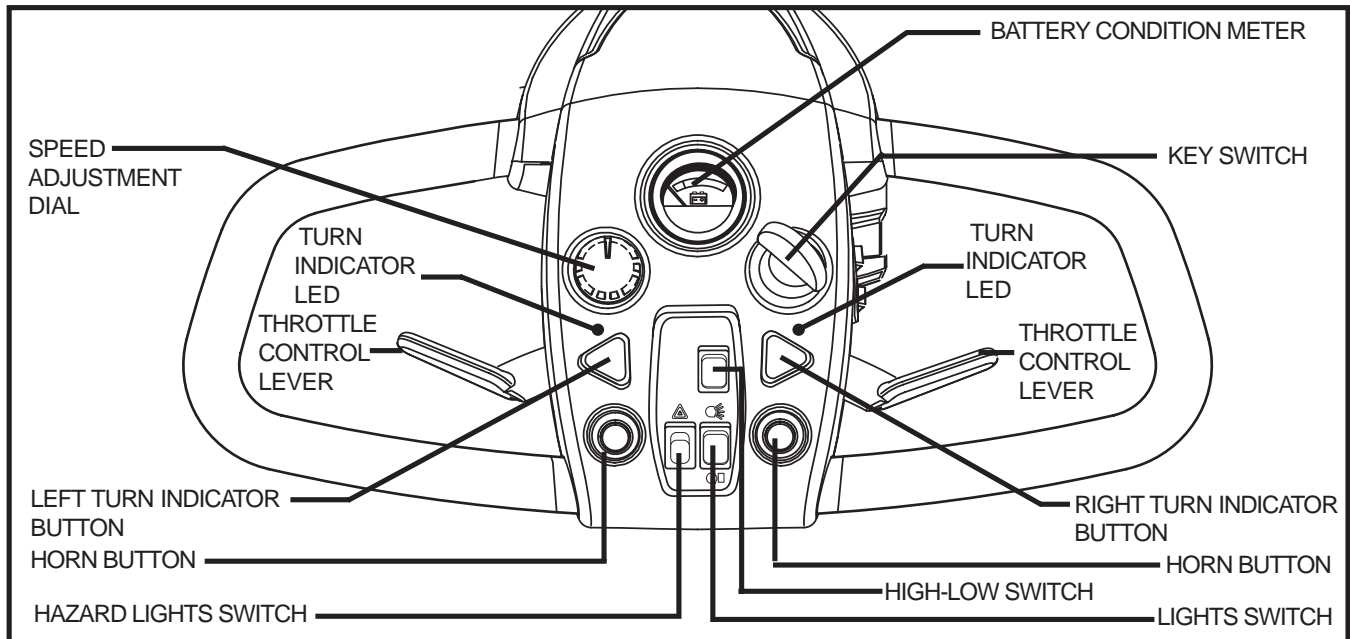

Figure 5. Tiller Console

Horn Buttons

These buttons activate a warning horn. Your scooter must be powered up for the horn to be operational. Do not hesitate to use the warning horn when doing so may prevent an accident.

Key Switch

- Insert the key into the key switch and turn it clockwise to power up (turn on) your scooter.
- Turn the key anticlockwise to power down (turn off) your scooter.



WARNING! If the key is moved to the "off" position while your scooter is in motion, the electronic brakes will engage and your scooter will come to an abrupt stop!

Battery Condition Meter

When the key is fully inserted and turned clockwise to power up your scooter, this meter indicates the approximate battery voltage strength. For further information on battery charging, see VI. "Batteries and Charging."

Turn Indicator Buttons

Use these buttons to turn on the left and right turn indicator (amber) lights. **See figure 5.**

- Push the left button to activate the left turn indicator light and left turn indicator LED.
- Push the right button to activate the right turn indicator light right turn indicator LED.
- The indicators are timed to shut off automatically.

IV. YOUR SCOOTER

High-Low Switch

- Toggle the switch forward (HIGH) and your scooter's maximum speed is 12.87 km/h.
- Toggle the switch rearward (LOW) and your scooter's maximum speed is 6.46 km/h.

Lights Switch

This switch controls your scooter's lights.

- Toggle the switch forward to turn on your scooter's front top light and running lights.
- Toggle the switch to the middle to turn off the scooter's lights.
- Toggle the switch rearward to turn on all the scooter's lights (upper and lower front and running lights).



WARNING! Scooter users are required to use their lights when visibility is restricted—day or night.

Hazard Lights Switch

This switch activates the 4-way flashers on your scooter.

- Toggle the hazard lights switch forward to turn on the flashers.
- Toggle the hazard lights switch rearward to turn off the flashers.

Throttle Control Lever

This lever allows you to control the forward speed and the reverse speed of your scooter up to the maximum speed you preset with the speed adjustment dial.

To Move Forward use either of the following:

- Use your left thumb to push the left side of the throttle control lever.
- Use your right hand fingers to pull back on the right side of the throttle control lever.

To Move Rearward use either of the following:

- Use your right thumb to push the right side of the throttle control lever.
- Use your left hand fingers to pull back on the left side of the throttle control lever.

Release the throttle control lever and allow your scooter to come to a complete stop before engaging the other side of the lever. When the throttle control lever is completely released, it automatically returns to the centre “stop” position and engages your scooter's brakes.

Speed Adjustment Dial

This dial allows you to preselect and limit your scooter's top speed.

- The image of the tortoise represents the slowest speed setting.
- The image of the hare represents the fastest speed setting.

IV. YOUR SCOOTER

Off-board Charger Port

The off-board charger power lead plugs into this port when charging the batteries. See figure 6.

Tiller Console Fuses

These fuses help protect your scooter's front lighting, turn indicators, and key switch console systems from receiving an overload of electrical current. The fuses used in your scooter are the same type used in automobiles. See figure 7. See X. "Care and Maintenance" for fuse replacement.

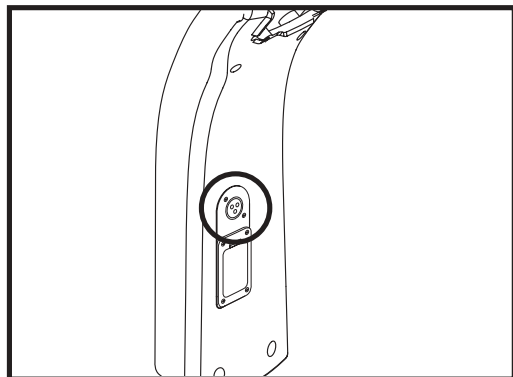

Figure 6. Off-board Charger Port

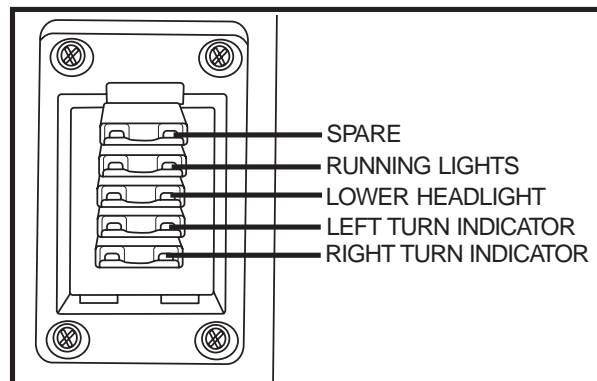

Figure 7. Tiller Console Fuses

REAR SECTION

The batteries, the main circuit breaker (reset button), the manual freewheel lever, the anti-tip wheels, and the motor/transaxle assembly are located on the rear section of your scooter. See figure 8.

Batteries

The batteries store the electrical energy that powers your scooter. See V. "Batteries and Charging" for information on how to charge your scooter batteries.

Motor/Transaxle Assembly

The motor/transaxle assembly is an electromechanical unit that converts electrical energy from your scooter's batteries into the controlled mechanical energy that drives the scooter's wheels.

Anti-tip Wheels

The anti-tip wheels are an integral and important safety feature designed to help prevent your scooter from tipping rearwards on an incline. They are bolted to the frame at the rearmost part of your scooter. See figure 8.

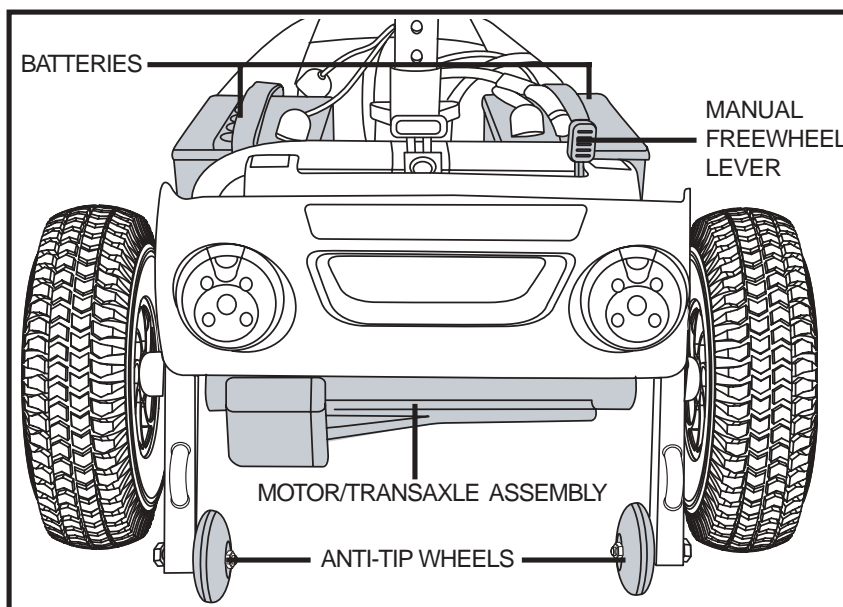

Figure 8. Rear Section



PROHIBITED! Do not remove the anti-tip wheels or modify your scooter in any way that is not authorised by Pride.

IV. YOUR SCOOTER

Manual Freewheel Lever

Whenever you need or want to push your scooter for short distances, you can put it in freewheel mode.

1. Remove the key from the key switch.
2. Push forward on the manual freewheel lever to disable the drive system and the brake system. You may now push your scooter.
3. Pull back on the manual freewheel lever to reengage the drive and the brake systems and take your scooter out of freewheel mode.



WARNING! When your scooter is in freewheel mode, the braking system is disengaged.

- Disengage the drive motors only on a level surface.
- Ensure the key is removed from the key switch.
- Stand to the side of the scooter to engage or disengage freewheel mode. Never sit on a scooter to do this.
- After you have finished pushing your scooter, always return it to the drive mode to lock the brakes.

NOTE: *If the scooter is placed in freewheel mode (manual freewheel lever forward) while the key is in the “on” position, the scooter will not run until the manual freewheel lever is pushed rearward and the key is turned to the “off” position, then back to the “on” position.*

Safety Flag Bracket

An accessory bracket for installing an optional safety flag is mounted near each anti-tip wheel. To install the flag, the supplied “L” shaped hex key is needed. See **figure 8A**.

To install the flag bracket:

1. Remove the cap from the top of the bracket.
2. Loosen the setscrew with the supplied “L” shaped hex key.
3. Insert the flag pole into the opening.
4. Tighten the setscrew to complete installation.

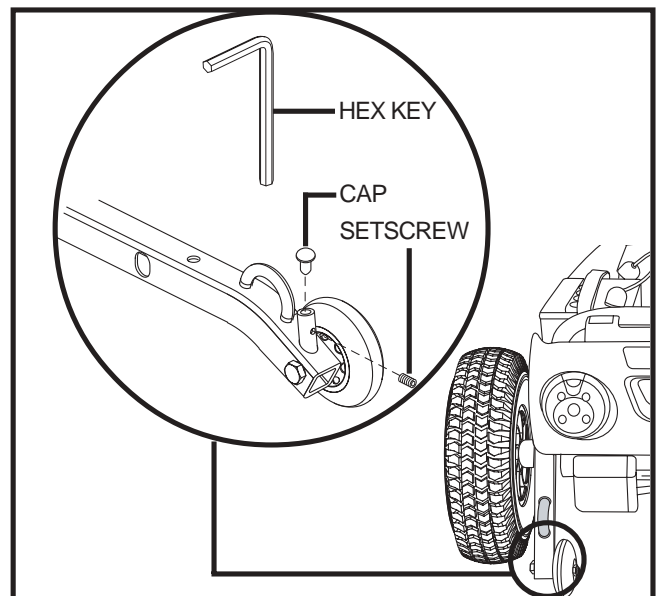

Figure 8A. Safety Flag Bracket

IV. YOUR SCOOTER

Main Circuit Breaker (Reset Button)

When the voltage in the batteries becomes low or your scooter is heavily strained because of excessive loads, the main circuit breaker may trip to protect the motor and electronics from damage. When the breaker trips, the entire electrical system shuts down. **See figure 9.**

- The reset button pops out when the breaker trips.
- Allow a minute or so for the electronics to “rest.”
- Push in the reset button to reset the breaker.
- If the breaker trips frequently, you may need to charge the batteries more often or have your authorised Pride Provider perform a load test on the batteries.

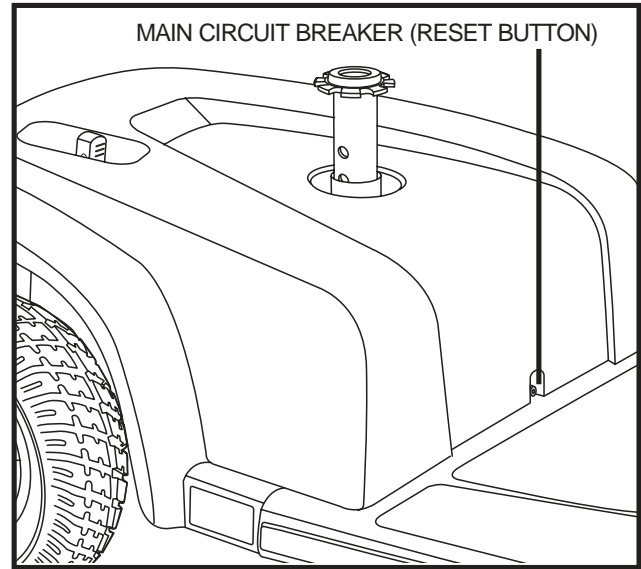

Figure 9. Main Circuit Breaker (Reset Button)

SECUREMENT POINTS

Steel loops welded to the anti-tip wheel brackets and/or front frame components of your scooter provide securement points. **See figures 10 and 10A.** These should only be used with an unoccupied scooter and secured by an approved securement system in accordance with the manufacturer's instructions. Pride makes no representation of suitability for use with specific securement systems nor can we anticipate the various situations that might arise in use of public transportation systems. For detailed instructions on the use of securement systems, refer to the applicable municipal transit authority and/or manufacturer of the system used.



WARNING! DO NOT leave the scooter in freewheel mode when securing it for transport.

WARNING! DO NOT use your scooter as a seat in a moving vehicle.

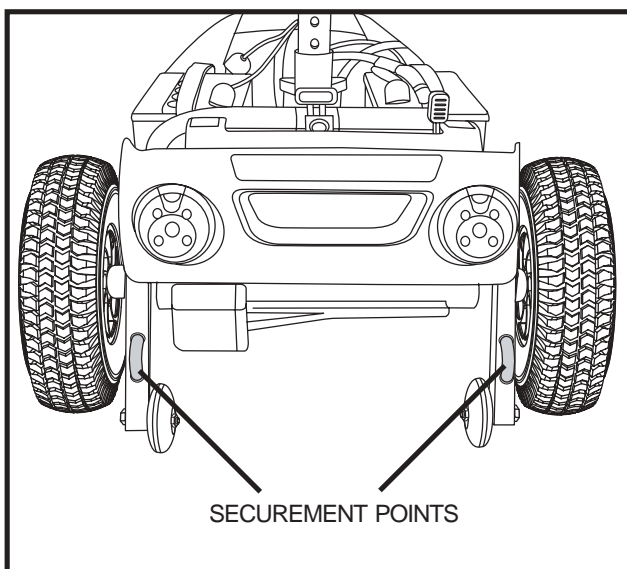

Figure 10. Rear Securement Points

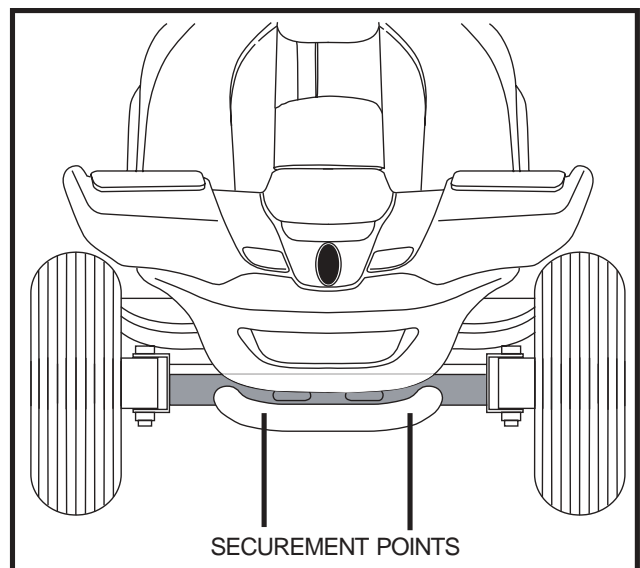

Figure 10A. Front Securement Points

V. BATTERIES AND CHARGING

Your scooter requires two long-lasting, 12-volt, deep-cycle batteries that are sealed and maintenance free. They are recharged by an off-board charging system.

- Charge your scooter's batteries prior to using it for the first time.
- Keep the batteries fully charged to keep your scooter running smoothly.

READING YOUR BATTERY VOLTAGE

The battery condition meter on the tiller console indicates the approximate strength of your batteries using a colour code. From right to left, green indicates fully charged batteries, yellow a draining charge, and red indicates that an immediate recharge is necessary. **See figure 11.** To ensure the highest accuracy, the battery condition meter should be checked while operating your scooter at full speed on a dry, level surface.

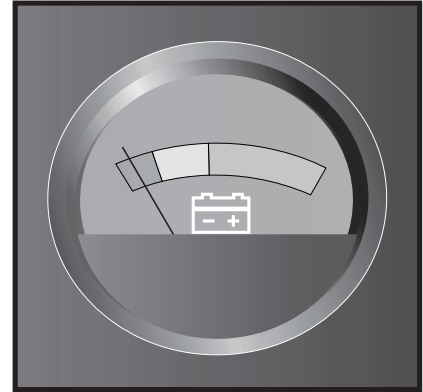

Figure 11. Battery Condition Meter

CHARGING YOUR BATTERIES



PROHIBITED! Never use an extension lead to plug in your battery charger. Plug the charger directly into a properly wired standard electrical outlet.



PROHIBITED! Removal of the grounding prong can create an electrical hazard. If necessary, properly install an approved 3-pronged adapter to an electrical outlet having 2-pronged plug access.

WARNING! Ensure that both ends of the charger power lead are clean and dry before plugging the charger power lead into the off-board charger port or the electrical outlet.

WARNING! Read the battery charging instructions in this manual and in the manual supplied with the battery charger before charging the batteries.

WARNING! Do not expose the off-board battery charger to rain or other sources of moisture unless it has been tested for outdoor use. Refer to the manual supplied with the battery charger for more information.

WARNING! Explosive gases may be generated while charging the batteries. Keep the scooter and the battery charger away from sources of ignition such as flames or sparks and provide adequate ventilation when charging the batteries.



WARNING! Inspect the battery charger, wiring, and connectors for damage before each use. Contact your authorised Pride Provider if damage is found.

WARNING! Do not attempt to open the battery charger case. If the battery charger does not appear to be working correctly, contact your authorised Pride Provider.

WARNING! If the off-board battery charger is equipped with cooling slots, then do not attempt to insert objects through these slots.

WARNING! Do not allow unsupervised children to play near the scooter while the batteries are charging. Pride recommends that you do not charge the batteries while the scooter is occupied.

WARNING! If your off-board battery charger has not been tested and approved for outdoor use, then do not expose it to adverse or extreme weather conditions. If the battery charger is exposed to adverse or extreme weather conditions, then it must be allowed to adjust to the difference in environmental conditions before use indoors. Refer to the manual supplied with the battery charger for more information.

V. BATTERIES AND CHARGING

The off-board charger supplied with your scooter is equipped with a 115/230 voltage switch. Confirm that this switch is in the proper position for your locality. If you are not sure what the voltage is in your country, contact your local electricity provider before inserting the charger power lead plug into your electrical outlet. If the setting is incorrect, the charger will not function properly. Slide the voltage switch to the appropriate position. **See figure 12.**

The LED lights on the charger indicate different charger conditions at various times: charger power on, charging in progress, charging complete. Refer to the label on the charger for a complete explanation of these indicators.

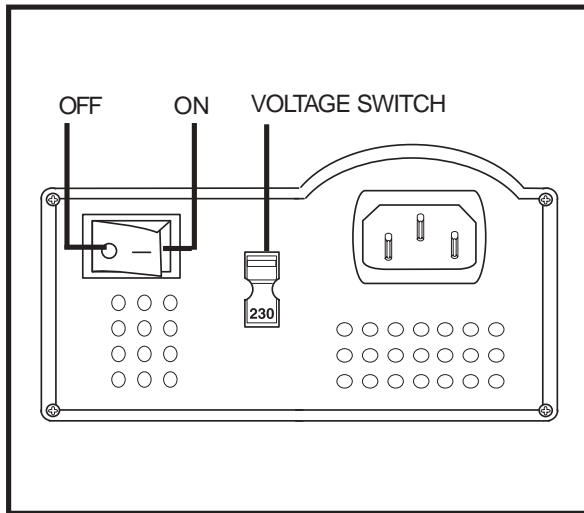

Figure 12. Charger On/Off and Voltage Switches

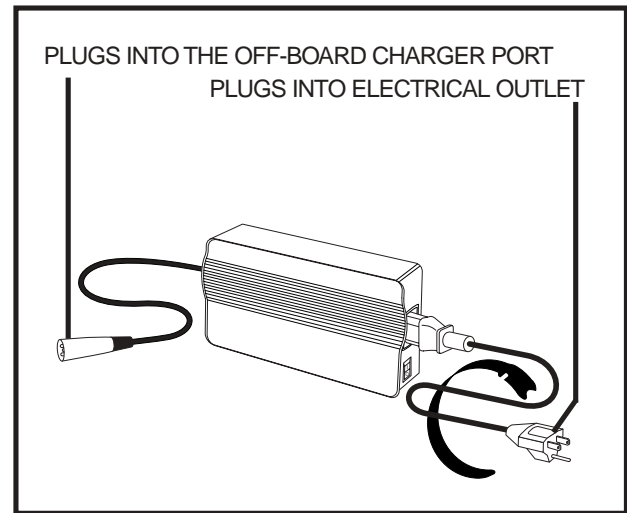

Figure 12A. Off-board Charger

Follow these easy steps to charge your batteries safely:

1. Position the front of your scooter close to a standard electrical outlet.
2. Remove the key from the key switch.
3. Make certain that the manual freewheel lever is in the drive position.
4. Plug the 3-pin charger power lead into the off-board charger port. **See figure 12A.**
5. Make sure the charger's on/off switch is in the OFF position.
6. Extend the charger power lead and plug it into the electrical outlet.
7. Turn the charger on. **See figure 12.** We recommend that you charge the batteries for 8 to 14 hours.
8. When the batteries are fully charged, turn the charger off and unplug the charger power lead from the electrical outlet and then from the off-board charger port.

NOTE: *There is a charger inhibit function on your scooter. The scooter will not run and the battery condition meter will not operate while the batteries are charging.*

V. BATTERIES AND CHARGING

FREQUENTLY ASKED QUESTIONS

How does the charger work?

When your scooter's battery voltage is low, the charger works harder, sending more electrical current to the batteries to bring up their charge. As the batteries approach a full charge, the charger sends less and less electrical current. When the batteries are fully charged, the current sent from the charger is at nearly zero amperage. Therefore, when the charger is plugged in, it maintains the charge on your scooter's batteries, but does not overcharge them. We do not recommend that you charge your scooter's batteries for more than 24 consecutive hours.

Can I use a different charger?

Chargers are selected precisely for particular applications and are especially matched to the type, size, and chemical formulation of specific batteries. For the safest and most efficient charging of your scooter's batteries, we recommend use of the charger supplied as original equipment with your Pride product only. Any charging method resulting in batteries being charged individually is especially prohibited.

What if my scooter's batteries won't charge?

- Ensure the red (+) and black (-) battery cables are connected properly to the battery terminals.
- Ensure both battery harnesses that extend from the batteries are plugged into their mating harness leading to the charger.
- Ensure both ends of the charger power lead are inserted fully.

How often must I charge the batteries?

Two major factors must be considered when deciding how often to charge your scooter's batteries:

- All day scooter use on a daily basis.
- Infrequent or sporadic scooter use.

With these considerations in mind, you can determine how often and for how long you should charge your scooter's batteries. We designed the off-board charger so that it will not overcharge your scooter's batteries. However, you may encounter some problems if you do not charge your batteries often enough and if you do not charge them on a regular basis. Following the guidelines below will provide safe and reliable battery operation and charging.

- If you use your scooter daily, charge its batteries as soon as you finish using it for the day. Your scooter will be ready each morning. We recommend that you charge your scooter's batteries for 8 to 14 hours after daily use.
- If you use your scooter once a week or less, charge its batteries at least once a week for 12 to 14 hours at a time.
- Keep your scooter's batteries fully charged.
- Avoid deeply discharging your scooter's batteries.

How can I ensure maximum battery life?

Fully charged deep-cycle batteries provide reliable performance and extended battery life. Keep your scooter's batteries fully charged whenever possible. Protect your scooter and batteries from extreme heat or cold. Batteries that are regularly and deeply discharged, infrequently charged, stored in extreme temperatures, or stored without a full charge may be permanently damaged, causing unreliable performance and limited service life.

V. BATTERIES AND CHARGING

- Always fully charge your scooter's batteries prior to daily use.
- Maintain **2-2.4 bar (30-35 psi)** in each tyre.
- Plan your route ahead to avoid as many hills, cracked, broken, or soft surfaces as possible.
- Limit your baggage weight to essential items.
- Try to maintain an even speed while your scooter is in motion.
- Avoid stop-and-go driving.

What type and size of battery should I use?

We recommend deep-cycle batteries that are sealed and maintenance free. Both AGM and Gel-Cell are deep-cycle batteries that are similar in performance. Do not use wet-cell batteries, which have removable caps.



WARNING! Corrosive chemicals are contained in batteries. Use only AGM or Gel-Cell batteries to reduce the risk of leakage or explosive conditions.

NOTE: Sealed batteries are not serviceable. Do not remove the caps.

How do I change a battery in my scooter?



WARNING! Do not mix or match new and old batteries. If you encounter a situation where one battery needs to be replaced, then replace both batteries. Refer to specifications table in this manual and the manual supplied with the battery charger for recommended type and capacities.

WARNING! Battery posts, terminals, and related accessories contain lead and lead compounds. Wash hands after handling.

1. Remove the seat and rear shroud. See VIII. "Disassembly and Assembly."
2. Disconnect the battery tie-down strap.
3. Disconnect the battery harnesses by pulling it straight up. **See figure 13.**
4. Disconnect the battery cables from the battery terminals.
5. Remove the old batteries.
6. Place new batteries in the battery well. Face the battery terminals of each battery toward the seat post.
7. Connect the red battery cable to the positive (+) battery terminal. **See figure 13A.**
8. Connect the black battery cable to the negative (-) battery terminal on each battery.
9. Ensure the battery terminals are covered with the tiller boots.

NOTE: See figure 13B for correct hardware placement for battery terminal connections.

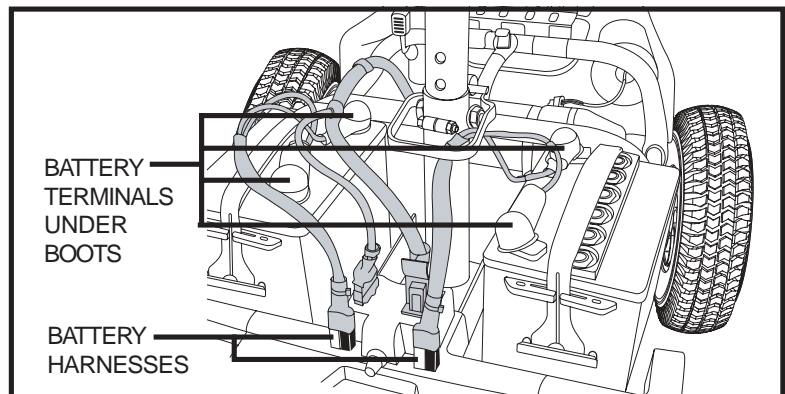

Figure 13. Battery Harnesses and Battery Cables

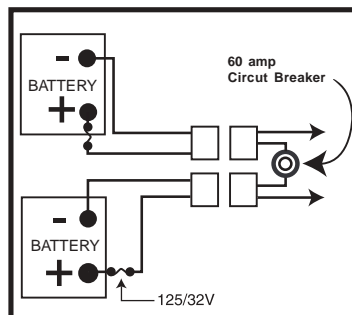

Figure 13A. Battery Cable Orientation

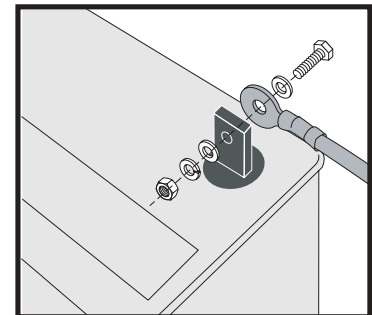

Figure 13B. Cable To Terminal Connection

V. BATTERIES AND CHARGING

10. Reconnect the battery harnesses.
11. Reconnect the battery tie-down strap—making sure the strap is positioned over the frame release lever to ensure proper securement. See **figure 13C**.
12. Reinstall the rear shroud and seat.

NOTE: *If you encounter a damaged or cracked battery, immediately enclose it in a plastic bag and call your authorised Pride Provider for instructions on disposal. Your authorised Pride Provider will also have the necessary information on battery recycling, which is our recommended course of action.*

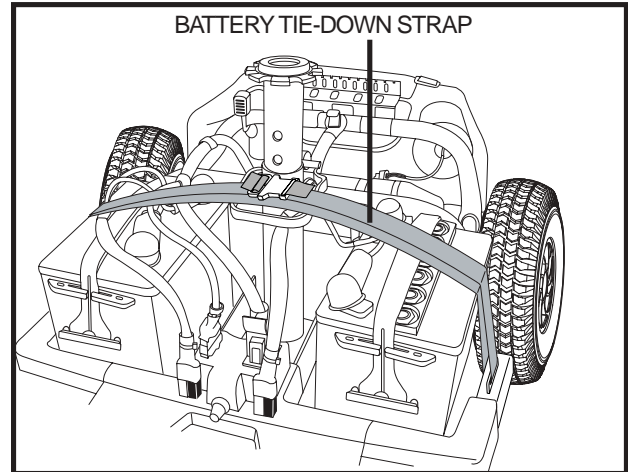

Figure 13C. Battery Tie-Down Strap

Why do my new batteries seem weak?

Deep-cycle batteries employ a different chemical technology than that used in car batteries, nickel-cadmium batteries (nicads) and other common battery types. Deep-cycle batteries are specifically designed to provide power, drain down their charge, and then accept a relatively quick recharge.

We work closely with our battery manufacturer to provide batteries that best suit your scooter's specific electrical demands. Fresh batteries are shipped fully charged to our customers. During shipping, the batteries may encounter temperature extremes that can influence their initial performance. Heat diminishes the charge on the battery; cold slows the available power and extends the time needed to recharge the battery.

It may take a few days for the temperature of your scooter's batteries to stabilize and adjust to their new room or ambient temperature. More importantly, it takes a few charging cycles (partial draining followed by full recharging) to establish the critical chemical balance that is essential to a deep-cycle battery's peak performance and long life.

Follow these steps to properly break in your scooter's new batteries for maximum efficiency and service life.

1. Fully recharge any new battery prior to its initial use. This charging cycle brings the battery up to about 88% of its peak performance level.
2. Operate your new scooter in familiar and safe areas. Drive slowly at first and do not travel too far from your home or familiar surroundings until you have become accustomed to your scooter's controls and have properly broken in your scooter's batteries.
3. Fully recharge the batteries. They should be at over 90% of their peak performance level.
4. Operate your scooter again.
5. Fully recharge the batteries again.
6. After four or five charging cycles, the batteries are able to receive a charge of 100% of their peak performance level and are able to last for an extended period of time.

What about public transport?

If you intend to use public transport with your scooter, you must contact the transportation Provider in advance to determine their specific requirements.

VI. OPERATION

BEFORE GETTING ONTO YOUR SCOOTER

- Have you fully charged the batteries? See V. “Batteries and Charging.”
- Is the manual freewheel lever in the drive (rearward) position? Never leave the manual freewheel lever pushed forward unless you are manually pushing your scooter.
- Is the tiller lock knob in the unlocked position? See VIII. “Disassembly and Assembly.”

GETTING ONTO YOUR SCOOTER

1. Make certain that the key is removed from the key switch.



WARNING! Never attempt to get onto or off of your scooter without first removing the key from the key switch. This will prevent the scooter from moving if accidental throttle control lever contact is made.

2. Stand at the side of your scooter.
3. Disengage the seat rotation lever and rotate the seat until it is facing you.
4. Make certain that the seat is securely in position.
5. Position yourself comfortably and securely in the seat.
6. Disengage the seat rotation lever and rotate the seat until you are facing forward.
7. Make certain that the seat is securely in position.
8. Make certain that your feet are safely on the floorboard.

PRE-RIDE ADJUSTMENTS AND CHECKS

- Is the seat at the proper height? See VII. “Comfort Adjustments.”
- Is the seat securely in place?
- Is the tiller at a comfortable setting and locked securely in place? See VII. “Comfort Adjustments.”
- Is the key fully inserted into the key switch and turned clockwise to the “on” position?
- Does the scooter’s horn work properly?
- Is your proposed path clear of people, pets, and obstacles?
- Have you planned your route to avoid adverse terrain and as many inclines as possible?

OPERATING YOUR SCOOTER

WARNING! The following can adversely affect steering and stability while operating your scooter:



- Holding onto or attaching a leash to walk your pet
- Carrying passengers (including pets)
- Hanging any article from the tiller
- Towing or being pushed by another motorised vehicle

Such practices could cause loss of control and/or tipping.

Keep both hands on the tiller and your feet on the floorboard at all times while operating your scooter. This driving position gives you the most control over your vehicle.

- Set the speed adjustment dial to your desired speed.

VI. OPERATION

- Push or pull the appropriate side of the throttle control lever.
- The electromechanical disc park brake automatically disengages and the scooter accelerates smoothly to the speed you preselected with the speed adjustment dial.
- Pull on the left handgrip to steer your scooter to the left.
- Pull on the right handgrip to steer your scooter to the right.
- Move the tiller to the centre position to drive straight ahead.
- To stop, slowly release the throttle control lever. The electronic brakes will automatically engage, bringing your scooter to a stop.

NOTE: Your scooter's reverse speed is slower than that of the forward speed you preset with the speed adjustment dial.

GETTING OFF YOUR SCOOTER

1. Bring your scooter to a complete stop.
2. Remove the key from the key switch.
3. Disengage the seat rotation lever and rotate the seat until you are facing toward the side of your scooter.
4. Make certain that the seat is secured into position.
5. Carefully and safely get out of the seat and stand to the side of your scooter.
6. You can leave the seat facing to the side to facilitate boarding your scooter next time.

POWER DOWN TIMER FEATURE

Your scooter is equipped with an energy saving automatic power down timer feature designed to preserve your scooter's battery life. If you mistakenly leave the key in the key switch and in the "on" position but do not use your scooter for approximately 20 minutes, the scooter's controller shuts down automatically. Although the controller is shut down, power will still be supplied to the scooter's lighting system.

If the power down timer feature takes effect, perform the following steps to resume normal operation.

1. Remove the key from the key switch.
2. Reinsert the key and power up your scooter.

VII. COMFORT ADJUSTMENTS

TILLER ANGLE ADJUSTMENT

Your scooter is equipped with an adjustable pivoting tiller.



WARNING! Remove the key from the key switch before adjusting the tiller, console, or the seat. Never attempt to adjust the tiller or the seat while the scooter is in motion.

To change the tiller angle:

1. Squeeze the tiller adjustment lever. See figure 14.
2. Move the tiller to a comfortable position.
3. Release the tiller adjustment lever to secure the tiller into place.

NOTE: In order to fully lower the tiller, you must first remove the seat. Remove the seat by pulling it straight up and off of the scooter.

TILLER CONSOLE ANGLE ADJUSTMENT

The tiller console can be adjusted to different angles.

To change the console angle:

1. Loosen the adjustment dial (turn anticlockwise) and move the tiller console up or down to a comfortable riding position. See figure 14.
2. Hold the console at that position and tighten (turn clockwise) the adjustment dial.

ARMREST ANGLE ADJUSTMENT

The armrest angle of your scooter can be adjusted upward or downward by turning the adjustment dial. See figure 15.

NOTE: Pivot the armrests upward to make getting onto and off of your scooter easier.

SEATBACK ADJUSTMENT



WARNING! Do not operate your scooter with the seatback in a reclined position.

WARNING! Always keep your back pressed firmly against the seatback while adjusting the angle.

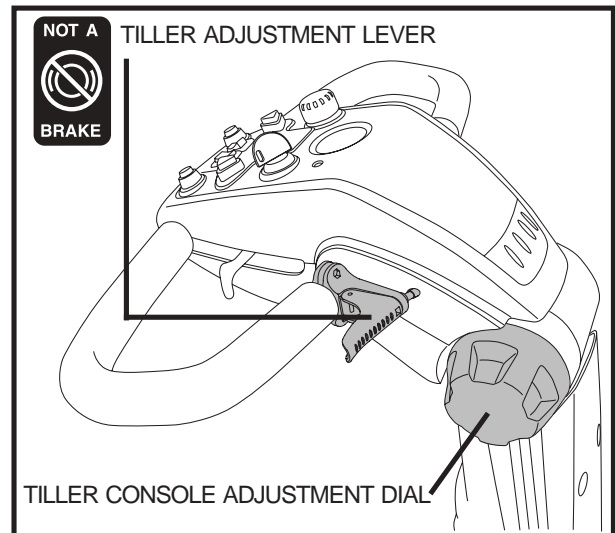

Figure 14. Tiller/Tiller Console Adjustment

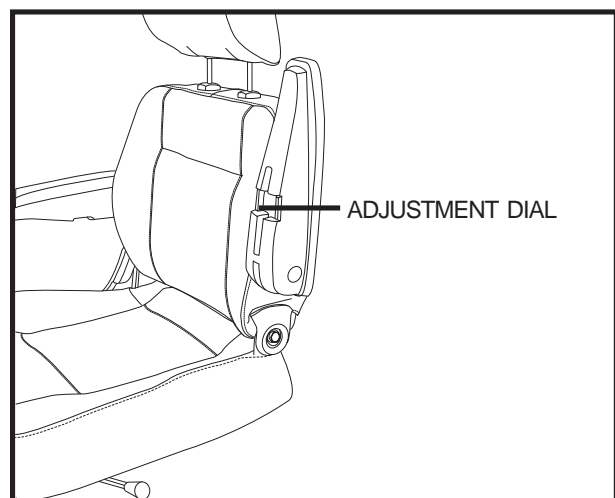

Figure 15. Armrest Angle Adjustment

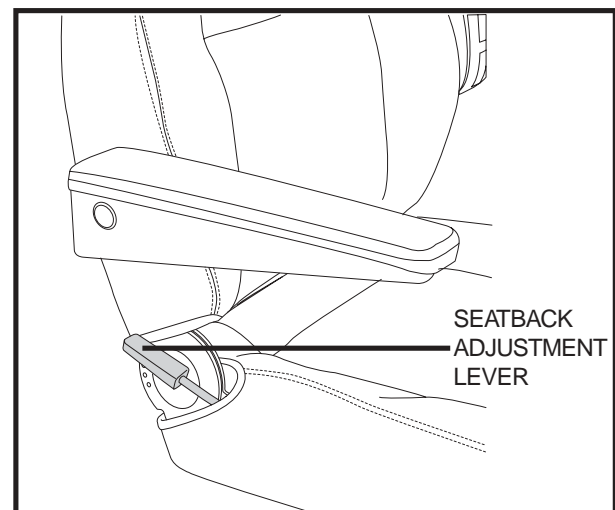

Figure 16. Seatback Adjustment

VII. COMFORT ADJUSTMENTS

To adjust your scooter's reclining seat, perform these steps. **See figure 16.**

1. With your back pressed up against the seatback, lift up on the seatback adjustment lever and lean forward or rearward to adjust the seatback angle.
2. Release the seatback adjustment lever once the seat is in a comfortable riding position.

SEAT ROTATION ADJUSTMENT

The seat rotation lever will secure the seat into several positions.

1. Push forward on the seat rotation lever to disengage the seat. **See figure 16A.**
2. Rotate the seat to the desired position.
3. Release the lever to secure the seat into place.

FRONT-TO-BACK SEAT ADJUSTMENT

You can reposition the seat forward or rearward to adjust the distance between the seat and the tiller. **See figure 16A.**

1. Move the seat sliding lever outward.
2. While holding the lever out, slide the seat forward or rearward.
3. Release the seat sliding lever once the seat is in the desired position.

SEAT HEIGHT ADJUSTMENT

The seat can be repositioned to different heights. **See figure 17.**

1. Remove the seat and rear shroud from your scooter. **See VIII. "Disassembly and Assembly."**
2. Loosen the seat height adjustment nut and remove it from the bolt. Remove the bolt.
3. Loosen the clamp-action bolt.
4. Raise or lower the upper seat post to the desired seat height.
5. While holding the upper seat post at that height, match up the locating holes in the upper seat post with those of the lower seat post.
6. Insert the seat height adjustment bolt through the locating holes of both the upper and lower seat posts.
7. Install the nut onto the bolt and tighten.
8. Tighten the clamp-action bolt.
9. Reinstall the rear shroud and the seat.

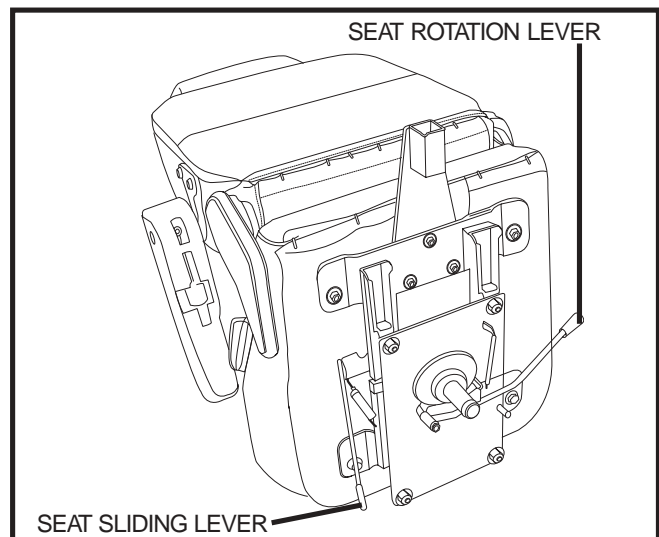

Figure 16A. Seat Adjustment Levers

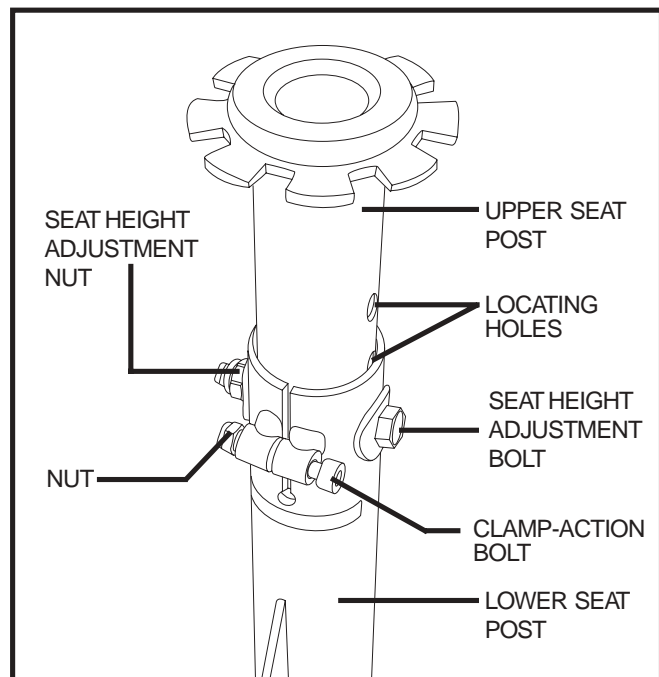

Figure 17. Seat Height Adjustment

VII. COMFORT ADJUSTMENTS

MIRROR POSITION

To install the mirror (see figure 18):

1. Determine a side to install the mirror and remove the rubber plug from the top of the tiller handle.
2. Insert the threaded end of the mirror holder into the opening and rotate it clockwise until snug.
3. If necessary, rotate the nut clockwise to secure the mirror in place.

To adjust the mirror:

1. Position yourself in a seated driving position facing forward.
2. Adjust the mirror left, right, up, or down until you have a good line of sight behind you.

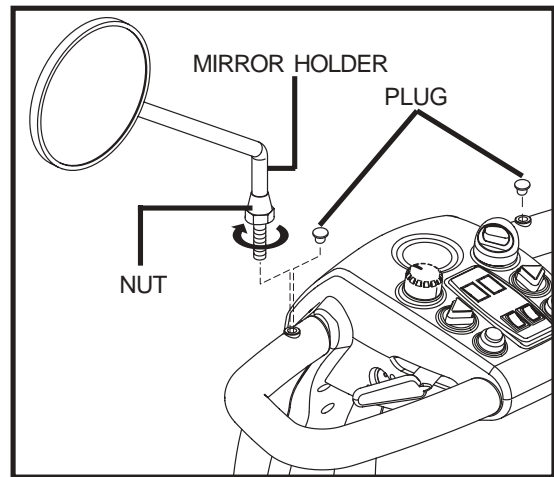

Figure 18. Mirror Installation

POSITIONING BELT (OPTIONAL)

Your scooter seat may be equipped with an auto-type positioning belt that can be adjusted for operator comfort. See figure 19. The positioning belt is designed to help support the operator so that he/she does not slide down or forward in the seat. The positioning belt is not designed for use as a restraining device.

To install the positioning belt (if required):

1. Remove the seat from your scooter.
2. Place the seat upside down so that you can see the bottom of the seat base.
3. Remove the two bolts on the outermost part of the rear seat mounting strap.
4. Insert the bolt through the appropriate end of the positioning belt and then through the seat mounting strap for each side of the scooter seat.
5. Tighten the bolts.



Figure 19. Positioning Belt

To adjust the positioning belt for operator comfort:

1. Insert the metal tab on the right side of the belt into the plastic housing on the opposite strap until you hear a “click.”
2. Pull the strap on the right side of the belt until it is secure, but not so tight as to cause discomfort.



MANDATORY! Make sure the positioning belt is properly secured to the scooter and is adjusted for operator comfort.

MANDATORY! Inspect the positioning belt for loose or damaged parts before each use of the scooter. If you discover a problem, contact your authorised Pride Provider for maintenance and repair.

VIII. DISASSEMBLY AND ASSEMBLY

DISASSEMBLY

You can disassemble the scooter into seven pieces: the seat, the front section, the rear section, the rear shroud, the basket, and the batteries. **See figure 20.** No tools are required to disassemble or assemble your scooter, but keep in mind that the disassembled sections of the scooter take up more floor space than when assembled. Always disassemble or assemble your scooter on a level, dry surface with sufficient room for you to work and move around your scooter—about 2 metres in all directions. Remember that some scooter components are heavy and you may need assistance when lifting them.



WARNING! Do not lift weight beyond your physical capability. Ask for assistance when necessary while disassembling or assembling your scooter.

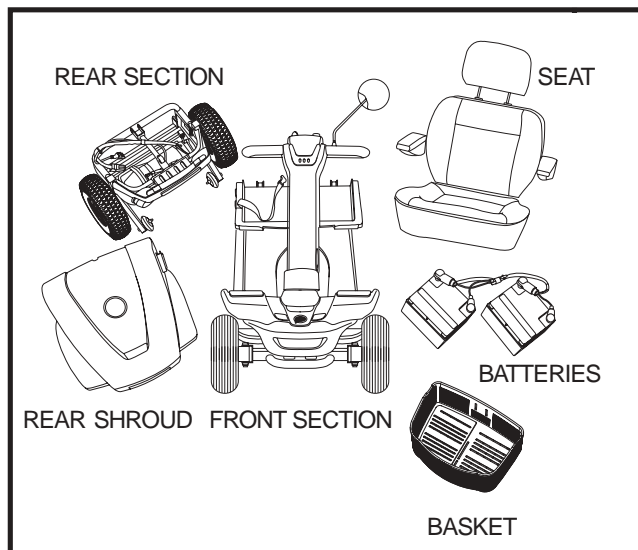

Figure 20. Disassembled Scooter

1. Place the scooter in drive mode by engaging the freewheel lever.
2. Secure the tiller in the straight ahead position by pushing the tiller lock knob in and turning it clockwise 90°. **See figure 21.** The front wheel must face forward in order to lock the tiller.
3. Remove the seat by lifting it straight up and off of the scooter. If you encounter resistance when removing the seat, disengage the seat rotation lever and swivel the seat back and forth while lifting up on the seat.
4. Gently pull the rear shroud up and off of the rear section of the scooter.
5. Unplug the front-to-rear and rear lighting harnesses by squeezing the sides and pulling straight up. **See figure 22.**

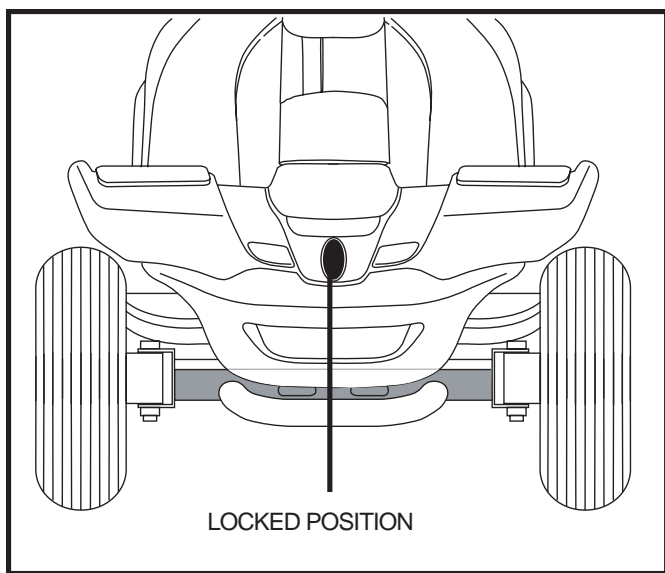

Figure 21. Tiller Lock Knob (Locked)

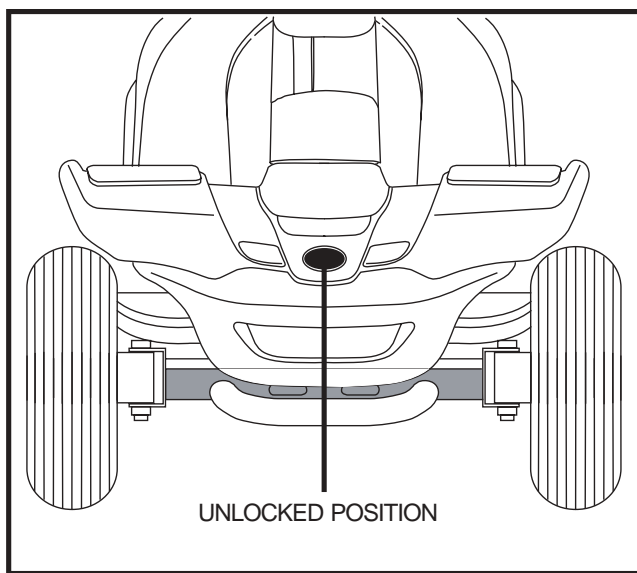

Figure 21A. Tiller Lock Knob (Unlocked)

VIII. DISASSEMBLY AND ASSEMBLY

6. Unplug both battery harnesses. Pull each harness straight up. **See figure 22.**
7. Unfasten the battery tie-down strap and remove the batteries from the battery wells.



WARNING! Failure to unplug both battery harnesses, the front-to-rear harness, and rear lighting harness prior to separating the front and rear sections could result in permanent damage to the scooter.

Frame Separation

1. Squeeze the tiller adjustment lever and lower the tiller to its lowest point.
2. Lift up on the frame release lever. **See figure 23.**
3. Lift the front section up until the frame hooks of the front section separate from the rear section. **See figure 24.**

NOTE: Stabilise the rear section with your free hand by holding onto the upper frame tube. **See figure 26.**

4. Slowly separate the two sections. **See figure 24.**

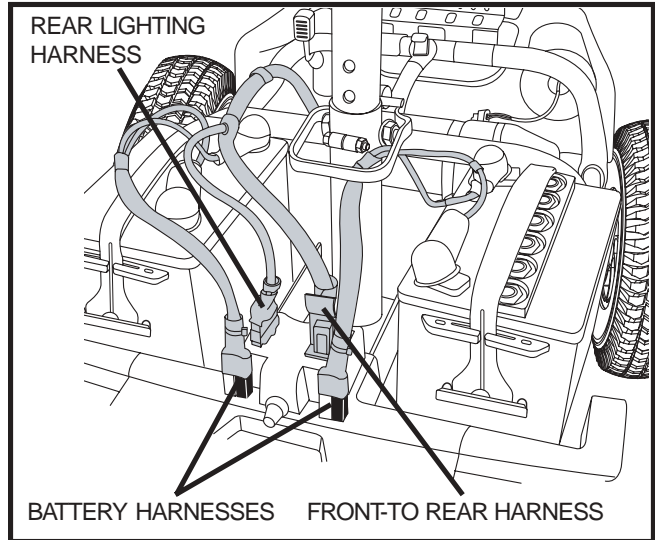

Figure 22. Harness Connections

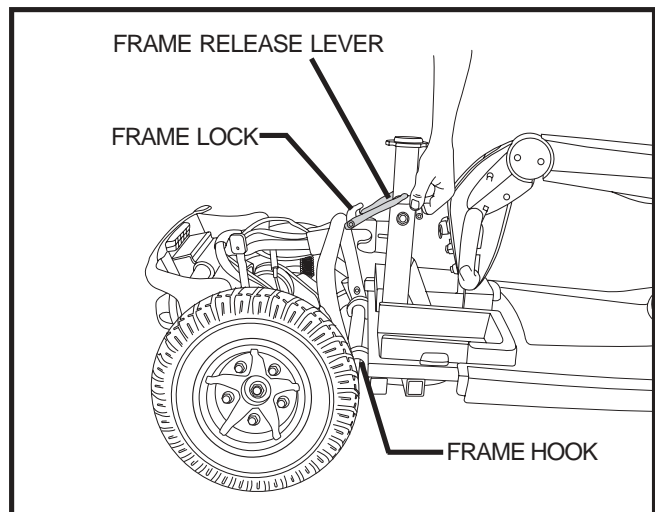

Figure 23. Frame Release

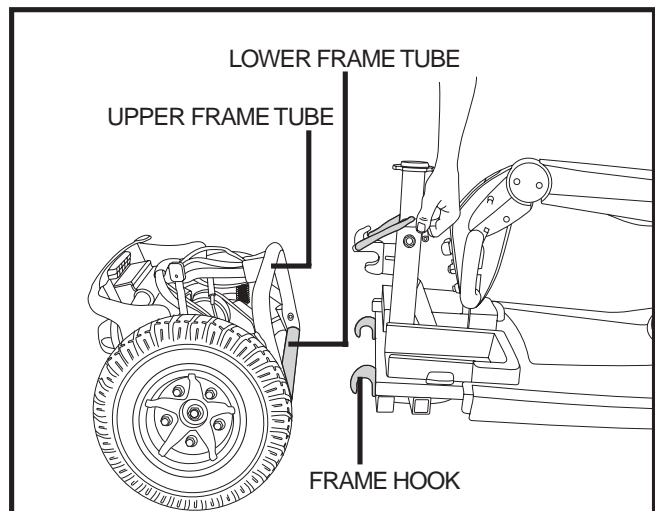

Figure 24. Frame Separation

VIII. DISASSEMBLY AND ASSEMBLY

ASSEMBLY

1. Position the front and rear sections of your scooter as shown in **figure 24**.
2. Use the frame release lever to lift the front section as you align the frame hooks of the front section with the lower frame tube of the rear section. **See figure 23**.
3. Once the frame hooks are over the lower frame tube, lower the front section completely. This will engage the frame lock. **See figure 23**.
4. Raise the tiller.
5. Reinstall both batteries and secure with tie-down straps—making sure the strap is positioned over the frame release lever to ensure proper securement.
6. Connect the front-to-rear harness, rear lighting harness, and both battery harnesses. **See figure 22**.
7. Reinstall the rear shroud.
8. Reinstall the seat and rotate it securely into place.
9. Unlock the front wheel by turning the tiller lock knob 90° anticlockwise. **See figure 21A**.



WARNING! After assembly, make absolutely certain the tiller lock knob is in the unlocked position before riding your scooter.

IX. BASIC TROUBLESHOOTING

Any electromechanical device occasionally requires some troubleshooting. However, most of the problems that may arise can usually be solved with a bit of thought and common sense. Many of these problems occur because the batteries are not fully charged or because the batteries are worn down and can no longer hold a charge.

DIAGNOSTIC BEEP CODES

The diagnostic beep codes for your scooter are designed to help you perform basic troubleshooting quickly and easily. A diagnostic beep code will sound in the event one of the conditions listed below develops.

NOTE: *Your scooter will not run unless the beep code condition is resolved and the scooter has been turned off, then turned back on.*

BEEP CODE	CONDITION	SOLUTION
■ ■ (1,1)	Controller is hot; the scooter seems to be losing power.	Shut down your scooter for a minimum of several minutes to allow the controller to cool.
■ ■■■■ (1,4) ■ ■ ■ ■ (3,3)	Battery charge is low.	Charge batteries as soon as possible.
■ ■■ (1,2)	Throttle pot fault	Contact your authorised Pride Provider for assistance.
■ ■■■ (1,3)	Speed pot fault	Contact your authorised Pride Provider for assistance.
■ ■■■■■ (1,5)	Attempting to operate the scooter with the charger attached.	Turn the scooter key to the off position. Switch off the charger and removed cord from the charger port, then restart your scooter.
■■■ ■■■■■ (3,5)	Throttle control lever not at center position at start up.	Return the throttle control lever to center position, turn scooter off, and then back on.
■■■ ■■■■ (3,4)	The manual freewheel lever may be in the freewheel (forward) position.	Turn the scooter key to the off position. Push the freewheel lever to the drive (rearward) position, then restart your scooter.
■■■ ■■ (3,2)	A brake fault has occurred.	Contact your authorised Pride Provider for assistance.

What if all the systems on my scooter seem to be “dead”?

- Make certain that the key is in the “on” position.
- Check that the batteries are fully charged.
- Push in the main circuit breaker reset button. See IV. “Your Scooter.”
- Make certain that both battery harnesses and the front-to-rear harness are firmly connected. See VIII. “Disassembly and Assembly.”
- Be sure the power down timer feature hasn’t been activated. See VI. “Operation.”

IX. BASIC TROUBLESHOOTING

What if my scooter does not move when I engage the throttle control lever?

- When the manual freewheel lever is pushed forward, the brakes are disengaged and all power to the motor/transaxle assembly is cut.
- Push rearward on the manual freewheel lever, turn the scooter off and then turn the scooter on to return to normal scooter operation.

What if the main circuit breaker repeatedly trips?

- Charge the scooter's batteries more frequently. See V. "Batteries and Charging."
- If the problem continues, have both of your scooter's batteries load tested by your authorised Pride Provider.
- If the main circuit breaker trips repeatedly, contact your authorised Pride Provider for service.
- You may also perform the load test yourself. Battery load testers are available at most automotive parts stores.
- Follow the directions supplied with the load tester.
- See V. "Batteries and Charging" or III. "Specifications" for information about your scooter's battery type.

What if the battery condition meter dips way down and the motor surges or hesitates when I engage the throttle control lever?

- Fully charge your scooter's batteries. See V. "Batteries and Charging."
- Have your authorised Pride Provider load test each battery.
- Or, see the previous troubleshooting question for load testing the batteries yourself.

If you experience any problems with your scooter that you are not able to solve, immediately contact your authorised Pride Provider for information, maintenance, and service.

X. CARE AND MAINTENANCE

Your scooter requires a minimal amount of care and maintenance. If you do not feel confident in your ability to perform the maintenance listed below, you may schedule inspection and maintenance at your authorised Pride Provider. The following areas require periodic inspection and/or care and maintenance.

TYRE PRESSURE

- If equipped with pneumatic tyres, always maintain a proper **2-2.4 bar (30-35 psi)** tyre pressure.



WARNING! It is important that 2-2.4 bar (30-35 psi) tyre pressure be maintained in pneumatic tyres at all times. Do not underinflate or overinflate your tyres. Low pressure may result in loss of control and overinflated tyres may burst. Failure to maintain 2-2.4 bar (30-35 psi) tyre pressure in pneumatic tyres at all times may result in tyre and/or wheel failure.

- Regularly inspect your scooter's tyres for signs of wear.

WHEEL REPLACEMENT

If your scooter is equipped with pneumatic tyres and you have a flat tyre, you can have the tube replaced. If your scooter is equipped with a solid tyre insert, either the solid insert or the entire wheel must be replaced depending on model. Contact your authorised Pride Provider for information regarding replacement wheels for your scooter.



WARNING! Completely deflate pneumatic tyres before dismantling the rim or attempting repair.

WARNING! When changing a tyre, remove only the centre lug nut, then remove the tyre. If any further disassembly is required, deflate the tyre completely or it may explode.

EXTERIOR SURFACES

Bumpers, tyres, and trim can benefit from an occasional application of rubber or vinyl conditioner.



WARNING! Do not use a rubber or vinyl conditioner on the scooter's vinyl seat, floorboard, or tyre tread. They will become dangerously slippery.

CLEANING AND DISINFECTION

- Use a damp cloth and mild, non-abrasive cleanser to clean the plastic and metal parts of your scooter. Avoid using products that may scratch the surface of your scooter.
- If necessary, clean your product with an approved disinfectant. Make sure the disinfectant is safe for use on your product before application.



WARNING! Follow all safety instructions for the proper use of the disinfectant and/or cleaning agent before applying it to your product. Failure to comply may result in skin irritation or premature deterioration of upholstery and/or scooter finishes.

ABS PLASTIC SHROUDS

- The shrouds of the scooter are formed from durable ABS plastic and are coated with an advanced formula urethane paint.
- A light application of car wax will help the shrouds retain their high gloss.

X. CARE AND MAINTENANCE

WIRING HARNESSES

- Regularly check all wiring connections.
- Regularly check all wiring insulation, including the charger power lead, for wear or damage.
- Have your authorised Pride Provider repair or replace any damaged connector, connection, or insulation that you find before using your scooter again.



WARNING! Even though the scooter has passed the necessary testing requirements for ingress of liquids, you should keep electrical connections away from sources of dampness, including direct exposure to water or bodily fluids and incontinence. Check electrical components frequently for signs of corrosion and replace as necessary.

BATTERY TERMINAL CONNECTIONS

- Make certain that the terminal connections remain tight and uncorroded.
- The batteries must sit flat in the battery wells.
- The battery terminals should face the rear of the scooter.

MOTOR BRUSHES

The motor brushes are housed inside of the motor transaxle/assembly. They should be inspected periodically for wear by your authorised Pride Provider.

AXLE BEARINGS AND THE MOTOR/TRANSAXLE ASSEMBLY

You do not need to lubricate these items, as they are all prelubricated and sealed

CONSOLE, CHARGER AND ELECTRONIC CONTROLLER MODULE

- Keep these areas away from moisture.
- Before operating your scooter, allow any of these areas to dry thoroughly if they have been exposed to moisture.

FUSES

To replace a fuse:

1. Remove the fuse by pulling it straight out of its slot.
2. Examine the fuse to be sure it is blown. **See figures 25 and 25A.**
3. Insert a new fuse of the proper rating.



WARNING! The replacement fuse must exactly match the rating of the new fuse. Failure to use properly rated fuses may cause damage to the electrical system.

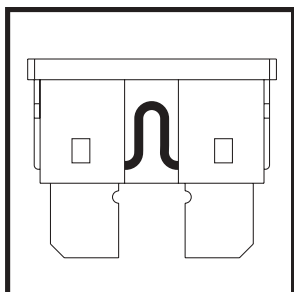

Figure 25. Working Fuse

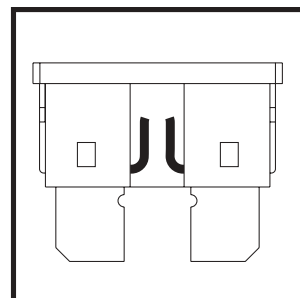

Figure 25A. Blown Fuse (Replace)

X. CARE AND MAINTENANCE

NYLON LOCK NUT REPLACEMENT

Any nylon insert lock nut removed during the periodic maintenance, assembly, or disassembly of the scooter must be replaced with a new nut. Nylon insert lock nuts should not be reused as it may cause damage to the nylon insert, resulting in a less secure fit. Replacement nylon insert lock nuts are available at local hardware stores or through your authorised Pride Provider.

STORING YOUR SCOOTER

If you plan on not using your scooter for an extended period of time, it is best to:

- Fully charge its batteries prior to storage.
- Disconnect both battery harnesses.
- Store your scooter in a warm, dry environment.
- Avoid storing your scooter where it will be exposed to temperature extremes.



WARNING! Always protect batteries from freezing temperatures and never charge a frozen battery.

Batteries that are regularly and deeply discharged, infrequently charged, stored in extreme temperatures, or stored without a full charge may be permanently damaged, causing unreliable performance and limited service life. It is recommended that you charge the scooter batteries periodically throughout periods of prolonged storage to ensure proper performance.

For prolonged storage, you may wish to place several boards under the frame of your scooter to raise it off of the ground. This takes the weight off the tyres and reduces the possibility of flat spots developing on the areas of the tyres contacting the ground.

DISPOSAL OF YOUR SCOOTER

Your scooter must be disposed of according to applicable local and national statutory regulations. Contact your local waste disposal agency or authorised Pride Provider for information on proper disposal of packaging, metal frame components, plastic components, electronics, and batteries.

XI. WARRANTY

TWO-YEAR LIMITED WARRANTY

Structural frame components, including: platform, fork, seat post, and frame welds.
Drivetrain, including: differential, motor, and brake.

ONE-YEAR LIMITED WARRANTY

Your Pride Scooter is fully guaranteed for twelve (12) months from the date of purchase against faults arising due to defects in manufacture or materials. This warranty does not detract from, but is in addition to your legal rights.

All electronic parts, including controllers and battery chargers, have a one (1) year warranty. Servicing to the controller or battery charger must be carried out by your authorised Pride Provider. Any attempt to open or dismantle these items renders the guarantee void on that item.

NOT COVERED UNDER WARRANTY

This guarantee does not extend to those items which may need replacement due to normal wear and tear (tyres, belts, bulbs, upholstery, plastic shrouds, motor brushes, fuses, and batteries) or damage to the product caused by misuse or accident for which Pride or its agent cannot be held responsible. This warranty does not include labour or service calls.

BATTERIES

Batteries are covered by a six (6) month warranty from the original manufacturer.

Gradual deterioration in performance due to being left in a discharged state, left in cold conditions for long periods of time or worn out through heavy use is not covered.

SERVICE CHECKS AND WARRANTY SERVICE

Warranty service can be performed by an authorised Pride Provider. Please contact your authorised Pride Provider for advice on the current cost affecting the service visit.

REPLACEMENT UNITS

The availability of replacement units is subject to the discretion of the Provider, not the manufacturer. For more information regarding replacement units, contact your authorised Pride Provider.



Pride

Mobility Products Australia Pty. Ltd.

***21 Healey Road
Dandenong, 3175
Victoria, Australia***

ACN # 088 609 661

www.pridemobility.com

I NFMANU3477