

GO-GO Ultra

Owner's Manual



The Ultimate In Style & Performance[®]

Pride

Mobility Products Australia Pty. Ltd.

21 Healey Road
Dandenong, 3175
Victoria, Australia

ACN # 088 609 661

www.pridemobility.com

SAFETY GUIDELINES

Please read and follow all instructions in this owner's manual before attempting to operate your scooter for the first time. If there is anything in this manual you do not understand, or if you require additional assistance for setup, contact your scooter specialist.

Using your Pride product safely depends upon your diligence in following the warnings, cautions, and instructions in this owner's manual. Pride is not responsible for injuries and/or damage resulting from any person's failure to follow the warnings, cautions, and instructions in this owner's manual. Pride is not responsible for injuries and/or damage resulting from any person's failure to exercise good judgement and/or common sense.

The symbols below are used throughout this owner's manual and/or on the scooter to identify warnings, cautions, and important information. It is very important for you to read and understand them completely.



WARNING! Failure to follow designated procedures can cause personal injury or component damage or malfunction (black symbol on yellow triangle with black border).



PROHIBITED! These actions should be prohibited. These actions should not be performed at any time or in any circumstances. Performing a prohibited action can cause injury to personnel and/or damage to equipment.



NOTE: Supplemental information that may be helpful to operate the equipment.



MANDATORY! These actions should be performed as specified. Failure to perform mandatory actions can cause injury to personnel and/or damage to equipment (white symbol on blue dot with white border).

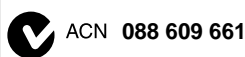

Copyright © 2004
Pride Mobility Products Australia Pty. Ltd.

INFMANU2714/Rev B/July 2004

CONTENTS

I. INTRODUCTION	4
II. SAFETY	6
III. SPECIFICATIONS	16
IV. YOUR SCOOTER	18
V. BATTERIES AND CHARGING	21
VI. OPERATION	25
VII. COMFORT ADJUSTMENTS	27
VIII. DISASSEMBLY AND ASSEMBLY	28
IX. BASIC TROUBLESHOOTING	31
X. CARE AND MAINTENANCE	33
XI. WARRANTY	34

I. INTRODUCTION

SAFETY

Welcome to Pride Mobility Products Australia Pty. Ltd. (Pride). The product you have purchased combines state-of-the-art components with **safety**, comfort, and styling in mind. We are confident that the design features will provide you with the conveniences you expect during your daily activities. Understanding how to **safely** operate and care for this product should bring you years of trouble free operations and service.

Read and follow all instructions, warnings, and notes in this manual and all other accompanying literature before attempting to operate this product for the first time. In addition, your **safety** depends upon you, as well as your provider or caretaker in using good judgement.

If there is any information in this manual which you do not understand, or if you require additional assistance for setup or operation, please contact your authorised Pride Provider. **Failure to follow the instructions, warnings, and notes in this manual and those located on your Pride product can result in personal injury or product damage and will void Pride's product warranty.**

INTERNET AND PRIVATE PURCHASES

If you purchased the scooter over the internet or from a previous owner and you have any questions about the safe use and/or maintenance of the product, contact an authorised Pride Provider.

PURCHASER'S AGREEMENT

By accepting delivery of this product, you promise that you will not change, alter, or modify this product or remove or render inoperable or unsafe any guards, shields, or other safety features of this product; fail, refuse, or neglect to install any retrofits kits from time to time provided by Pride to enhance or preserve the safe use of this product.

PRODUCT INFORMATION

This owner's manual is compiled from the latest specifications and product information available at the time of publication. We reserve the right to make changes as they become necessary. Any changes to our products may cause slight variations between the illustrations, explanations, and specifications in this manual and the product you have purchased.

I. INTRODUCTION

INFORMATION EXCHANGE

We want to hear your questions, comments, and suggestions about this manual. We would also like to hear about the safety and reliability of your new scooter, and about the service you received from your authorised Pride Provider.

Please notify us of any change of address, so we can keep you apprised of important information about safety, new products, and new options that can increase your ability to use and enjoy your scooter. Please feel free to contact us at the address below:

Pride Mobility Products Australia Pty. Ltd.
21 Healey Road
Dandenong, 3175
Victoria, Australia

My authorised Pride Provider:

Name: _____

Address: _____

Phone Number: _____

Purchase Date: _____



NOTE: If you ever lose or misplace your product registration card or your copy of this manual, contact us and we will be glad to send you a new one immediately.

II. SAFETY

PRODUCT SAFETY SYMBOLS

The symbols below are used on the scooter to identify warnings, mandatory actions, and prohibited actions. It is very important for you to read and understand them completely.



Pinch/Crush points created during assembly.



Corrosive chemicals are contained in batteries. Use only AGM or Gel-Cell batteries to reduce the risk of leakage or explosive conditions.



Do not use a cell phone, walkie/talkie, laptop, or other radio transmitter while operating.



Read and follow the information in the owner's manual.



Maximum weight capacity.



Unlocked and in freewheel mode.

Place unit on level ground and stand behind or to one side when changing from drive mode to freewheel mode or freewheel mode to drive mode.

Locked and in drive mode.

DWR1234L026 REV B

II. SAFETY

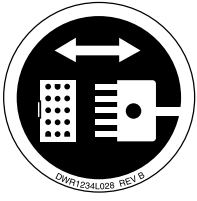

Front-to-rear plug orientation.



Do not remove anti-tip wheels.



Avoid exposure to rain, snow, ice, salt, or standing water whenever possible. Maintain and store in a clean and dry condition.



Removal of grounding prong can create electrical hazard. If necessary, properly install an approved 3-pronged adapter to an electrical outlet having 2-pronged plug access. Failure to heed could result in personal injury and/or property damage.

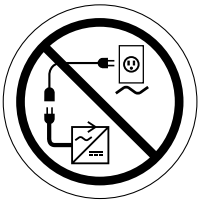

Prevent personal injury and equipment damage. Do not connect an extension lead to the AC/DC converter or the battery charger.



Use only AGM or Gel-Cell batteries.



Contact with tools can cause electrical shock.

II. SAFETY

GENERAL



WARNING! Do not operate your new scooter for the first time without completely reading and understanding this owner's manual.

Your scooter is a state-of-the-art life-enhancement device designed to increase mobility. Pride provides an extensive variety of products to best fit the individual needs of the scooter user. Please be aware that the final selection and purchasing decision regarding the type of scooter to be used is the responsibility of the scooter user who is capable of making such a decision.

There are certain situations, including some medical conditions, where the scooter user will need to practice operating the scooter in the presence of a trained attendant. A trained attendant can be defined as a family member or health care professional specially trained in assisting a scooter user in various daily living activities.

As you begin using your scooter during daily activities, you will probably encounter situations in which you will need some practice. Simply take your time and you will soon be in full and confident control as you maneuver through doorways, on and off of lifts, up and down ramps, and over moderate terrain.

Below are some precautions, tips, and other safety considerations that will help the user become accustomed to operating the scooter safely.

MODIFICATIONS

Pride has designed and engineered your scooter to provide maximum mobility and utility. A wide range of accessories is available from your authorised Pride Provider to further customise your scooter to better suit your needs and/or preferences. However, under no circumstances should you modify, add, remove, or disable any feature, part, or function of your scooter.



WARNING! Do not modify your scooter in any way not authorised by Pride. Unauthorised modifications may result in personal injury and/or damage to your scooter.

REMOVABLE PARTS



WARNING! Do not attempt to lift or move your scooter by any of its removable parts. Personal injury and damage to the scooter may result.

ELECTROMAGNETIC FIELDS

Your scooter's road performance features may be influenced by electromagnetic fields caused by cellular telephones or other radiating devices, such as hand-held radios, radio and television stations, wireless computer links, microwave sources, and paging transmitters.

II. SAFETY

PRE-RIDE SAFETY CHECK

Get to know the feel of your scooter and its capabilities. Pride recommends that you perform a safety check before each use to make sure your scooter operates smoothly and safely.

Perform the following inspections prior to using your scooter:

- Check for proper tyre inflation (if equipped with pneumatic tyres).
- Check all electrical connections. Make sure they are tight and not corroded.
- Check all harness connections. Make sure they are secured properly.
- Check the brakes.
- Check battery charge.

If you discover a problem, contact your authorised Pride Provider for assistance.

TYRE INFLATION

If your scooter is equipped with pneumatic tyres, you should check or have the air pressure checked regularly. Proper inflation pressures will prolong the life of your tyres and help ensure the smooth operation of your scooter.



WARNING! It is critically important that 2-2.4 bar (30-35 psi) tyre pressure be maintained in pneumatic tyres at all times. Do not underinflate or overinflate your tyres. Low pressure may result in loss of control, and overinflated tyres may burst. Failure to maintain 2-2.4 bar (30-35 psi) tyre pressure in pneumatic tyres at all times may result in tyre and/or wheel failure, causing serious personal injury and/or damage to your scooter.

WARNING! Inflate your scooter tyres from a regulated air source with an available pressure gauge. Inflating your tyres from an unregulated air source could overinflate them, resulting in a burst tyre and/or personal injury.

WEIGHT LIMITATIONS

Your scooter is rated for a maximum weight capacity. Refer to the specifications table for information.



WARNING! Exceeding the weight capacity voids your warranty and may result in personal injury and damage to your scooter. Pride will not be held responsible for injuries and/or property damage resulting from failure to observe weight limitations.

WARNING! Do not carry passengers on your scooter. Carrying passengers may result in personal injury and/or property damage.

INCLINE INFORMATION

More and more buildings have ramps with specified degrees of inclination, designed for easy and safe access. Some ramps may have turning switchbacks (180-degree turns) that require you to have good cornering skills on your scooter.

- Proceed with extreme caution as you approach the downgrade of a ramp or other incline.
- Take wide swings with your scooter around any tight corners. If you do that, the scooter's rear wheels will follow a wide arc, not cut the corner short, and not bump into or get hung up on any railing corners.
- When driving down a ramp, keep the scooter's speed adjustment set to the slowest speed setting to ensure a safely controlled descent.
- Avoid sudden stops and starts.

II. SAFETY

When climbing an incline, try to keep your scooter moving. If you must stop, start up again slowly, and then accelerate cautiously. When driving down an incline, do so by setting the speed adjustment dial to the slowest setting and driving in the forward direction only. If your scooter starts to move down the incline faster than you anticipated or desired, allow it to come to a complete stop by releasing the throttle control lever. Then push the throttle control lever forward slightly to ensure a safely controlled descent.

WARNING! When climbing an incline, do not zigzag or drive at an angle up the face of the incline. Drive your scooter straight up the incline. This greatly reduces the possibility of a tip or a fall. Always exercise extreme caution when negotiating an incline.

WARNING! Do not drive your scooter across the side of an incline or diagonally up or down an incline; do not stop, if possible, while driving up or down an incline.



WARNING! You should not travel up or down a potentially hazardous incline (i.e., areas covered with snow, ice, cut grass, or wet leaves).

WARNING! When on any sort of an incline or decline, never place the scooter in freewheel mode while seated on it or standing next to it.

WARNING! Even though your scooter is capable of climbing slopes greater than those illustrated in figure 1, do not, under any circumstances, exceed the incline guidelines or any other specifications presented in this manual. Doing so could cause instability in your scooter, resulting in personal injury and/or damage to your scooter.

Handicap public access ramps are not subject to government regulation in all countries, and therefore do not necessarily share the same standard degree of slope. Other inclines may be natural or, if man-made, not designed specifically for scooters. **Figure 1** illustrates your scooter's stability and its ability to climb grades under various weight loads and under controlled testing conditions.

These tests were conducted with the scooter's seat in the highest position and adjusted rearward on the seat base to its farthest rearward position. Use this information as a guideline. Your scooter's ability to travel up inclines is affected by your weight, your scooter's speed, your angle of approach to the incline, and your scooter setup.

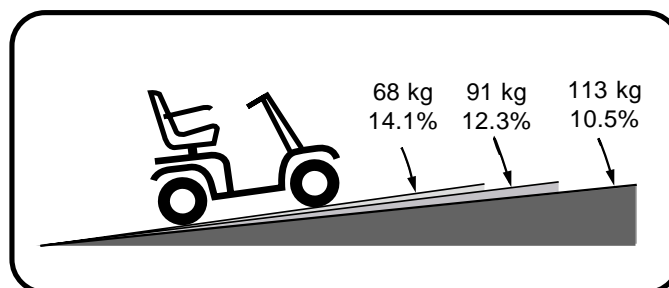

Figure 1. Maximum Recommended Incline Angles



WARNING! Any attempt to climb or descend a slope steeper than what is shown in figure 1 may put your scooter in an unstable position and cause it to tip, resulting in personal injury.

II. SAFETY

When you approach an incline, it is best to lean forward. See figures 2 and 2A. This shifts the centre of gravity of you and your scooter toward the front of the scooter for improved stability.

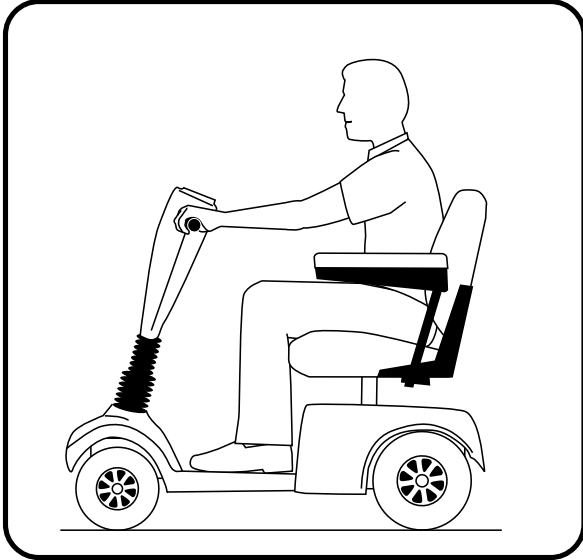

Figure 2. Normal Driving Position

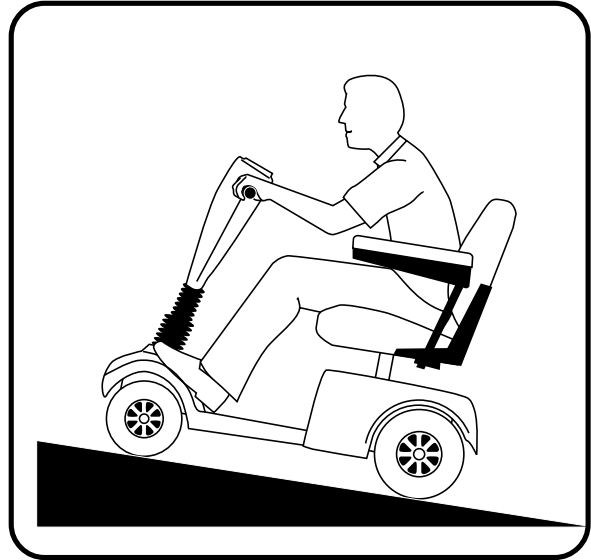

Figure 2A. Increased Stability Driving Position

CORNERING INFORMATION

Excessively high cornering speeds can create the possibility of tipping. Factors which affect the possibility of tipping include, but are not limited to, cornering speed, steering angle (how sharply you are turning), uneven road surfaces, inclined road surfaces, riding from an area of low traction to an area of high traction (such as passing from a grassy area to a paved area – especially at high speed while turning), and abrupt directional changes. High cornering speeds are not recommended. If you feel that you may tip over in a corner, reduce your speed and steering angle (i.e., lessen the sharpness of the turn) to prevent your scooter from tipping.



WARNING! When cornering sharply, reduce your speed. When using your scooter at higher speeds, do not corner sharply. This greatly reduces the possibility of a tip or fall. To avoid personal injury or property damage, always exercise common sense when cornering.

BRAKING INFORMATION

Your scooter is equipped with these powerful brake systems:

- Regenerative: Uses electricity to rapidly slow the vehicle when the throttle control lever returns to the centre/stop position.
- Disc Park Brake: Activates mechanically after regenerative braking slows the vehicle to near stop, or when power is removed from the system for any reason.

II. SAFETY

OUTDOOR DRIVING SURFACES

Your scooter is designed to provide optimum stability under normal driving conditions—dry, level surfaces composed of concrete, blacktop, or asphalt. However, Pride recognises that there will be times when you will encounter other surface types. For this reason, your scooter is designed to perform admirably on packed soil, grass, and gravel. Feel free to use your scooter safely on lawns and in park areas.

- Reduce your scooter's speed when driving on uneven terrain and/or soft surfaces.
- Avoid tall grass that can become tangled in the running gear.
- Avoid loosely packed gravel and sand.
- If you feel unsure about a driving surface, avoid that surface.

PUBLIC STREETS AND ROADWAYS



WARNING! Exercise extreme caution when operating the scooter on footpaths, pavements, bridleways, pedestrian areas, and roads. Failure to heed could result in serious injury and/or damage to your scooter.

STATIONARY OBSTACLES (STEPS, KERBS, ETC.)

WARNING! Do not drive near raised surfaces, unprotected ledges, and/or drop-offs (kerbs, porches, stairs, etc.).

WARNING! Do not attempt to have your scooter climb or descend an obstacle that is inordinately high. Serious personal injury and/or damage may result.



WARNING! Do not attempt to have your scooter proceed rearward down any step, kerb, or other obstacle. This may cause the scooter to tip and cause personal injury.

WARNING! Be sure your scooter is traveling perpendicular to any kerb you may be required to ascend or descend. See figures 3 and 3A.

WARNING! Do not attempt to negotiate a kerb that has a height greater than 5 cm.

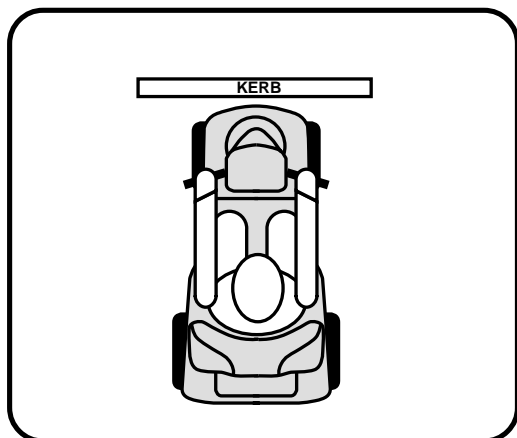

Figure 3. Correct Kerb Approach

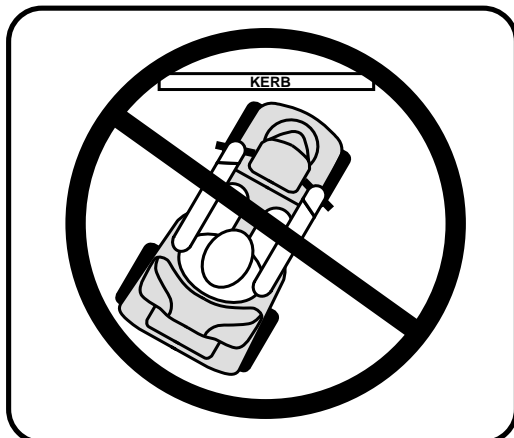

Figure 3A. Incorrect Kerb Approach

II. SAFETY

INCLEMENT WEATHER PRECAUTIONS

WARNING! Pride recommends that you do not operate your scooter in icy or slippery conditions or on salted surfaces (i.e., walks or roads). Such use may result in an accident, personal injury, or adversely affect the performance and safety of your scooter.



WARNING! Do not operate or store your scooter where it may be exposed to inclement weather conditions such as rain, snow, mist, and below freezing temperatures (such as storage on an outside car/van lift). Attempting to operate the scooter in such conditions can damage the electronics and potentially result in loss of control.

FREEWHEEL MODE

Your scooter is equipped with a manual freewheel lever that, when pushed forward, allows the scooter to be pushed. For more information about how to place your scooter into and out of freewheel mode, see IV. “Your Scooter.”

WARNING! When your scooter is in freewheel mode, the braking system is disengaged.



- **Disengage the drive motors only on a level surface.**
- **Ensure the key is removed from the key switch.**
- **Stand behind the scooter to engage or disengage freewheel mode. Never sit on a scooter to do this.**
- **After you have finished pushing your scooter, always return it to the drive mode to lock the brakes.**

Failure to heed the above could result in personal injury and/or damage to your scooter.

An added feature built into the scooter is “push-too-fast” protection which safeguards the scooter against gaining excessive speed while in freewheel mode.

“Push-too-fast” operates differently depending on which of two conditions exists:

- If the key is removed from the key switch while in freewheel mode, the scooter’s controller activates regenerative braking when the scooter is pushed faster than a maximum threshold which has been preprogrammed. In this case, the controller is acting as a speed governor.
- If the key is inserted into the key switch while in freewheel mode, you will encounter considerable resistance at any speed. This prevents the scooter from gaining unwanted momentum should the manual freewheel lever inadvertently be released while driving the scooter.

STAIRS AND ESCALATORS

Scooters are not designed to travel up or down stairs or escalators. Always use a lift.



WARNING! Do not use your scooter to negotiate steps or escalators. You may cause injury to yourself and to others and/or damage your scooter.

DOORS

- Determine if the door opens toward or away from you.
- Use your hand to turn the knob or push the handle or push-bar.
- Drive your scooter gently and slowly forward to push the door open. Or drive your scooter gently and slowly rearward to pull the door open.

II. SAFETY

LIFTS

Modern lifts have a door edge safety mechanism that, when pushed, reopens the door(s).

- If you are in the doorway of a lift when the door(s) begin to close, push on the rubber door edge or allow the rubber door edge to contact the scooter and the door will reopen.
- Use care that pocketbooks, packages, or scooter accessories do not become caught in lift doors.

LIFT/ELEVATION PRODUCTS

If you will be traveling with your scooter, you may find it necessary to use a lift/elevation product to aid in transportation. Pride recommends that you closely review the instructions, specifications, and safety information set forth by the manufacturer of the lift/elevation product before using that product.

BATTERIES

In addition to following the warnings below, be sure to comply with all other battery handling information.

WARNING! Scooter batteries are heavy (refer to specifications table). Lifting weight beyond your capacity could result in personal injury. If necessary, get someone physically able to lift the scooter batteries for you.

WARNING! Battery posts, terminals, and related accessories contain lead and lead compounds. Wash hands after handling.



WARNING! Always protect the batteries from freezing and never charge a frozen battery. Charging a frozen battery may result in personal injury and/or damage to the battery.

WARNING! RED (+) cables must be connected to positive (+) battery terminals/posts. BLACK (-) cables must be connected to negative (-) battery terminals/posts. Failure to connect your battery cables and harnesses in the proper manner may result in personal injury and/or damage to your scooter. REPLACE cables immediately if damaged.

BATTERY DISPOSAL AND RECYCLING

If you encounter a damaged or cracked battery, immediately enclose it in a plastic bag and call your authorised Pride Provider for instructions on disposal. Your authorised Pride Provider will also have the necessary information on battery recycling, which is our recommended course of action.

MOTOR VEHICLE TRANSPORT

Currently, there are no standards approved for tie-down systems in a moving vehicle of any type to transport a person while seated in a scooter.

Although your scooter may be equipped with a positioning belt, this belt is not designed to provide proper restraint during motor vehicle transport. Anyone traveling in a motor vehicle should be properly secured in the motor vehicle seat with safety belts fastened securely.

WARNING! Do not sit on your scooter while it is in a moving vehicle. Personal injury and/or property damage may result.



WARNING! Always be sure your scooter and its batteries are properly secured when it is being transported. Failure to do so may result in personal injury and/or damage to your scooter.

II. SAFETY

PREVENTING UNINTENDED MOVEMENT



WARNING! If you anticipate being seated in a stationary position for an extended period of time, turn off the power. This will prevent unexpected motion from inadvertent throttle control lever contact. Failure to do so may result in personal injury.

GETTING ONTO AND OFF OF YOUR SCOOTER

Getting onto and off of your scooter requires a good sense of balance. Please observe the following safety tips when getting onto and off of your scooter:

- Remove the key from the key switch when getting onto and off of your scooter.
- Ensure that your scooter is not in freewheel mode. See IV. “Your Scooter.”
- Make certain that the seat is locked into place.

WARNING! When driving on level ground, position yourself as far back as possible in the scooter seat to prevent the scooter from tipping and causing injury.



WARNING! Avoid using your armrests for weight bearing purposes. Such use may cause the scooter to tip and cause personal injury.

WARNING! Avoid putting all of your weight on the floorboard. Such use may cause the scooter to tip and cause personal injury.

REACHING AND BENDING

Avoid reaching or bending while driving your scooter. When reaching, bending, or leaning while seated on your scooter, it is important to maintain a stable centre of gravity and keep the scooter from tipping. Pride recommends that the scooter user determine his/her personal limitations.



WARNING! Do not bend, lean, or reach for objects if you have to pick them up from the floor by reaching down between your knees. Movements such as these may change your centre of gravity and the weight distribution of the scooter and cause your scooter to tip, possibly resulting in personal injury. Keep your hands away from the tyres when driving.

POSITIONING BELTS



WARNING! If you require a positioning belt to safely operate your scooter, make sure it is fastened securely. Serious personal injury may result if you fall from the scooter.

PRESCRIPTION DRUGS/PHYSICAL LIMITATIONS

The scooter user must exercise care and common sense when operating his/her scooter. This includes awareness of safety issues when taking prescribed or over-the-counter drugs or when the user has specific physical limitations.



WARNING! Consult your physician if you are taking prescribed or over-the-counter medication or if you have certain physical limitations. Some medications and limitations may impair your ability to operate your scooter in a safe manner.

ALCOHOL

The scooter user must exercise care and common sense when operating his/her scooter. This includes awareness of safety issues while under the influence of alcohol.



WARNING! Do not operate your scooter while you are under the influence of alcohol, as this may impair your ability to drive safely.

III. SPECIFICATIONS

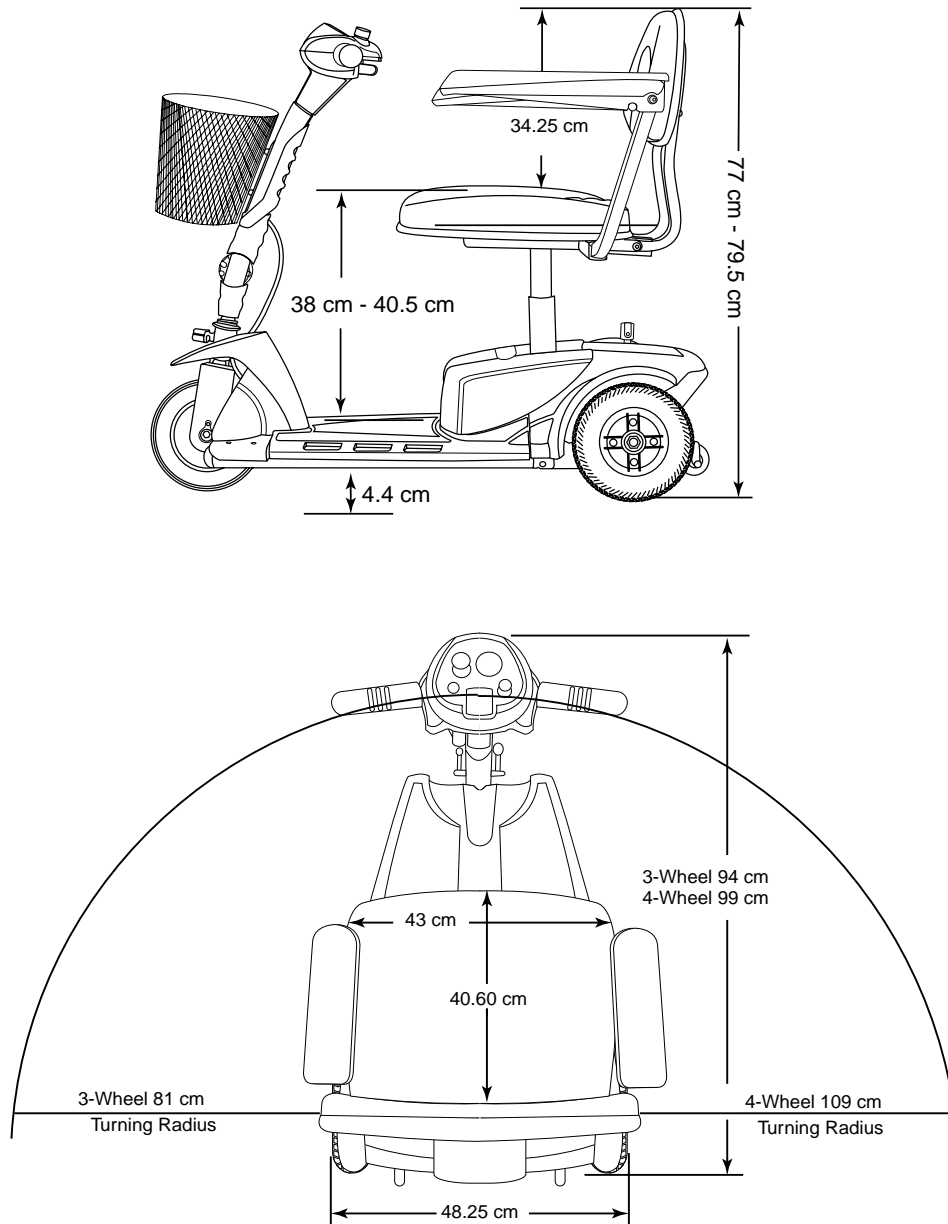

Figure 4. Go-Go Ultra Dimensions



Figure 4A. Go-Go Ultra Front And Rear Tyre Dimensions

III. SPECIFICATIONS

Model Numbers	3-Wheel: SC40UAU 4-Wheel: SC44UAU
Class of Use	A
Maximum Safe Slope	See figure 1.
Colours	Red, Blue
Overall Length	3-Wheel: 94 cm 4-Wheel: 99 cm
Overall Width	48.25 cm
Total Weight Without Batteries	3-Wheel: 30 kg 4-Wheel: 34.5 kg
Heaviest Piece When Disassembled	Rear section: 14 kg
Turning Radius	3-Wheel: 81 cm 4-Wheel: 109 cm
Speed (Maximum)	Variable up to 6.5 km/h
Range Per Charge*	(With 12 AH batteries) Up to 16 km
Ground Clearance	4.4 cm
Weight Capacity	113 kg
Seating	Standard: Type: Foldable Material: Black Vinyl Dimensions: 43 cm width 40.60 cm depth (usable) 34.25 cm height (usable)
Drive System	Rear-wheel drive, sealed transaxle, 24 volt DC motor
Dual Braking System	Electronic, regenerative, and electromechanical
Tyres	Type: solid; front: 5 cm x 19 cm, rear: 8 cm x 19 cm
Battery Requirements	Type: Two 12 volt, deep cycle, AGM or Gel-Cell Size: 12 AH Weight: Battery pack weighs 9 kg
Battery Charger	Off-board

* *Varies with user weight, terrain type, battery charge, battery condition, and tyre condition.*

IV. YOUR SCOOTER

TILLER CONSOLE

The tiller console houses all controls needed to drive your scooter, including the key switch, throttle control lever, horn button, speed adjustment dial, and the battery condition metre. See figure 5.



WARNING! Do not expose the tiller console to moisture. In the event that the tiller console does become exposed to moisture, do not attempt to operate your scooter until the tiller console has dried thoroughly.

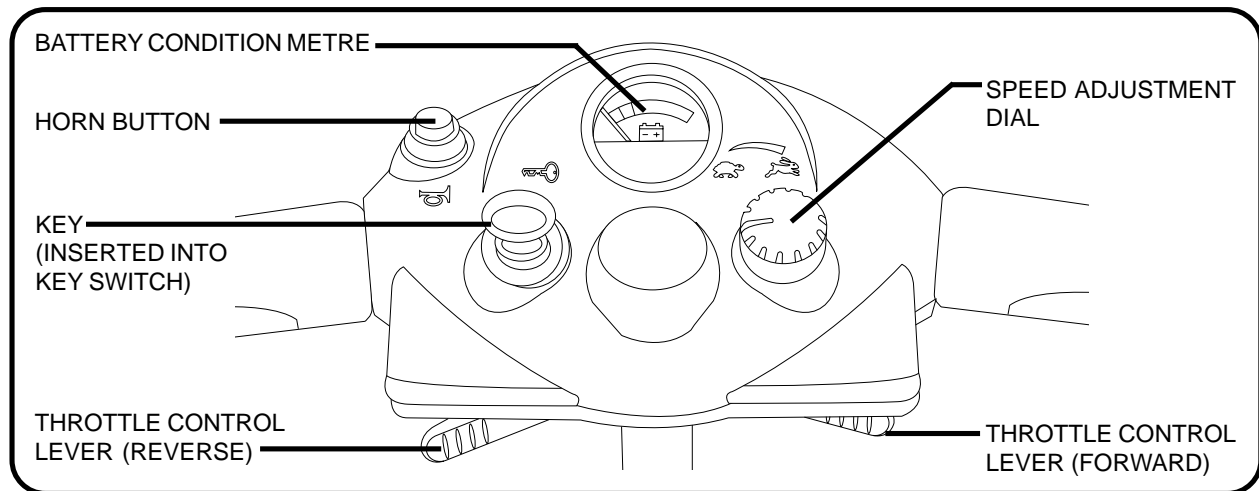

Figure 5. Tiller Console

Key Switch

- Fully insert the key into the key switch to power up (turn on) your scooter.
- Remove the key from the key switch to power down (turn off) your scooter.

Throttle Control Lever

This lever allows you to control the forward speed and the reverse speed of your scooter up to the maximum speed you preset with the speed adjustment dial.

- Place your right hand on the right handgrip and your left hand on the left handgrip.
- Use your right thumb to push the right side of the lever to disengage your scooter's brakes and move forward.
- Release the lever and allow your scooter to come to a complete stop before pushing the other side of the lever to move in reverse.
- When the throttle is completely released, it automatically returns to the centre "stop" position and engages your scooter's brakes.

Horn Button

The key must be fully inserted into the key switch for the horn to be operational.

- This button activates a warning horn.
- Do not hesitate to use the warning horn when doing so may prevent accident or injury.

Speed Adjustment Dial

This dial allows you to preselect and limit your scooter's top speed.

- The image of the tortoise represents the slowest speed setting.
- The image of the hare represents the fastest speed setting.

Battery Condition Metre

When the key is fully inserted into the key switch, this metre indicates approximate battery strength. For further information on the battery condition metre, see V. "Batteries and Charging."

IV. YOUR SCOOTER

REAR SECTION

The manual freewheel lever, anti-tip wheels, and motor/transaxle assembly are located on the rear section of your scooter. See figure 6.



WARNING! Before placing your scooter into or taking it out of freewheel mode, remove the key from the key switch. Never sit on a scooter when it is in freewheel mode. Never put a scooter in freewheel mode on any incline.

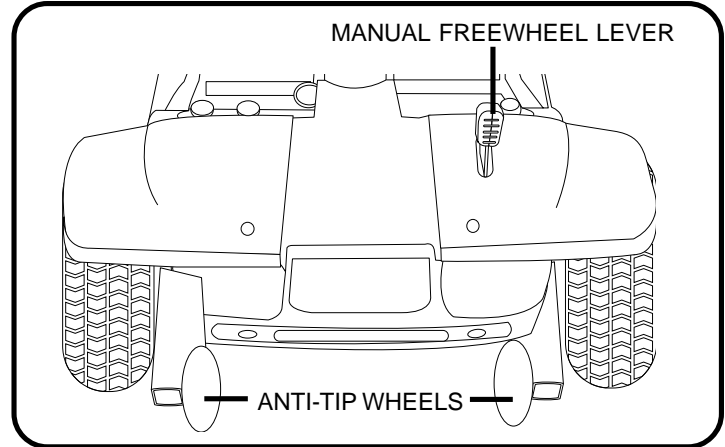

Figure 6. Rear Section

Manual Freewheel Lever

Whenever you need or want to push your scooter for short distances, you can put it in freewheel mode.

- The manual freewheel lever is located at the top right of the rear section.
- Push forward on the manual freewheel lever to disable the drive system and the brake system.
- You may now push your scooter.
- Push the manual freewheel lever rearward to reengage the drive and the brake systems; this takes your scooter out of freewheel mode.

WARNING! When your scooter is in freewheel mode, the braking system is disengaged.



- Disengage the drive motors only on a level surface.
- Ensure the key is removed from the key switch.
- Stand behind the scooter to engage or disengage freewheel mode. Never sit on a scooter to do this.
- After you have finished pushing your scooter, always return it to the drive mode to lock the brakes.

Failure to heed the above could result in personal injury and/or damage to your scooter.

Anti-Tip Wheels

The anti-tip wheels are an integral and important safety feature of your scooter. Do not, under any circumstances, remove the anti-tip wheels from your scooter.



WARNING! Do not remove the anti-tip wheels or modify your scooter in any way that is not authorised by Pride.

Motor/Transaxle Assembly (Not Shown)

The motor/transaxle assembly is an electromechanical unit that converts electrical energy from your scooter's batteries into the controlled mechanical energy that drives the scooter's wheels.

IV. YOUR SCOOTER

BATTERY PACK

The scooter is equipped with an innovative, easy to remove battery pack. A handle on the top of the battery pack makes it easy to lift the pack off of the scooter with one hand. The battery pack contains two 12 volt, 12 AH batteries; the charger power lead receptacle; and the main circuit breaker (reset button). See figure 7.

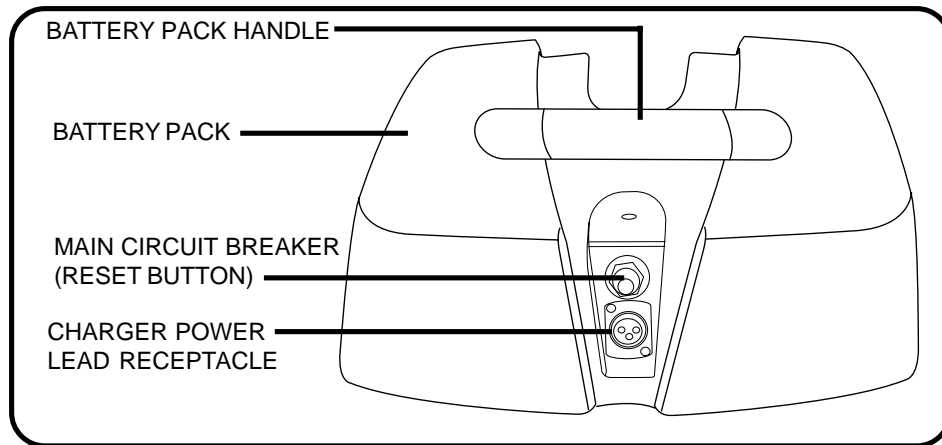

Figure 7. Battery Pack

Charger Power Lead Receptacle

The scooter's 3-pin off-board charger lead plugs into this receptacle.

Main Circuit Breaker (Reset Button)

When the voltage in your scooter's batteries becomes low or the scooter is heavily strained because of excessive loads or steep inclines, the main circuit breaker may trip to protect the motor and electronics from damage.

- The main circuit breaker reset button pops out when the breaker trips.
- When the breaker trips, the entire electrical system of your scooter shuts down.
- Allow a minute or two for your scooter's electronics to "rest."
- Push in the reset button to reset the main circuit breaker.
- If the main circuit breaker trips frequently, you may need to charge your batteries more often. You may also need to have your authorised Pride Provider perform a load test on your scooter's batteries.
- If the main circuit breaker trips repeatedly, see your authorised Pride Provider for service.

OFF-BOARD BATTERY CHARGER

The off-board battery charger, when plugged into the charger power lead receptacle (located on the battery pack) and a standard wall outlet, charges the scooter's batteries. See figure 7A.

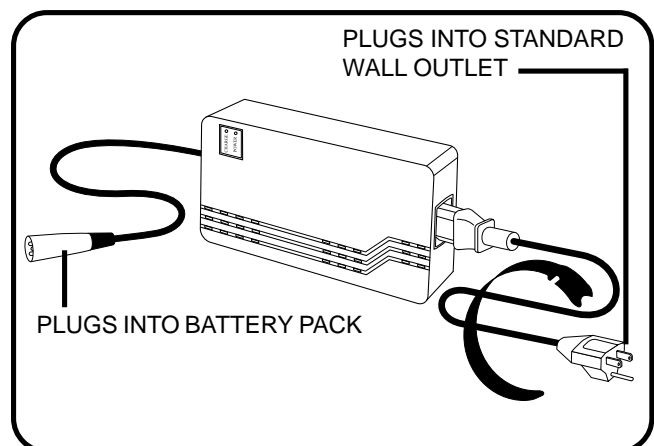

Figure 7A. Off-Board Battery Charger

V. BATTERIES AND CHARGING

Your scooter is equipped with two sealed, maintenance free, 12 AH batteries. Fully charge the batteries prior to using your scooter for the first time. Keeping the batteries fully charged will keep your scooter running smoothly.

READING YOUR BATTERY VOLTAGE

The battery condition metre on the tiller console uses a colour code to indicate the approximate strength of your batteries. Green indicates fully charged batteries, yellow a draining charge, and red indicates that an immediate re-charge is necessary. **See figure 8.** To ensure the highest accuracy, the battery condition metre should be checked while operating your scooter at full speed on a dry, level surface.

To check the battery strength during charging, you must first unplug the charger power lead and power up your scooter by inserting the key into the key switch.

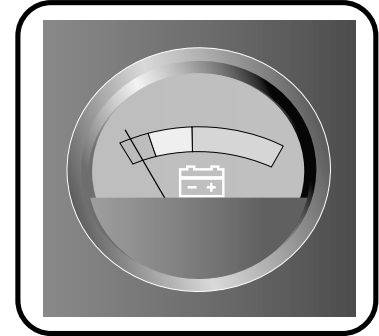

Figure 8. Battery Condition Metre

CHARGING YOUR BATTERIES



WARNING! Never use an extension lead to plug in your battery charger. Plug the charger directly into a properly wired standard wall outlet.



WARNING! Removal of the grounding prong can create an electrical hazard. If necessary, properly install an approved 3-prong adapter to an electrical outlet having 2-pronged plug access. Failure to heed could result in personal injury and/or property damage.

The scooter's battery pack can be charged on or off the scooter.

Follow these easy steps to charge your batteries safely:

1. Position your scooter close to a standard wall outlet.
2. Remove the key from the key switch.
3. Make certain that the manual freewheel lever is in the drive (rearward) position.
4. Remove the charger power lead receptacle cover from the charger power lead receptacle and plug the 3-pin off-board charger power lead into the receptacle.
5. Extend the charger power lead from the off-board battery charger and plug it into the wall outlet. It is recommended that you charge your batteries for 8 to 14 hours.
6. When the batteries are fully charged, unplug the off-board charger power lead from the wall outlet and then from the charger power lead receptacle.
7. Replace the charger power lead receptacle cover.



NOTE: There is a charger inhibit function on your scooter. The scooter will not run and the battery condition metre will not operate if the charger power lead is not disconnected from the battery pack.

V. BATTERIES AND CHARGING

FREQUENTLY ASKED QUESTIONS (FAQS)

How does the charger work?

When your scooter's battery voltage is low, the charger works harder, sending more electrical current to the batteries to bring up their charge. As the voltage approaches full charge, the charger sends less and less electrical current to the batteries. When the batteries are fully charged, the current sent by the charger is at nearly zero amperage. Therefore, when the charger is plugged in, it maintains the charge on your scooter's batteries, but does not overcharge them. We do not recommend that you charge your scooter's batteries for more than 24 consecutive hours.

What if my scooter's batteries won't charge?

Ensure that both ends of the charger power lead are inserted fully.

How often must I charge the batteries?

Two major factors must be considered when deciding how often to charge your scooter's batteries:

- All day scooter use on a daily basis.
- Infrequent or sporadic scooter use.

With these considerations in mind, you can determine how often and for how long you should charge your scooter's batteries. We designed the off-board charger so that it will not overcharge your scooter's batteries. However, you may encounter some problems if you do not charge your batteries often enough and if you do not charge them on a regular basis. Following the guidelines below will provide safe and reliable battery operation and charging.

- If you use your scooter daily, charge its batteries as soon as you finish using it for the day. We recommend that you charge your scooter's batteries for 8 to 14 hours after daily use.
- If you use your scooter once a week or less, charge its batteries at least once a week for 12 to 14 hours at a time.
- Keep your scooter's batteries fully charged.
- Avoid deeply discharging your scooter's batteries.
- Do not charge your scooter's batteries for more than 24 consecutive hours.

How can I get maximum range or distance per charge?

Rarely will you have ideal driving conditions—smooth, flat, hard driving surfaces with no wind or curves. Often you will face hills, foot path cracks, uneven and loosely packed surfaces, curves, and wind, all of which affect the distance or running time per battery charge. Below are a few suggestions for obtaining the maximum range per battery charge.

- Fully charge your scooter's batteries prior to use.
- Plan your route to avoid as many hills, cracked, broken, or soft surfaces as possible.
- Limit your baggage weight to essential items.
- Try to maintain an even speed while your scooter is in motion.
- Avoid stop-and-go driving.

What about public transportation?

If you intend to use public transportation with your scooter, you must contact the transportation provider in advance to determine their specific requirements.

V. BATTERIES AND CHARGING

What type and size battery should I use?

Your scooter comes equipped with two deep-cycle batteries that are sealed and maintenance free. Both AGM and Gel-Cell are deep-cycle batteries that are similar in performance. Do not use wet-cell batteries, which have removable caps.



WARNING! Corrosive chemicals are contained in batteries. Use only AGM or Gel-Cell batteries to reduce the risk of leakage or explosive conditions.

Use these specifications to reorder deep-cycle batteries from your authorised Pride Provider:

Battery Specifications	
Type:	Deep-cycle (AGM or Gel-Cell)
Voltage:	12 volts each
Size:	12 AH

Why do my new batteries seem weak?

Deep-cycle batteries employ a different chemical technology than that used in car batteries, nickel-cadmium batteries (nicads), or in other common battery types. Deep-cycle batteries are specifically designed to provide power, drain down their charge, and then accept a relatively quick recharge.

We work closely with our battery manufacturer to provide batteries that best suit your scooter's specific electrical demands. Fresh batteries arrive daily at Pride and are shipped fully charged to our customers. During shipping, the batteries may encounter temperature extremes that may influence their initial performance. Heat diminishes the charge on the battery; cold slows the available power and extends the time needed to recharge the battery.

It may take a few days for the temperature of your scooter's batteries to stabilise and adjust to their new room or ambient temperature.



WARNING! If your scooter's batteries become frozen, do not attempt to charge them. Cold or frozen batteries should be allowed to warm up for several days prior to recharging.

It takes a few charging cycles (partial draining followed by full recharging) to establish the critical chemical balance that is essential to a deep-cycle battery's peak performance and long life. Follow these steps to properly break-in your scooter's new batteries for maximum efficiency and service life.

1. Fully recharge any new battery prior to its initial use. This charging cycle brings the battery up to about 88% of its peak performance level.
2. Operate your new scooter in familiar and safe areas. Drive slowly at first, and do not travel too far from your home or familiar surroundings until you have become accustomed to your scooter's controls.
3. Fully recharge the batteries. They should be at over 90% of their peak performance level.
4. Operate your scooter again.
5. Fully recharge the batteries again.
6. After four or five charging cycles, the batteries are able to receive a charge of 100% of their peak performance level and are able to last for an extended period of time.

V. BATTERIES AND CHARGING

How can I ensure maximum battery life?

Fully charged deep-cycle batteries provide reliable performance and extended battery life. Keep your scooter's batteries fully charged whenever possible. Batteries that are regularly and deeply discharged, infrequently charged, or stored without a full charge may be permanently damaged, causing unreliable performance and limited service life.

REPLACING YOUR SCOOTER'S BATTERIES



WARNING! Battery posts, terminals, and related accessories contain lead and lead compounds. Wash hands after handling.

Battery Removal

1. Remove the battery pack from the scooter by grasping the battery pack handle and lifting up.
2. Turn the pack upside down.
3. Remove all screws that hold the battery pack halves together.
4. Flip the battery pack back over so the handle is up and remove the lid.
5. Remove the red (+) positive and black (-) negative battery leads from the battery by pulling them straight away from the battery terminals.
6. Remove the battery or batteries to be replaced.

Battery Replacement

1. Put the new battery or batteries back into the battery pack (battery terminals up).
2. Reconnect the two (2) battery leads to the battery terminals.
 - Red lead to (+) positive terminal.
 - Black lead to (-) negative terminal.
3. Replace the lid and carefully flip the battery pack over so the handle is down.
4. Replace and tighten all the screws that hold the battery pack halves together.
5. Reinstall the battery pack back onto the scooter.

BATTERY DISPOSAL AND RECYCLING

If you encounter a damaged or cracked battery, immediately enclose it in a plastic bag and call your authorised Pride Provider for instructions on disposal. Your authorised Pride Provider will also have the necessary information on battery recycling, which is our recommended course of action.

VI. OPERATION

BEFORE GETTING ONTO YOUR SCOOTER

- Have you fully charged the batteries? See V. “Batteries and Charging.”
- Is the manual freewheel lever in the drive (rearward) position? Never leave the manual freewheel lever pushed forward unless you are manually pushing your scooter.
- **Is the tiller lock knob in the unlocked position?** See VIII. “Disassembly and Assembly.”

GETTING ONTO YOUR SCOOTER



WARNING! Never attempt to get onto or off of your scooter without first removing the key from the key switch. This will prevent the scooter from moving if accidental throttle control lever contact is made.

1. Make certain that the key is removed from the key switch.
2. Disengage the seat lock lever and rotate the seat so it faces you.
3. Make certain that the seat is locked securely in position.
4. Position yourself comfortably and securely in the seat and rotate the seat forward.
5. Make certain that your feet are safely on the floorboard.

PRE-RIDE ADJUSTMENTS AND CHECKS

- Are you positioned comfortably in the seat?
- Is the seat at the proper height?
- Is the seat securely in place?
- Is the tiller at a comfortable setting and locked securely in place? See VII. “Comfort Adjustments.”
- Is the key fully inserted into the key switch? See IV. “Your Scooter.”
- Does the scooter’s horn work properly?
- Is your proposed path clear of people, pets, and obstacles?
- Have you planned your route to avoid adverse terrain and as many inclines as possible?

OPERATING YOUR SCOOTER

WARNING! The following can adversely affect steering and stability while operating your scooter:



- **Holding onto or attaching a leash to walk your pet.**
- **Carrying passengers (including pets).**
- **Hanging any article from the tiller.**
- **Towing or being pushed by another motorised vehicle.**

Such practices could cause loss of control and/or tipping, resulting in personal injury and/or damage to your scooter.

Keep both hands on the tiller and your feet on the floorboard at all times while operating your scooter. This driving position gives you the most control over your vehicle.

- Set the speed adjustment dial to your desired speed.
- Press your thumb against the appropriate side of the throttle control lever.
- The electromechanical disc park brake automatically disengages and the scooter accelerates smoothly to the speed you preselected with the speed adjustment dial.
- Pull on the left handgrip to steer your scooter to the left.
- Pull on the right handgrip to steer your scooter to the right.

VI. OPERATION

- Move the tiller to the centre position to drive straight ahead.
- Release the throttle control lever to decelerate and come to a complete stop.
- The electromechanical disc park brake automatically engages when your scooter comes to a stop.



NOTE: Your scooter's reverse speed is slower than that of the forward speed you preset with the speed adjustment dial.

GETTING OFF OF YOUR SCOOTER

1. Bring your scooter to a complete stop.
2. Remove the key from the key switch.
3. Rotate the seat to either side of the scooter and carefully and safely get out of the seat.

VII. COMFORT ADJUSTMENTS



WARNING! Remove the key from the key switch before adjusting the tiller or the seat. Never attempt to adjust the tiller or the seat while the scooter is in motion.

TILLER ANGLE ADJUSTMENT

Your scooter is equipped with an adjustable pivoting tiller that you can position to maximise your ergonomic comfort.

1. Turn the tiller adjustment knob anticlockwise to loosen the tiller. See figure 9.
2. Move the tiller to a comfortable position.
3. Turn the tiller adjustment knob clockwise to secure the tiller in position.



NOTE: In order to lower the tiller to the scooter deck, you must first remove the seat.

SEAT ROTATION

The seat lock lever is located at the bottom of the right side of the seat. The lever allows you to lock the seat into one of four positions: forward, rearward, left, and right.

1. Pull up on the seat lock lever to unlock the seat.
2. Rotate the seat to the desired position.
3. Release the seat lock lever to lock the seat securely in place.

SEAT HEIGHT ADJUSTMENT

The seat can be repositioned to different heights. See figure 10.

1. Remove the seat from your scooter.
2. Use the attached ring to pull and remove the detent pin from the lower seat post.
3. Raise or lower the upper seat post to the desired seat height.
4. While holding the upper seat post at that height, align the adjustment holes of the upper and lower seat posts.
5. Fully insert the detent pin.
6. Reinstall the seat.

ARMREST WIDTH ADJUSTMENT

The armrest width can be adjusted inward or outward.

1. Loosen the armrest adjustment knobs at the back of the seat frame.
2. Slide the armrests in or out to the desired width.
3. Tighten the armrest adjustment knobs as required.

The armrests can also pivot upward to aid in getting onto and off of your scooter.

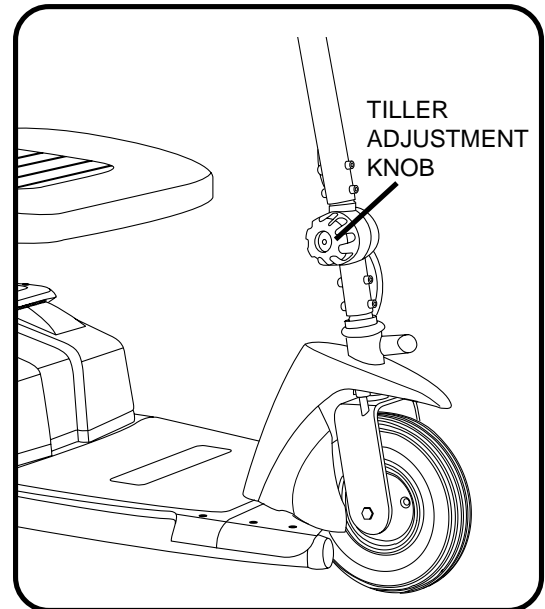

Figure 9. Tiller Adjustment

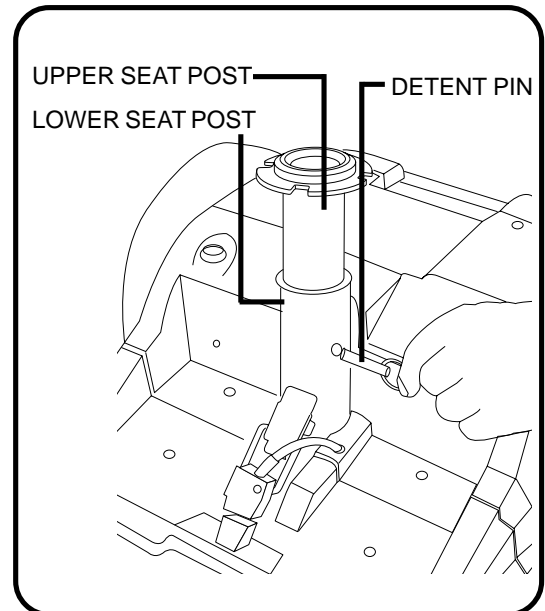

Figure 10. Seat Height Adjustment

VIII. DISASSEMBLY AND ASSEMBLY

DISASSEMBLY

No tools are required to disassemble or assemble your scooter. Always disassemble or assemble your scooter on a level, dry surface with sufficient room for you to work. Keep in mind that the disassembled sections of a scooter take up more floor space than the assembled scooter.

You can disassemble the scooter into four pieces: the seat, the front section, the rear section, and the battery pack. See figure 11.

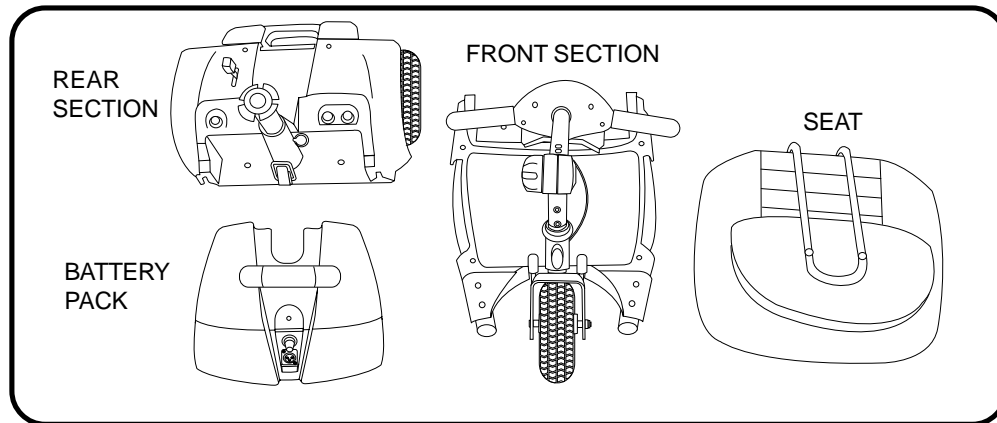

Figure 11. Disassembled Scooter



WARNING! Lifting weight beyond your physical capability may result in personal injury. Ask for assistance when necessary before disassembling your scooter.



WARNING! Before disassembling the scooter, remove the key and place the manual freewheel lever in the drive (rearward) position.

1. From the unlocked position (see figure 12), lock the front wheel by pushing the tiller lock knob in and turning it clockwise 90°. See figure 12A.

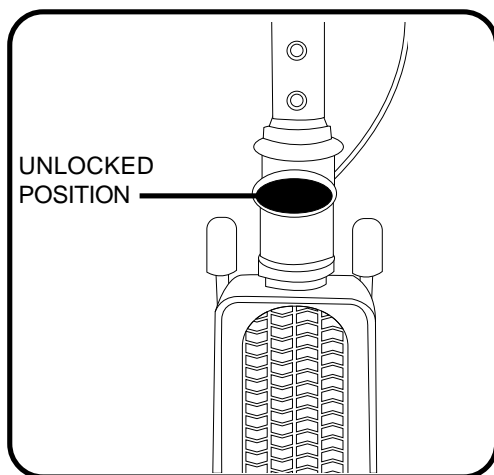

Figure 12. Tiller Lock Knob (Unlocked)

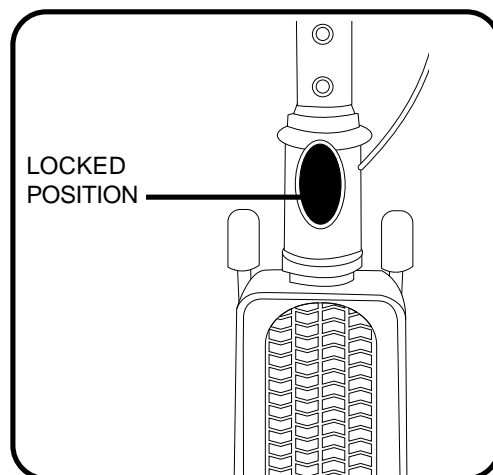

Figure 12A. Tiller Lock Knob (Locked)

VIII. DISASSEMBLY AND ASSEMBLY

2. Remove the seat by lifting it straight up and off of the scooter.
3. Remove the battery pack. Use the battery pack handle to pull the battery pack up and away from the scooter. **See figure 13.**
4. Unplug the front-to-rear harness. **See figure 14.**

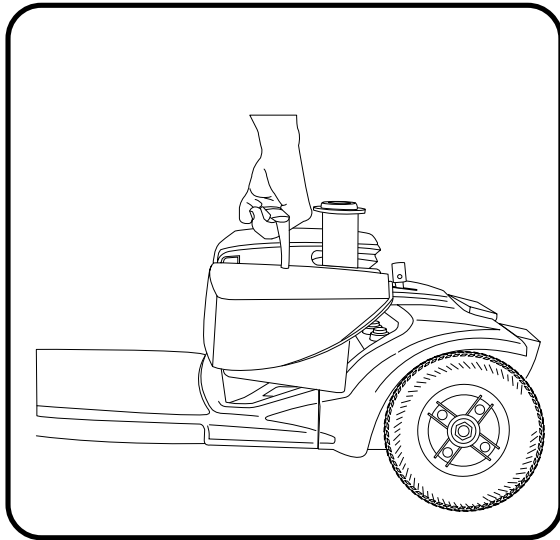

Figure 13. Lifting The Battery Pack

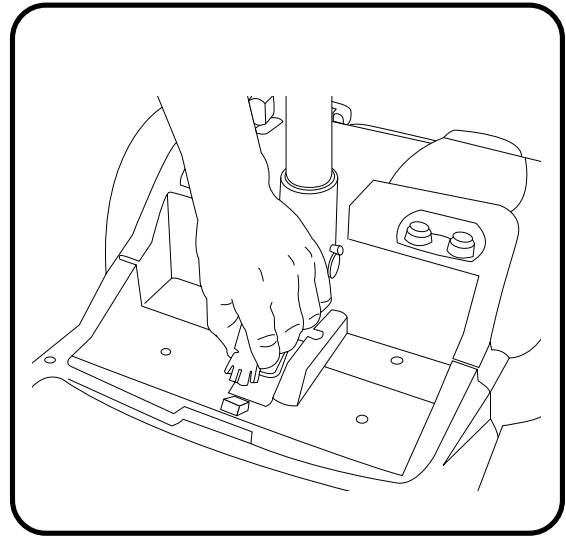

Figure 14. Front-To-Rear Harness

Toggle Latch Release

1. Push in the toggle latch release button while pulling back on the toggle latch. **See figure 15.**
2. Rotate the toggle latch buckle over the top of the toggle latch until it snaps into its retainer. **See figure 15A.**
3. Loosen the tiller adjustment knob and lower the tiller until it is horizontal to the scooter floorboard.
4. Fully tighten the tiller adjustment knob.

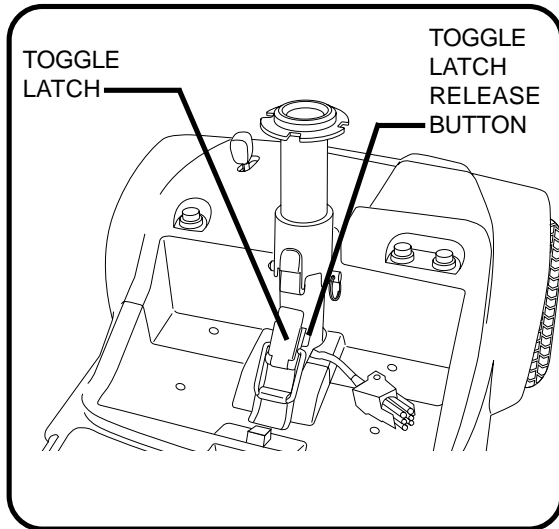

Figure 15. Toggle Latch (Latched)

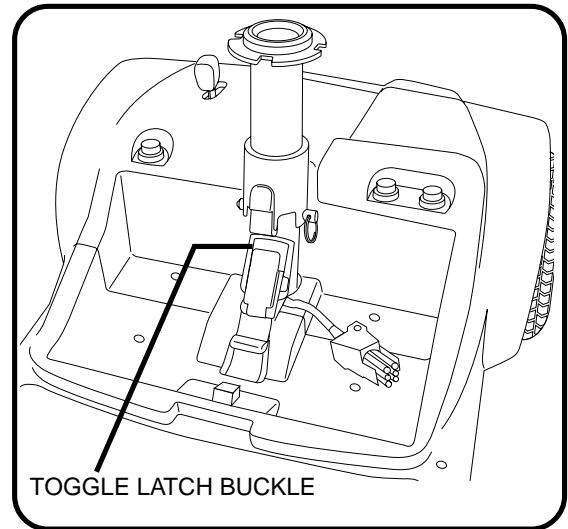

Figure 15A. Toggle Latch (Unlatched)

VIII. DISASSEMBLY AND ASSEMBLY

Frame Separation

1. Push back on the seat post to pivot the scooter's rear section rearward until the rear section is standing vertically on its bumper. See figure 16.
2. Lift the front section up until the lower pegs are no longer in the curved locking brackets. See figure 17.
3. Carefully lift the front section away from the rear section. See figure 18.

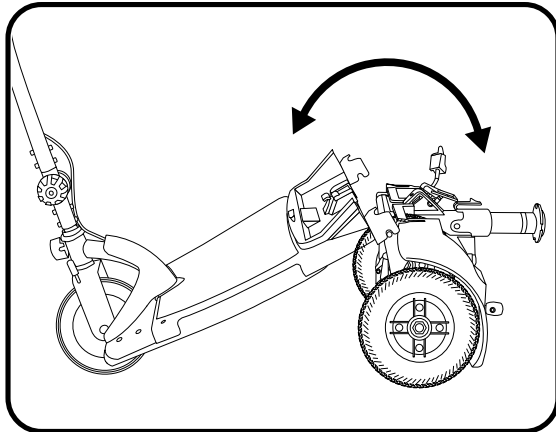

Figure 16. Frame Positioning

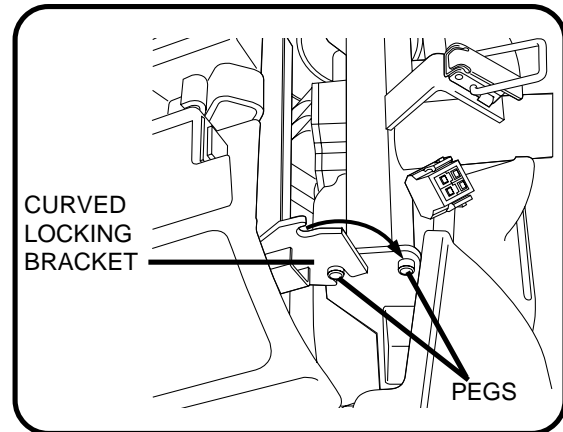

Figure 17. Frame Lockup

ASSEMBLY

1. Position the front and rear sections of your scooter as shown in figure 18.
2. Holding the seat post, slowly pivot the rear section forward until the curved locking brackets are fully connected onto the top rear pegs. See figure 16 and 17.
3. Loosen the tiller adjustment knob, raise the tiller, then retighten the tiller adjustment knob.
4. Secure the toggle latch. See figure 15.
 - Lower the toggle latch buckle.
 - Push the toggle latch so it locks into place.
5. Connect the front-to-rear harness.
6. Reinstall the battery pack by lowering it straight down until it is securely in place.
7. Replace the seat and rotate it until it locks into its correct position.
8. Unlock the front wheel by turning the tiller lock knob 90° anticlockwise. See figure 12.

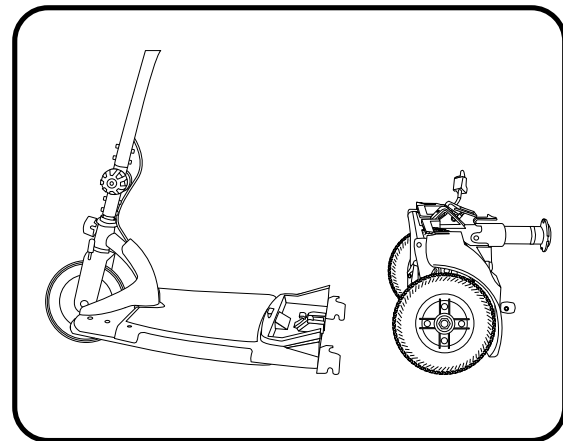

Figure 18. Frame Sections



WARNING! After assembling the scooter, make absolutely certain the tiller lock knob is in the unlocked position before attempting to ride your scooter.

IX. BASIC TROUBLESHOOTING

Any electromechanical device requires occasional troubleshooting. However, most problems that arise can usually be solved with a bit of thought and common sense. Many of these problems occur because the batteries are not fully charged or because the batteries are worn down and can no longer hold a charge.

DIAGNOSTIC BEEP CODES

The diagnostic beep codes for your scooter are designed to help you perform basic troubleshooting quickly and easily. A diagnostic beep code will beep in the event one of the conditions listed below develops.



NOTE: Your scooter will not run unless the beep code condition is resolved and the scooter has been turned off, then turned back on.

BEEP CODE	CONDITION	SOLUTION
■ ■ (2)	Battery voltage is too low to operate the scooter.	Charge fully until charger and any meters indicate completion.
■ ■ ■ (3)	The scooter's battery voltage is too high to operate the scooter.	Call your authorised Pride Provider for assistance.
■ ■ ■ ■ ■ (5)	Solenoid brake trip. The manual freewheel lever may be in the freewheel position.	Remove the key, then push the manual freewheel lever to the drive position, restart your scooter.
■ ■ ■ ■ ■ ■ ■ (6)	Throttle trip. The throttle control lever may have been depressed while inserting the key.	Release the throttle control lever completely, then reinsert the key.
■ ■ ■ ■ ■ ■ ■ ■ (7)	Throttle trip. Throttle potentiometer fault or speed potentiometer fault.	Call your authorised Pride Provider for assistance.
■ ■ ■ ■ ■ ■ ■ ■ ■ (8)	The scooter's motor is disconnected.	Call your authorised Pride Provider for assistance.
■ ■ ■ ■ ■ ■ ■ ■ ■ ■ (9)	Possible controller trip. You may be attempting to install the battery pack while the key is inserted or the motor controller may be in overheat protective mode.	Shut down your scooter for a minimum of several minutes to allow the controller to cool. Or, try reinserting the key into the key switch.

What if the motor runs but my scooter does not move?

- Your scooter was probably left in freewheel mode.
- When the manual freewheel lever is pushed forward, the brakes are disengaged and all power to the motor/transaxle is cut.
- Pull the manual freewheel lever rearward to restore normal operation to your scooter.

What if the main circuit breaker trips repeatedly?

- Charge the scooter's batteries more frequently. See V. "Batteries and Charging."
- See V. "Batteries and Charging" or III. "Specifications" for information about your scooter's battery type.
- If the main circuit breaker trips repeatedly, see your authorised Pride Provider for service.

What if the battery condition metre dips way down and the motor surges or hesitates when I press the throttle control lever?

- Fully charge your scooter's batteries. See V. "Batteries and Charging."
- Have your authorised Pride Provider load test each battery.

IX. BASIC TROUBLESHOOTING

What if all the systems on my scooter seem to be “dead”?

- Make certain that the key is fully inserted into the key switch.
- Check that the batteries are fully charged. See V. “Batteries and Charging.”
- Make certain the battery pack is seated properly.
- Push in the main circuit breaker’s reset button. See IV. “Your Scooter.”
- Make certain the front-to-rear harness is firmly connected.
- Be sure the power down timer feature hasn’t been activated. See below.

POWER DOWN TIMER FEATURE

Your scooter is equipped with an energy saving automatic power down timer feature designed to preserve your scooter’s battery life. If you mistakenly leave the key in the key switch but do not use your scooter for approximately 20 minutes, the scooter’s controller shuts down automatically.

If the power down timer feature takes effect, perform the following steps to resume normal operation.

1. Remove the key from the key switch.
2. Insert the key back into the key switch.

If you experience any problems with your scooter that you are not able to solve, contact your authorised Pride Provider for information on maintenance and service.

X. CARE AND MAINTENANCE

Your scooter requires a minimal amount of care and maintenance. If you do not feel confident in your ability to perform the maintenance listed below, you may schedule inspection and maintenance with your authorised Pride Provider. The following areas require periodic inspection and/or care and maintenance.

TYRE CONDITION AND TREAD WEAR

- Regularly inspect your scooter's tyres for signs of wear.
- Use a rubber conditioner on your scooter's tyre sidewalls to help to preserve them.



WARNING! Do not apply rubber conditioner on tyre tread; this may cause the tyres to become dangerously slippery.

EXTERIOR SURFACES

- Bumpers and trim benefit from an occasional application of rubber or vinyl conditioner.



WARNING! Do not apply a rubber or vinyl conditioner on a scooter's vinyl seat or floorboard mats; they will become dangerously slippery.

- The scooter shroud is made from durable ABS plastic and is coated with an advanced formula urethane paint.
- A light application of car wax will help the shroud retain its high gloss.

WIRING HARNESS

- Regularly check the front-to-rear harness insulation for wear or damage.
- Have your authorised Pride Provider repair or replace any damaged connector, connection, or insulation that you find before using your scooter again.

AXLE BEARINGS AND THE MOTOR/TRANSAXLE ASSEMBLY

These items are all prelubricated, sealed, and require no subsequent lubrication.

CONSOLE, CHARGER, AND ELECTRONICS

- Keep these areas free of moisture.
- If any of these items do become exposed to moisture, let them dry thoroughly before operating your scooter again.

STORAGE

If you plan on not using your scooter for an extended period of time, it is best to:

- Fully charge its batteries prior to storage.
- Remove the battery pack.
- Store your scooter in a warm, dry environment.
- Avoid storing your scooter where it will be exposed to temperature extremes.



WARNING! Always protect batteries from freezing temperatures and never charge a frozen battery. This damages the battery and can cause personal injury.

For prolonged storage, you may wish to place several boards under the frame of your scooter to raise the scooter off of the ground. This takes the weight off the tyres and reduces the possibility of flat spots developing on the areas of the tyres contacting the ground.

XI. WARRANTY

ONE-YEAR LIMITED WARRANTY

Your Pride Scooter is fully guaranteed for twelve (12) months from the date of purchase against faults arising due to defects in manufacture or materials. This warranty does not detract from, but is in addition to your legal rights.

All electronic parts, including controllers and battery chargers, have a one (1) year warranty. Servicing to the controller or battery charger must be carried out by your authorised Pride Provider. Any attempt to open or dismantle these items renders the guarantee void on that item.

NOT COVERED UNDER WARRANTY

This guarantee does not extend to those items which may need replacement due to normal wear and tear (tyres, belts, bulbs, upholstery, plastic shrouds, motor brushes, fuses, and batteries), or damage to the product caused by misuse or accident for which Pride or its agent cannot be held responsible. This warranty does not include labor or service calls.

BATTERIES

Batteries are covered by a six (6) month warranty from the original manufacturer.

Gradual deterioration in performance due to being left in a discharged state, left in cold conditions for long periods of time, or worn out through heavy use is not covered.

SERVICE CHECKS AND WARRANTY SERVICE

Warranty service can be performed by an authorised Pride Provider. Please contact your authorised Pride Provider for advice on the current cost affecting the service visit.

REPLACEMENT UNITS

The availability of replacement units is subject to the discretion of the Provider, not the manufacturer. For more information regarding replacement units, contact your authorised Pride Provider.



Pride
Mobility Products Australia Pty. Ltd.

**21 Healey Road
Dandenong, 3175
Victoria, Australia**

www.pridemobility.com