

MAXIMA



OWNER'S MANUAL

Pride[®]
Mobility Products Ltd.
www.pridemobility.com

32 Wedgwood Road Bicester, Oxon OX26 4UL

SAFETY GUIDELINES



WARNING! An authorised Pride Dealer or qualified technician must perform the initial setup of this scooter and must perform all of the procedures in this manual.

The symbols below are used throughout this owner's manual and on the scooter to identify warnings and important information. It is very important for you to read them and understand them completely.



WARNING! Indicates a potentially hazardous condition/situation. Failure to follow designated procedures can cause either personal injury, component damage or malfunction. On the product, this icon is represented as a black symbol on a yellow triangle with a black border.



MANDATORY! These actions should be performed as specified. Failure to perform mandatory actions can cause personal injury and/or equipment damage. On the product, this icon is represented as a white symbol on a blue dot with a white border.



PROHIBITED! These actions are prohibited. These actions should not be performed at any time or in any circumstances. Performing a prohibited action can cause personal injury and/or equipment damage. On the product, this icon is represented as a black symbol with a red circle and red slash.

Please fill out the following information for quick reference:

Pride Dealer: _____
Address: _____
Phone Number: _____
Purchase Date: _____ Serial Number: _____

NOTE: *This owner's manual is compiled from the latest specifications and product information available at the time of publication. We reserve the right to make changes as they become necessary. Any changes to our products may cause slight variations between the illustrations and explanations in this manual and the product you have purchased. The latest/current version of this manual is available on our website.*

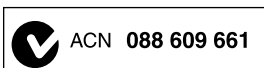

CONTENTS

I. INTRODUCTION	4
II. SAFETY	5
III. YOUR SCOOTER	15
IV. BATTERIES AND CHARGING	19
V. OPERATION	24
VI. COMFORT ADJUSTMENTS	26
VII. DISASSEMBLY AND ASSEMBLY	30
VIII. BASIC TROUBLESHOOTING	33
IX. CARE AND MAINTENANCE	35
X. WARRANTY	39
APPENDIX I - SPECIFICATIONS	40

I. INTRODUCTION

SAFETY

WELCOME to Pride Mobility Products (Pride). The scooter you have purchased combines state-of-the-art components with **safety**, comfort and styling in mind. We are confident that these design features will provide you with the conveniences you expect during your daily activities. Once you understand how to **safely** operate and care for your scooter, it should give you years of trouble-free operation and service.

Read and follow all instructions, warnings and notes in this manual and all other accompanying literature before attempting to operate this product for the first time. In addition, your **safety** depends upon you, as well as your dealer, carer or healthcare professional in using good judgement.

If there is any information in this manual which you do not understand or if you require additional assistance for setup or operation, please contact your authorised Pride Dealer. **Failure to follow the instructions in this manual and those located on your scooter can lead to personal injury and/or damage to the scooter, including voiding the warranty.**

PURCHASER'S AGREEMENT

By accepting delivery of this product, you promise that you will not change, alter or modify this product or remove or render inoperable or unsafe any guards, shields or other safety features of this product; fail, refuse or neglect to install any retrofit kits from time to time provided by Pride to enhance or preserve the safe use of this product.

SHIPPING AND DELIVERY

Before using your scooter, make sure your delivery is complete as some components may be individually packaged. If you do not receive a complete delivery, please contact your authorised Pride Dealer immediately. Where damage has occurred during transport, either to the packaging or content, please contact the delivery company responsible.

INFORMATION EXCHANGE

We want to hear your questions, comments and suggestions about this manual. We would also like to hear about the safety and reliability of your new scooter and about the service you received from your authorised Pride Dealer. Please notify us of any change of address, so we can keep you apprised of important information about safety, new products and new options that can increase your ability to use and enjoy your scooter. Please feel free to contact us at the address below:

Pride Mobility Products Ltd.
32 Wedgwood Road
Bicester, Oxon OX26 4UL

NOTE: If you ever lose or misplace your product registration card or your copy of this manual, contact us and we will be glad to send you a new one immediately.

II. SAFETY

PRODUCT SAFETY SYMBOLS

The symbols below are used on the scooter to identify warnings, mandatory actions and prohibited actions. It is very important for you to read and understand them completely.



Read and follow the information in the owner's manual.



Removal of grounding prong can create electrical hazard. If necessary, properly install an approved 3-pronged adapter to an electrical outlet having 2-pronged plug access.

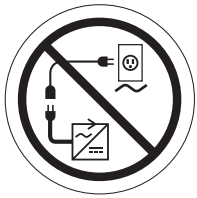

Do not connect an extension lead to the AC/DC converter or the battery charger.

II. SAFETY

GENERAL



MANDATORY! Do not operate your new scooter for the first time without completely reading and understanding this owner's manual.

Your scooter is a state-of-the-art life-enhancement device designed to increase mobility. Pride provides an extensive variety of products to best fit the individual needs of the scooter user. Please be aware that the final selection and purchasing decision regarding the type of scooter to be used is the responsibility of the scooter user, who is capable of making such a decision, and his/her healthcare professional (i.e., medical doctor, physical therapist, etc.).

The contents of this manual are based on the expectation that a mobility device expert has properly fitted the scooter to the user and has assisted the prescribing healthcare professional and/or the authorised Pride Dealer in the instruction process for the use of the product.

There are certain situations, including some medical conditions, where the scooter user will need to practice operating the scooter in the presence of a trained attendant. A trained attendant can be defined as a family member or care professional specially trained in assisting a scooter user in various daily living activities.

As you begin using your scooter during daily activities, you will probably encounter situations in which you will need some practice. Simply take your time and you will soon be in full and confident control as you manoeuvre through doorways, on and off lifts, up and down ramps and over moderate terrain.

Below are some precautions, tips and other safety considerations that will help you become accustomed to operating the scooter safely.

MODIFICATIONS

Pride has designed and engineered your scooter to provide maximum mobility and utility. A wide range of accessories is available from Pride to further customise your scooter to better suit your needs and/or preferences. However, under no circumstances should you modify, add, remove or disable any feature, part or function of your scooter.



WARNING! Do not modify your scooter in any way not authorised by Pride. Do not use accessories if they have not been tested or approved for Pride products.

REMOVABLE PARTS



WARNING! Do not attempt to lift or move your scooter by any of its removable parts, including the armrests, seat or shroud.

PRE-RIDE SAFETY CHECK

Get to know the feel of your scooter and its capabilities. Pride recommends that you perform a safety check before each use to make sure your scooter operates smoothly and safely.

II. SAFETY

Perform the following inspections prior to using your scooter:

- Check for proper tyre inflation. Maintain but do not exceed the psi/bar/kPa air pressure rating indicated on each tyre if equipped with pneumatic tyres.
- Check all electrical connections. Make sure they are tight and not corroded.
- Check all harness connections to the electronics module. Make sure they are secured properly.
- Check the brakes. See IX. "Care and Maintenance."
- Check battery charge. See IV. "Batteries and Charging."

NOTE: *If you discover a problem, contact your authorised Pride Dealer for assistance.*

WEIGHT LIMITATIONS

Your scooter is rated for a maximum weight capacity. Please refer to the specifications table for this limit. Keep in mind that the maximum weight capacity includes the combined weight of the user and any accessories mounted to the scooter.



MANDATORY! Stay within the specified weight capacity of your scooter. Exceeding the weight capacity voids your warranty. Pride will not be held responsible for injuries and/or property damage resulting from failure to observe weight limitations.



WARNING! Do not carry passengers on your scooter. Carrying passengers on your scooter may affect the centre of gravity, resulting in a tip or a fall.

TYRE INFLATION

If your scooter is equipped with pneumatic tyres, you should check or have the air pressure checked at least once a week. Proper inflation pressures will prolong the life of your tyres and help ensure the smooth operation of your scooter.



WARNING! It is critically important that the psi/bar/kPa air pressure rating indicated on the tyre be maintained in pneumatic tyres at all times. Do not underinflate or overinflate your tyres. Low pressure may result in loss of control, and overinflated tyres may burst. Failure to maintain the psi/bar/kPa air pressure rating indicated on pneumatic tyres at all times may result in tyre and/or wheel failure.

WARNING! Inflate your scooter tyres from a regulated air source with an available pressure gauge. Inflating your tyres from an unregulated air source could overinflate them, resulting in a burst tyre.

NOTE: *If the tyres on your scooter list the psi rating only, use the following conversion formulas to find the bar or kPa rating: $bar = psi \times 0.06895$; $kPa = psi \times 6.89476$.*

INCLINE INFORMATION

More and more buildings have ramps with specified degrees of inclination, designed for easy and safe access. Some ramps may have turning switchbacks (180-degree turns) that require you to have good cornering skills on your scooter.

- Proceed with extreme caution as you approach the downgrade of a ramp or other incline.
- Take wide swings with your scooter's front wheel(s) around any tight corners. If you do that, the scooter's rear wheels will follow a wide arc, not cut the corner short and not bump into or get hung up on any railing corners.
- When driving down a ramp, keep the scooter's speed adjustment set to the slowest speed setting to ensure a safely controlled descent.
- Avoid sudden stops and starts.

II. SAFETY

When climbing an incline, try to keep your scooter moving. If you must stop, start up again slowly and then accelerate cautiously. When driving down an incline, do so by setting the speed adjustment dial to the slowest setting and driving in the forward direction only. If your scooter starts to move down the incline faster than you anticipated or desired, allow it to come to a complete stop by releasing the throttle control lever. Then push the throttle control lever forward slightly to ensure a safely controlled descent.

WARNING! When on any sort of an incline or decline, never place the scooter in freewheel mode, especially while seated on it or standing next to it.

WARNING! When climbing an incline, do not zigzag or drive at an angle up the face of the incline. Drive your scooter straight up the incline. This greatly reduces the possibility of a tip or a fall. Always exercise extreme caution when negotiating an incline.



WARNING! Do not drive your scooter across the side of an incline or diagonally up or down an incline; do not stop, if possible, while driving up or down an incline.

WARNING! You should not travel up or down a potentially hazardous incline (i.e., areas covered with snow, ice, cut grass or wet leaves).

WARNING! Even though your scooter is capable of climbing slopes greater than those illustrated in figure 1, do not, under any circumstances, exceed the incline guidelines or any other specifications presented in this manual. Doing so could cause instability in your scooter.

Handicap public access ramps are not subject to government regulation in all countries, and therefore do not necessarily share the same standard percent of slope. Other inclines may be natural or, if man-made, not designed specifically for scooters. **Figure 1** illustrates your scooter's stability and its ability to climb grades under various weight loads and under controlled testing conditions.

These tests were conducted with the scooter's seat in the highest position and adjusted rearward on the seat base to its farthest rearward position. Use this information as a guideline. Your scooter's ability to travel up inclines is affected by your weight, your scooter's speed, your angle of approach to the incline and your scooter setup.



WARNING! Any attempt to climb or descend a slope steeper than what is shown in figure 1 may put your scooter in an unstable position and cause it to tip.

WARNING! Never carry an oxygen tank weighing more than 6.8 kg (15 lbs.). Never fill the rear basket with contents exceeding 6.8 kg (15 lbs.).

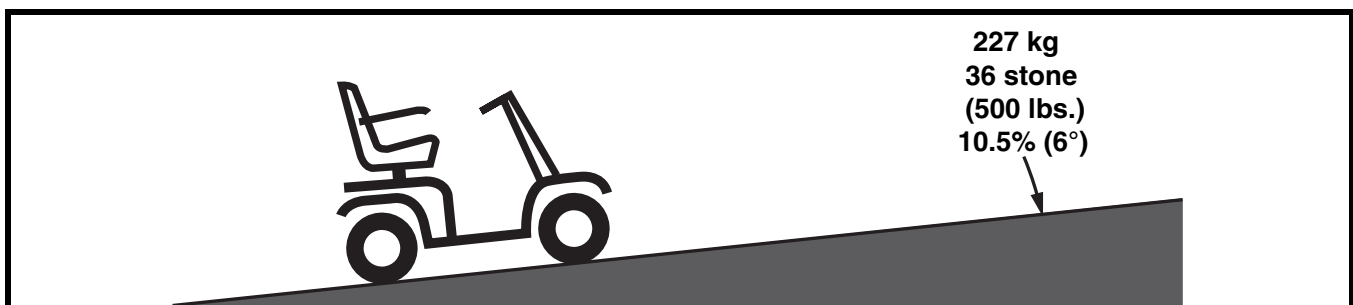

Figure 1. Maximum Recommended Incline Angle

II. SAFETY

When you approach an incline, it is best to lean forward. See figures 2 and 2A. This shifts the centre of gravity of you and your scooter toward the front of the scooter for improved stability.

NOTE: When negotiating ramps, if the throttle control lever is released while moving forward, the powered scooter may "rollback" approximately 30.5 cm (1 foot) before the brake engages. If the throttle control lever is released while moving in reverse, the powered scooter may "rollback" approximately 3 feet (1 metre) before the brake engages.

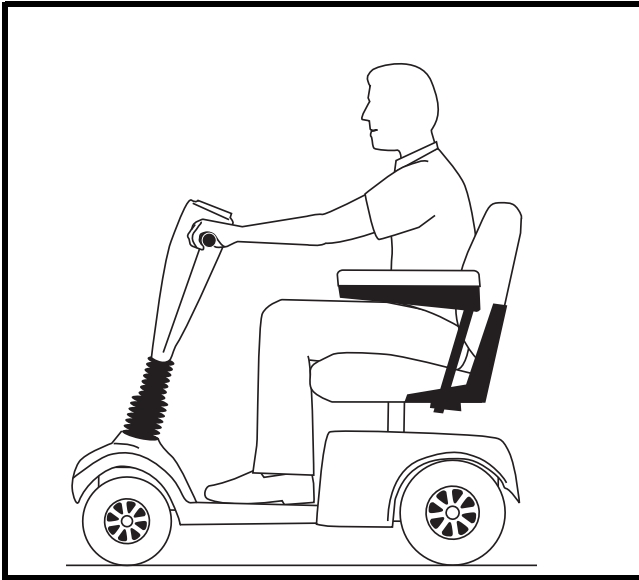

Figure 2. Normal Driving Position

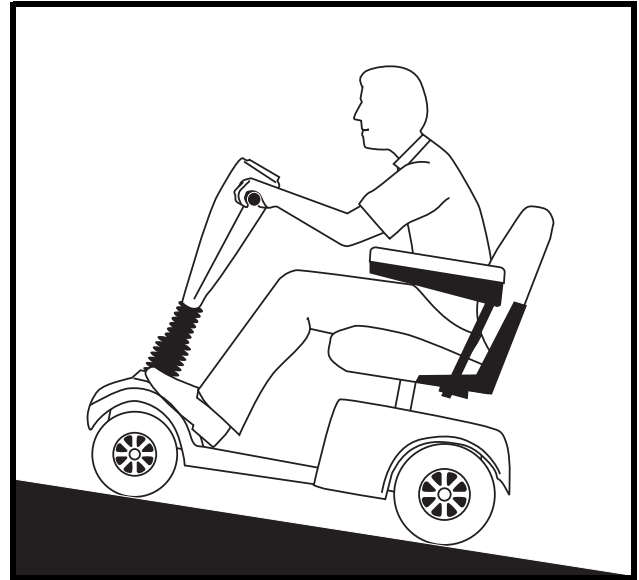

Figure 2A. Increased Stability Driving Position

CORNERING INFORMATION

Excessively high cornering speeds can create the possibility of tipping. Factors which affect the possibility of tipping include, but are not limited to, cornering speed, steering angle (how sharply you are turning), uneven road surfaces, inclined road surfaces, riding from an area of low traction to an area of high traction (such as passing from a grassy area to a paved area – especially at high speed while turning) and abrupt directional changes. High cornering speeds are not recommended. If you feel that you may tip over in a corner, reduce your speed and steering angle (i.e., lessen the sharpness of the turn) to prevent your scooter from tipping.



WARNING! When cornering sharply, reduce your speed and maintain a stable centre of gravity. When using your scooter at higher speeds, do not corner sharply. This greatly reduces the possibility of a tip or fall.

BRAKING INFORMATION

Your scooter is equipped with two powerful brake systems:

- Regenerative: Uses electricity to rapidly slow the vehicle when the throttle control lever returns to the centre/stop position.
- Disc Park Brake: Activates mechanically after regenerative braking slows the vehicle to near stop or when power is removed from the system for any reason.

II. SAFETY

OUTDOOR DRIVING SURFACES

Your scooter is designed to provide optimum stability under normal driving conditions—dry, level surfaces composed of concrete, blacktop or tarmac. However, Pride recognises that there will be times when you will encounter other surface types. For this reason, your scooter is designed to perform admirably on packed soil, grass and gravel. Feel free to use your scooter safely on lawns and in park areas.

- Avoid driving on uneven terrain and/or soft surfaces.
- Avoid tall grass that can become tangled in the running gear.
- Avoid loosely packed gravel and sand.
- Do not use your scooter in fresh or salt water.
- Do not use your scooter at the edge of a stream, lake or ocean.
- If you feel unsure about a driving surface, avoid that surface.

PUBLIC STREETS AND ROADWAYS



WARNING! Exercise extreme caution when operating the scooter on footpaths, pavements, bridleways, pedestrian areas and roads. Obey all local pedestrian traffic rules.

STATIONARY OBSTACLES (STEPS, KERBS, ETC.)

WARNING! Do not drive near raised surfaces, unprotected ledges and/or drop-offs (kerbs, porches, stairs, etc.).

WARNING! Do not attempt to have your scooter climb or descend an obstacle that is inordinately high.



WARNING! Do not attempt to have your scooter proceed rearward down any step, kerb or other obstacle. This may cause the scooter to tip.

WARNING! Be sure your scooter is traveling perpendicular to any kerb you may be required to ascend or descend. See figures 3 and 4.

WARNING! Even though your scooter may be capable of handling greater obstacles, Pride recommends that you do not attempt to negotiate a kerb that has a height greater than 5 cm (2 in.). Doing so could cause instability in your scooter.

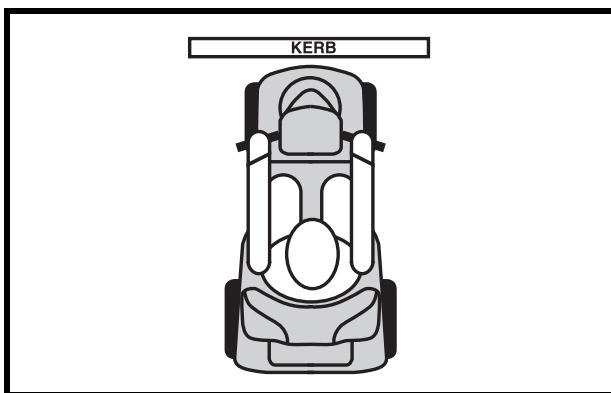

Figure 3. Correct Kerb Approach

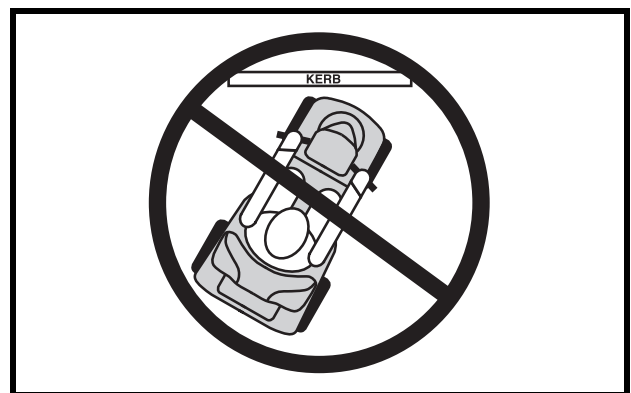

Figure 4. Incorrect Kerb Approach

II. SAFETY

INCLEMENT WEATHER PRECAUTIONS

Exposure of your scooter to inclement weather conditions should be avoided whenever possible. If suddenly caught up in rain, snow, severe cold or heat while operating your scooter proceed to shelter at the earliest opportunity. Thoroughly dry your scooter before storing, charging or operating your scooter.



PROHIBITED! Operating in rain, snow, salt, mist/spray conditions and on icy/slippery surfaces can cause damage to the scooter and electrical system. Maintain and store your scooter in a dry and clean condition.



WARNING! Prolonged exposure to hot or cold conditions may affect the temperature of upholstered and non-upholstered items on the scooter, possibly resulting in skin irritation. Exercise caution when using your scooter in extremely hot or cold conditions or when exposing your scooter to direct sunlight for prolonged periods of time.

FREEWHEEL MODE

Your scooter is equipped with a manual freewheel lever that, when engaged, allows the scooter to be pushed. For more information about how to place your scooter into and out of freewheel mode, see III. “Your Scooter.”



WARNING! When your scooter is in freewheel mode, the braking system is disengaged.

- **Disengage the drive motors only on a level surface.**
- **Ensure the key is removed from the key switch.**
- **Stand behind the scooter to engage or disengage freewheel mode. Never sit on a scooter to do this.**
- **After you have finished pushing your scooter, always return it to the drive mode to lock the brakes.**

An added feature built into the scooter is “push-too-fast” protection which safeguards the scooter against gaining excessive speed while in freewheel mode.

“Push-too-fast” operates differently depending on which of two conditions exists:

- If the key is switched “off” when in freewheel mode, the scooter’s controller activates regenerative braking when the scooter is pushed faster than a maximum threshold which has been preprogrammed. In this case, the controller is acting as a speed governor.
- If the key is switched “on” while in freewheel mode, you will encounter considerable resistance at any speed. This prevents the scooter from gaining unwanted momentum should the manual freewheel lever inadvertently be released while driving the scooter.

STAIRS AND ESCALATORS

Scooters are not designed to travel up or down stairs or escalators. Always use a lift.



WARNING! Do not use your scooter to negotiate steps or escalators.

DOORS

- Determine if the door opens toward or away from you.
- Use your hand to turn the knob or push the handle or push-bar.
- Drive your scooter gently and slowly forward to push the door open. Or drive your scooter gently and slowly rearwards to pull the door open.

II. SAFETY

LIFTS

Modern lifts have a door edge safety mechanism that, when pushed, reopens the lift door(s).

- If you are in the doorway of a lift when the door(s) begin to close, push on the rubber door edge or allow the rubber door edge to contact the scooter and the door will reopen.
- Use care that handbags, packages or scooter accessories do not become caught in lift doors.

NOTE: If your scooter's turning radius is greater than 152.4 cm (60 in.), it may be difficult to manoeuvre in lifts and building entrances. Use caution when attempting to turn or manoeuvre your scooter in small spaces, and avoid areas that might pose a problem.

LIFT/ELEVATION PRODUCTS

If you will be transporting your scooter during travel, you may find it necessary to use a vehicle-mounted lift system or elevation product to aid in transportation. Pride recommends that you closely review the warnings, instructions, specifications and safety information set forth by the manufacturer of the lift/elevation product before using that product.

WARNING! Not all lift systems/elevation products are rated for use with an occupied mobility device. Pride recommends that you do not remain seated in your scooter when it is being used in connection with any type of lift system/elevation product unless:

- That product is rated for occupied use by the manufacturer.
- You are able to occupy your mobility device in strict conformity with the warnings, instructions, specifications and safety guidelines set forth by the manufacturer.



WARNING! Always turn off the power to the unit when you are being transferred via an elevation product. Failure to do so may result in accidental throttle control lever contact, resulting in unintended movement and personal injury or product damage.

BATTERIES

In addition to following the warnings below, be sure to comply with all other battery handling information.



MANDATORY! Battery posts, terminals and related accessories contain lead and lead compounds. Wear goggles and gloves when handling batteries and wash hands after handling.

WARNING! Scooter batteries are heavy. See specifications table. If you are unable to lift that much weight, be sure to get help. Use proper lifting techniques and avoid lifting beyond your capacity.



WARNING! Always protect the batteries from freezing and never charge a frozen battery. Charging a frozen battery may result in damage to the battery.

WARNING! Connect the battery harnesses in the proper manner. RED (+) cables must be connected to positive (+) battery terminals/posts. BLACK (-) cables must be connected to negative (-) battery terminals/posts. Protective caps should be installed over all battery terminals. REPLACE cables immediately if damaged.

BATTERY DISPOSAL AND RECYCLING

If you encounter a damaged or cracked battery, immediately enclose it in a plastic bag and contact your local waste disposal agency or your authorised Pride Dealer for instructions on disposal and battery recycling, which is our recommended course of action.

PREVENTING UNINTENDED MOVEMENT



WARNING! If you anticipate being seated in a stationary position for an extended period of time, turn off the power. This will prevent unexpected motion from inadvertent throttle control lever contact.

II. SAFETY

MOTOR VEHICLE TRANSPORT

Pride recommends that you do not remain seated in your scooter while traveling in a motor vehicle. The scooter should be stowed in the boot of a car or in the back of a truck or van with batteries removed and properly secured. In addition, all removable scooter parts, including the armrests, seat and shroud should be removed and/or properly secured during motor vehicle transport.

WARNING! Although your scooter may be equipped with a positioning belt, this belt is not designed to provide proper restraint during motor vehicle transport. Anyone traveling in a motor vehicle should be properly secured in the motor vehicle seat with safety belts fastened securely.



WARNING! Do not sit on your scooter while it is in a moving vehicle.

WARNING! Always be sure your scooter and its batteries are properly secured when it is being transported. Batteries should be secured in an upright position and protective caps should be installed on the battery terminals. Batteries should not be transported with any flammable or combustible items.

POSITIONING BELTS

Your authorised Pride Dealer, therapist(s) and other healthcare professionals are responsible for determining your requirement for a positioning belt in order to operate your scooter safely.



WARNING! If you require a positioning belt to safely operate your scooter, make sure it is fastened securely in order to reduce the possibility of a fall from the scooter.

GETTING ONTO AND OFF OF YOUR SCOOTER

Getting onto and off of your scooter requires a good sense of balance. Please observe the following safety tips when getting onto and off of your scooter:

- Remove the key from the key switch.
- Ensure that your scooter is not in freewheel mode. See III. “Your Scooter.”
- Make certain that the seat is fixed into place.
- Flip up the armrests to make getting on and off the scooter easier.

WARNING! Position yourself as far back as possible in the scooter seat to prevent the scooter from tipping.



WARNING! Avoid putting all your weight on the scooter armrests and do not use the armrests for weight bearing purposes, such as transfers. Such use may cause the scooter to tip, resulting in a fall from the scooter and/or personal injury.

WARNING! Avoid putting all of your weight on the floorboard. Such use may cause the scooter to tip.

REACHING AND BENDING

Avoid reaching or bending while driving your scooter. Bending forward creates the risk of accidental throttle control lever contact. Bending to the side while seated creates the risk of tipping. It is important to maintain a stable centre of gravity and keep the scooter from tipping. Pride recommends that the scooter user determine his/her personal limitations and practice bending and reaching in the presence of a qualified attendant.



WARNING! Do not bend, lean or reach for objects if you have to pick them up from the scooter deck or from either side of the scooter. Movements such as these may change your centre of gravity and the weight distribution of the scooter and cause your scooter to tip.



PROHIBITED! Keep your hands away from the tyres when driving. Be aware that loose fitting clothing can become caught in drive tyres.

II. SAFETY

PRESCRIPTION DRUGS/PHYSICAL LIMITATIONS

The scooter user must exercise care and common sense when operating his/her scooter. This includes awareness of safety issues when taking prescribed or over-the-counter drugs or when the user has specific physical limitations.



WARNING! Consult your physician if you are taking prescribed or over-the-counter medication or if you have certain physical limitations. Some medications and limitations may impair your ability to operate your scooter in a safe manner.

ALCOHOL/SMOKING

The scooter user must exercise care and common sense when operating his/her scooter. This includes awareness of safety issues while under the influence of alcohol or while smoking.

WARNING! Do not operate your scooter while you are under the influence of alcohol, as this may impair your ability to operate the scooter in a safe manner.



WARNING! Pride strongly recommends that you do not smoke cigarettes while seated on your scooter, although the scooter seat has passed the necessary testing requirements for cigarette smoking. You must adhere to the following safety guidelines if you decide to smoke cigarettes while seated on your scooter.

- Do not leave lit cigarettes unattended.
- Keep ashtrays a safe distance from the seat cushions.
- Always make sure cigarettes are completely extinguished before disposal.

ELECTROMAGNETIC AND RADIO FREQUENCY INTERFERENCE (EMI/RFI)



WARNING! Laboratory tests have shown that electromagnetic and radio frequency waves can have an adverse affect on the performance of electrically-powered mobility vehicles.

Electromagnetic and Radio Frequency Interference can come from sources such as cellular phones, mobile two-way radios (such as walkie-talkies), radio stations, TV stations, amateur radio (HAM) transmitters, wireless computer links, microwave signals, paging transmitters and medium-range mobile transceivers used by emergency vehicles. In some cases, these waves can cause unintended movement or damage to the control system. Every electrically-powered mobility vehicle has an immunity (or resistance) to EMI. The higher the immunity level, the greater the protection against EMI. This product has been tested and has passed at an immunity level of 20 V/M.

WARNING! Be aware that cell phones, two-way radios, laptops and other types of radio transmitters may cause unintended movement of your electrically-powered mobility vehicle due to EMI. Exercise caution when using any of these items while operating your mobility vehicle and avoid coming into close proximity of radio and TV stations.



WARNING! The addition of accessories or components to the electrically-powered mobility vehicle can increase the susceptibility of the vehicle to EMI. Do not modify your scooter in any way not authorised by Pride.

WARNING! The electrically-powered mobility vehicle itself can disturb the performance of other electrical devices located nearby, such as alarm systems.

NOTE: For further information on EMI/RFI, visit the Resource Center on www.pridemobility.com. If unintended motion or brake release occurs, turn your scooter off as soon as it is safe to do so. Contact your authorised Pride Dealer to report the incident.

III. YOUR SCOOTER

CONTROL CONSOLE ASSEMBLY

The control console assembly houses all of the controls you need to drive your scooter, including the key switch, speed adjustment dial, status LED, throttle control lever, battery condition meter, horn buttons, lights switch, turn indicator buttons, off-board charger port and the hazard lights switch. See figure 5.



PROHIBITED! Do not expose the control console assembly to moisture. In the event that the control console assembly does become exposed to moisture, do not attempt to operate your scooter until the control console assembly has dried thoroughly.

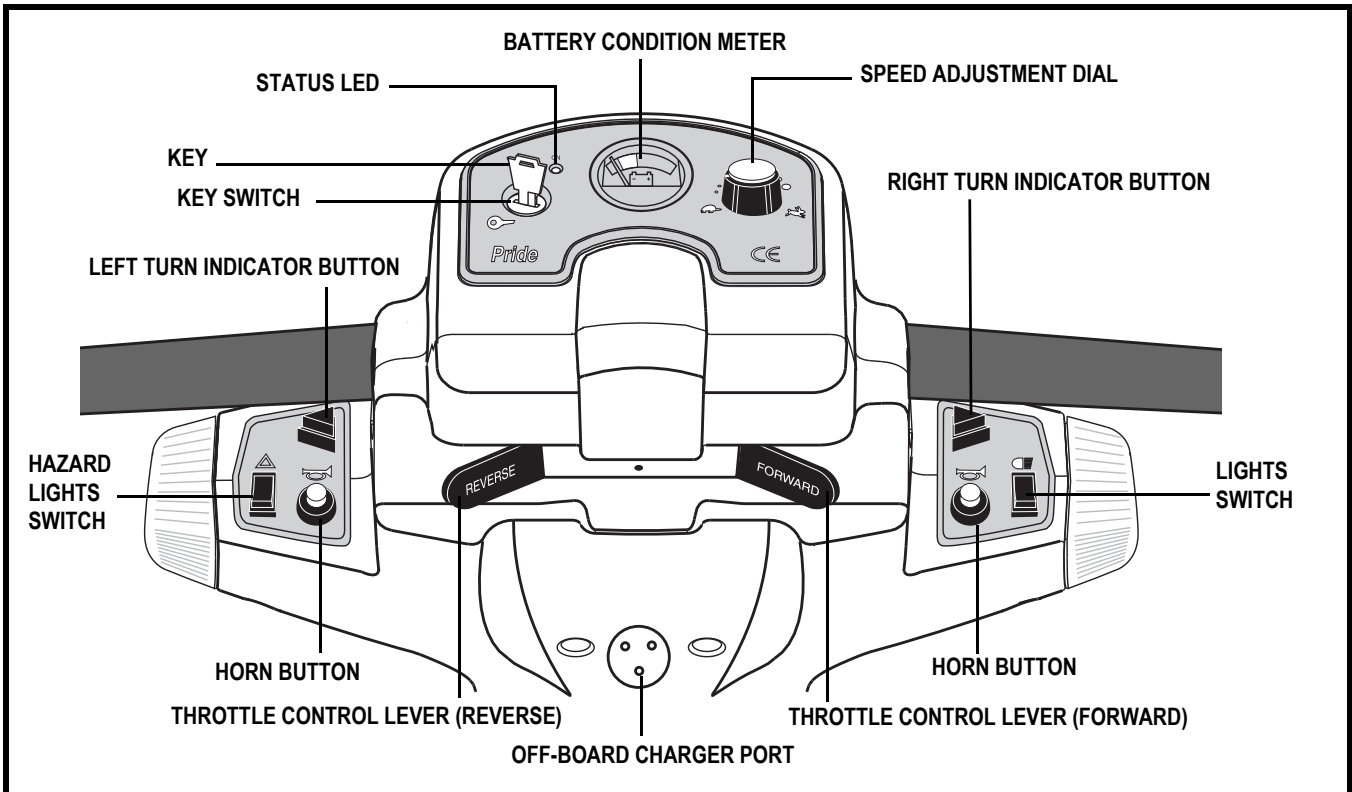

Figure 5. Control Console Assembly

Key Switch

- Fully insert the key into the key switch and turn it clockwise to power up (turn on) your scooter.
- Turn the key anticlockwise to power down (turn off) your scooter.



WARNING! If the key is moved to the “off” position while your scooter is in motion, the electronic brakes engage and your scooter comes to an abrupt stop!

Speed Adjustment Dial

This adjustment dial enables you to preselect and limit your scooter’s top speed.

- The image of the tortoise represents the slowest speed setting.
- The image of the hare represents the fastest speed setting.

Status LED

The Status LED alerts you to electrical problems that may occur with the scooter. The LED remains constantly lit while your scooter is on. If the scooter develops an electrical problem, the status LED will flash a code. See VIII. “Basic Troubleshooting” for troubleshooting flash codes.

III. YOUR SCOOTER

Throttle Control Lever

This lever allows you to control the forward speed and the reverse speed of your scooter up to the maximum speed you preset with the speed adjustment dial.

- Place your right hand on the right handgrip and your left hand on the left handgrip.
- Use your right thumb to push the right side of the lever to disengage your scooter's brakes and move forward.
- Release the lever and allow your scooter to come to a complete stop before pushing the other side of the lever to move in reverse.
- When the throttle control lever is completely released, it automatically returns to the centre "stop" position and engages your scooter's brakes.

Battery Condition Meter

When the key is fully inserted and turned clockwise to power up your scooter, this meter indicates the approximate battery voltage strength. For further information on battery charging, see IV. "Batteries and Charging."

Horn Buttons

These buttons activate a warning horn.

- The key must be inserted and turned clockwise for the horn to be operational.
- Do not hesitate to use the warning horn when its use could prevent accident or injury.

Light Switch

This switch controls your scooter's lighting system. Toggle this switch to turn on and turn off the lights.



WARNING! Scooter users are required to use their lights when visibility is restricted—day or night.

Turn Indicator Buttons

Use these buttons to turn on the left and right turn indicator lights.

- Press the appropriate turn indicator button once to activate it.
- Your scooter's turn indicators are timed to shut off automatically.

Hazard Lights Switch

This switch activates the 4-way flashers on your scooter. Toggle this switch to turn on and turn off the lights.

Off-board Charger Port

The scooter's off-board charger plugs into this port.

III. YOUR SCOOTER

REAR SECTION

The manual freewheel lever, the anti-tip wheels, the motor/transaxle assembly (not shown), the electronics module, the batteries (not shown), the main circuit breaker (reset button) and the fuses are located on the rear section of your scooter. See figure 6. Refer to VII. "Disassembly and Assembly" for instructions on removing the rear shroud.

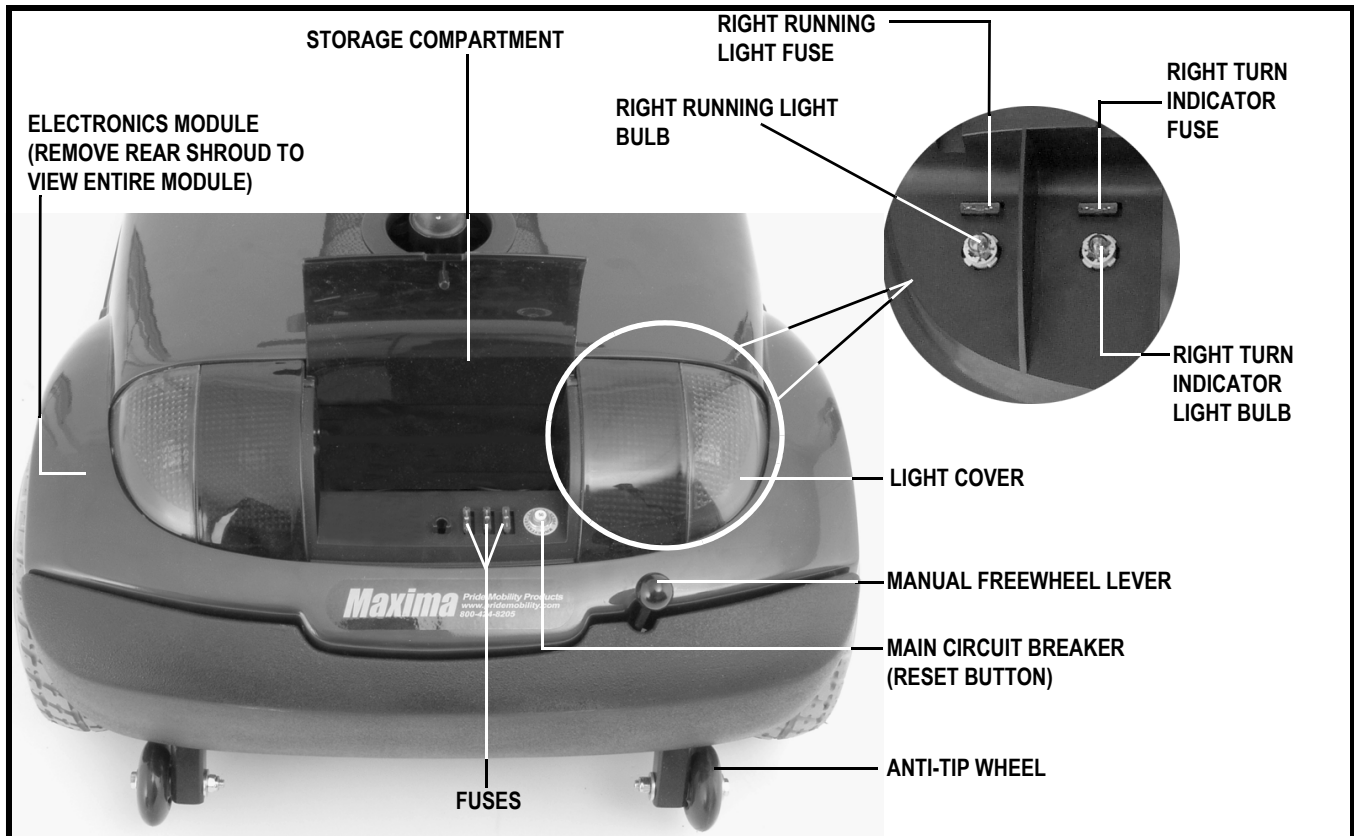

Figure 6. Rear Section

Manual Freewheel Lever

Whenever you need or want to push your scooter for short distances, you can put it in freewheel mode.

1. Pull up firmly on the manual freewheel lever to disable the drive system and the brake system.
2. You may push your scooter.
3. Push down firmly on the manual freewheel lever to reengage the drive system and the brake system and take your scooter out of freewheel mode.

WARNING! When your scooter is in freewheel mode, the braking system is disengaged.

- Disengage the drive motors only on a level surface.
- Ensure the key is removed from the key switch.
- Stand to the side of the scooter to engage or disengage freewheel mode. Never sit on a scooter to do this.
- After you have finished pushing your scooter, always return it to the drive mode to lock the brakes.



III. YOUR SCOOTER

Anti-tip Wheels

The front (not shown) and rear anti-tip wheels are an integral and important safety feature of your scooter. They are bolted to the frame at the front and rear of the scooter.



PROHIBITED! Do not remove the anti-tip wheels or modify your scooter in any way that is not authorised by Pride.

Motor/Transaxle Assembly (Not Shown)

The motor/transaxle assembly is the electromechanical unit that converts the electrical energy of your scooter's batteries into the controlled mechanical energy that drives the scooter's wheels.

Batteries (Not Shown)

The batteries store the electrical energy that powers your scooter. See IV. "Batteries and Charging."

Main Circuit Breaker (Reset Button)

When the voltage in your scooter's batteries becomes low or your scooter is heavily strained because of excessive loads or steep inclines, the main circuit breaker may trip to protect your scooter's motor and electronics from damage. When the breaker trips, the entire electrical system shuts down.

- The main circuit breaker reset button pops out when the breaker trips.
- When the breaker trips, the entire electrical system of your scooter shuts down.
- Allow a minute or two for your scooter's electronics to "rest."
- Push in the reset button to reset the breaker.
- If the breaker trips frequently, you may need to charge your batteries more often. You may also need to have your authorised Pride Dealer perform a load test on your scooter's batteries.
- If the main circuit breaker trips repeatedly, see your authorised Pride Dealer for service.

Fuses

The fuses help protect your scooter's lighting, control console assembly and charging systems from receiving an overload of electrical current. The fuses used in the scooter are the same type automobiles use.

If a fuse must be replaced, use only the specified amp fuse. See IX. "Care and Maintenance."

Docking Device Assembly

Your scooter is equipped with a docking device assembly. See **figure 7**. In order to utilise the docking device, it is necessary to purchase an insert (T-bar or Bullnose and C-arm) that, when used with the lift system, will aid in lifting your scooter.

Contact your authorised Pride Dealer for more information about the docking device.

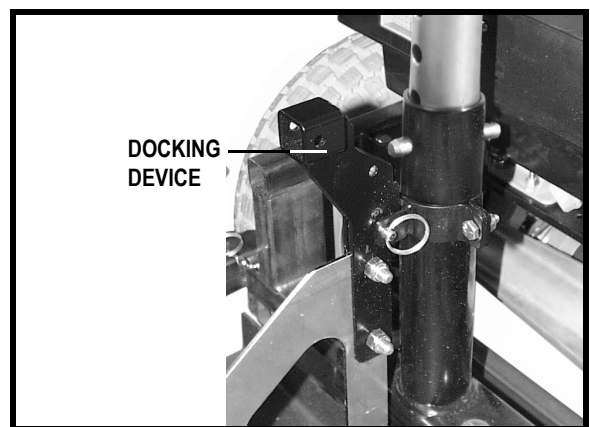

Figure 7. Docking Device Assembly

IV. BATTERIES AND CHARGING

BATTERIES AND CHARGING

Your scooter requires two long-lasting, 12-volt, deep-cycle batteries that are sealed and maintenance free. They are recharged by an off-board charging system.

- Charge your scooter's batteries prior to using it for the first time.
- Keep the batteries fully charged to keep your scooter running smoothly.

READING YOUR BATTERY VOLTAGE

The battery condition meter on the control console assembly indicates the approximate strength of your batteries using a colour code. From right to left, green indicates fully charged batteries, yellow indicates a draining charge and red indicates that an immediate recharge is necessary. See figure 8. To ensure the highest accuracy, the battery condition meter should be checked while operating your scooter at full speed on a dry, level surface.

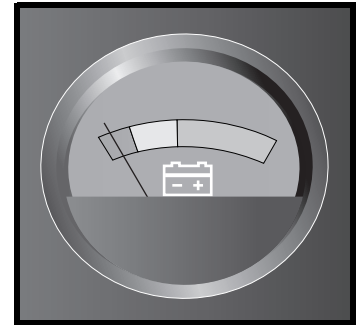

Figure 8. Battery Condition Meter

CHARGING YOUR BATTERIES



PROHIBITED! Never use an extension lead to plug in your battery charger. Plug the charger directly into a properly wired standard electrical outlet.



PROHIBITED! Removal of grounding prong can create electrical hazard. If necessary, properly install an approved 3-pronged adapter to an electrical outlet having 2-pronged plug access.



PROHIBITED! Do not allow unsupervised children to play near the scooter while the batteries are charging. Pride recommends that you do not charge the batteries while the scooter is occupied.



MANDATORY! Read the battery charging instructions in this manual and in the manual supplied with the battery charger before charging the batteries.

WARNING! Explosive gases may be generated while charging the batteries. Keep the scooter and battery charger away from sources of ignition such as flames or sparks and provide adequate ventilation when charging the batteries.

WARNING! Ensure that both ends of the charger power lead are clean and dry before plugging the charger power lead into the off-board charger port or the electrical outlet.

WARNING! Inspect the battery charger, wiring and connectors for damage before each use. Contact your authorised Pride Dealer if damage is found.



WARNING! Do not attempt to open the battery charger case. If the battery charger does not appear to be working correctly, contact your authorised Pride Dealer.

WARNING! If the off-board battery charger is equipped with cooling slots, then do not attempt to insert objects through these slots.

WARNING! If your battery charger has not been tested and approved for outdoor use, then do not expose it to adverse or extreme weather conditions. If the battery charger is exposed to adverse or extreme weather conditions, then it must be allowed to adjust to the difference in environmental conditions before use indoors. Refer to the manual supplied with the battery charger for more information.

IV. BATTERIES AND CHARGING

Follow these easy steps to charge your batteries safely:

1. Position your scooter close to a standard electrical outlet.
2. Remove the key from the key switch.
3. Make certain that the manual freewheel lever is in the drive (down) position.
4. Plug the 3-pin charger power lead into the off-board charger port. See figures 5 and 9.
5. Extend the charger power lead and plug it into the electrical outlet. We recommend that you charge the batteries for 8 to 14 hours.
6. When the batteries are fully charged, unplug the charger power lead from the electrical outlet and then from the off-board charger port.

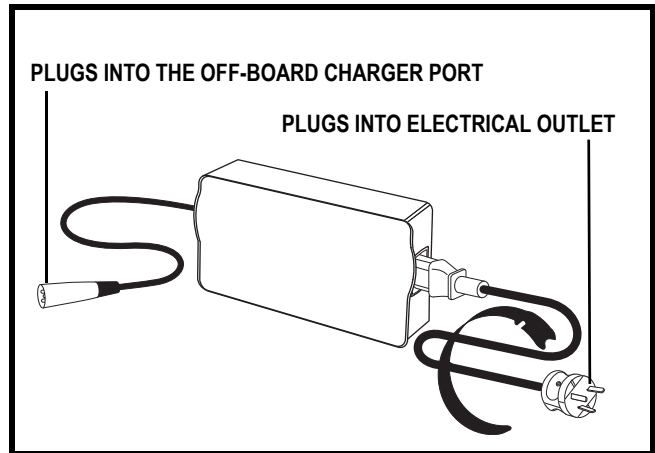

Figure 9. Off-board Charger

NOTE: The LED lights on the charger indicate different charger conditions at various times: charger power on, charging in progress and charging complete. Refer to the manual supplied with the charger for a complete explanation of these indicators.

NOTE: There is a charger inhibit function on your scooter. The scooter will not run and the battery condition meter will not operate while the batteries are charging.

FREQUENTLY ASKED QUESTIONS

How does the charger work?

When your scooter's battery voltage is low, the charger works harder and sends more electrical current to the batteries to bring up their charge. As the voltage of the batteries approaches a full charge, the charger sends less and less electrical current to the batteries. When the batteries are fully charged, the current sent to them from the charger is at nearly zero amperage. Therefore, when the charger is plugged in, it maintains the charge on your scooter's batteries, but does not overcharge them. We do not recommend that you charge your scooter's batteries for more than 24 consecutive hours.

What if my scooter's batteries won't charge?

- Ensure the red (+) and black (-) battery cables are connected properly to the battery terminals.
- Ensure both battery harnesses that extend from the batteries are plugged into their mating harness leading to the charger.
- Ensure both ends of the charger power lead are inserted fully.

Can I use a different charger?

Chargers are selected precisely for particular applications and are especially matched to the type, size and chemical formulation of specific batteries. For the safest and most efficient charging of your scooter's batteries, we recommend use of the charger supplied as original equipment with your Pride product only. Any charging method resulting in batteries being charged individually is especially prohibited.

How often must I charge the batteries?

Two major factors must be considered when deciding how often to charge your scooter's batteries:

- All day scooter use on a daily basis.
- Infrequent or sporadic scooter use.

IV. BATTERIES AND CHARGING

With these considerations in mind, you can determine just how often and for how long you should charge your scooter's batteries. We designed the battery charger so that it will not overcharge your scooter's batteries (do not charge them for more than 24 consecutive hours). However, you may encounter some problems if you do not charge your batteries often enough and if you do not charge them on a regular basis. Following the five guidelines below will provide safe and reliable battery operation and charging.

- If you use your scooter daily, charge its batteries as soon as you finish using it for the day. Your scooter will be ready each morning. We recommend that you charge your scooter's batteries for 8 to 14 hours after daily use.
- If you use your scooter once a week or less, charge its batteries at least once a week for 12 to 14 hours at a time.
- Keep your scooter's batteries fully charged.
- Avoid deeply discharging your scooter's batteries.

How can I get maximum range or distance per charge?

Rarely will you have ideal driving conditions—smooth, flat, hard driving surfaces with no wind or curves. You will often face hills, pavement cracks, uneven and loosely packed surfaces, curves and wind. All of these driving conditions affect the distance or running time per battery charge. Below are a few suggestions for obtaining the maximum range per battery charge.

- Always fully charge your scooter's batteries prior to your daily use.
- Maintain but do not exceed the psi/bar/kPa air pressure rating indicated on pneumatic tyres.
- Plan your route ahead to avoid as many hills, cracked, broken or soft surfaces as possible.
- Limit your baggage weight to essential items.
- Try to maintain an even speed while your scooter is in motion.
- Avoid stop-and-go driving.

What type and size of battery should I use?

We recommend deep-cycle batteries that are sealed and maintenance free. Both AGM and Gel-Cell are deep-cycle batteries that are similar in performance. Do not use wet-cell batteries, which have removable caps.



WARNING! Corrosive chemicals are contained in batteries. Use only AGM or Gel-Cell batteries to reduce the risk of leakage or explosive conditions.

NOTE: Sealed batteries are not serviceable. Do not remove the caps.

How do I change a battery in my scooter?



MANDATORY! Battery posts, terminals and related accessories contain lead and lead compounds. Wear goggles and gloves when handling batteries and wash hands after handling.

WARNING! Always use two batteries of the exact same type, chemistry and amp-hour (Ah) capacity. Refer to the specifications table in this manual and in the manual supplied with the battery charger for recommended type and capacities.



WARNING! Contact your authorised Pride Dealer if you have any questions regarding the batteries in your scooter.

WARNING! Do not replace the batteries while the scooter is occupied.

WARNING! The batteries on your scooter should only be serviced or replaced by an authorised Pride Dealer or a qualified technician.



PROHIBITED! Keep tools and other metal objects away from the battery terminals. Contact with tools can cause electrical shock.

IV. BATTERIES AND CHARGING

You may need the following to change your batteries:

- metric/standard socket set and ratchet
- adjustable spanner

To change the batteries in your scooter:

1. Remove the seat and the rear shroud. See VII. “Disassembly and Assembly.”
2. Disconnect the battery tie-down straps.
3. Disconnect the battery harnesses from the rear electronics module.
4. Disconnect the battery cables from the battery terminals.
5. Remove the old batteries.
6. Place a new battery in each battery well.
7. Connect the red battery cables to the positive (+) battery terminals.
8. Connect the black battery cables to the negative (-) battery terminals.
9. Reconnect the battery harnesses to the rear electronics module.
10. Reconnect the battery tie-down straps.
11. Reinstall the rear shroud and the seat.

NOTE: If you encounter a damaged or cracked battery, immediately enclose it in a plastic bag and contact your local waste disposal agency or your authorised Pride Dealer for instructions on disposal and battery recycling, which is our recommended course of action.

Why do my new batteries seem weak?

Deep-cycle batteries employ a different chemical technology than is used in car batteries, nickel-cadmium batteries (nicads) or in other common battery types. Deep-cycle batteries are specifically designed to provide power, drain down their charge and then accept a relatively quick recharge.

We work closely with our battery manufacturer to provide batteries that best suit your scooter’s specific electrical demands. Fresh batteries arrive daily at Pride and are shipped fully charged to our customers. During shipping, the batteries may encounter temperature extremes that may influence their initial performance. Heat diminishes the charge on the battery; cold slows the available power and extends the time needed to recharge the battery.

It may take a few days for the temperature of your scooter’s batteries to stabilise and adjust to their new room or ambient temperature. More importantly, it takes a few charging cycles (a partial drain followed by a full recharge) to establish the critical chemical balance that is essential to a deep-cycle battery’s peak performance and long life.

Follow these steps to properly break in your scooter’s new batteries for maximum efficiency and service life:

1. Fully recharge any new battery prior to its initial use. This charging cycle brings the battery up to about 88% of its peak performance level.
2. Operate your new scooter in familiar and safe areas. Drive slowly at first and do not travel too far from your home or familiar surroundings until you have become accustomed to your scooter’s controls and have properly broken in your scooter’s batteries.
3. Fully recharge the batteries. They should be at over 90% of their peak performance level.
4. Operate your scooter again.

IV. BATTERIES AND CHARGING

How can I ensure maximum battery life?

Fully charged deep-cycle batteries provide reliable performance and extended battery life. Keep your scooter's batteries fully charged whenever possible. Batteries that are regularly and deeply discharged, infrequently charged or stored without a full charge may be permanently damaged, causing unreliable performance and limited service life.

What about public transport?

If you intend to use public transport with your scooter, you must contact the transportation dealer in advance to determine their specific requirements.

V. OPERATION

BEFORE GETTING ON YOUR SCOOTER

- Have you fully charged the batteries? See IV. “Batteries and Charging.”
- Is the manual freewheel lever in the drive (down) position? Never leave the manual freewheel lever pulled up unless you are manually pushing your scooter.

GETTING ONTO YOUR SCOOTER

1. Make certain that the key is removed from the key switch.



WARNING! Never attempt to get onto or off your scooter without first removing the key from the key switch. This will prevent the scooter from moving if accidental throttle control lever contact is made.

2. Stand at the side of your scooter.
3. Push down on the seat rotation lever and rotate the seat until it is facing you.
4. Make certain that the seat is fixed securely in position.
5. Position yourself comfortably and securely in the seat.
6. Push down on the seat rotation lever and rotate the seat until you are facing forward.
7. Make certain that the seat is fixed securely in position.
8. Make certain that your feet are safely on the floorboard.

PRE-RIDE ADJUSTMENTS AND CHECKS

- Is the seat at the proper height?
- Is the seat fixed securely in place?
- Is the tiller at a comfortable setting and locked securely in place? See VI. “Comfort Adjustments.”
- Is the key fully inserted into the key switch and turned clockwise to the “on” position? See III. “Your Scooter.”
- Does the scooter’s horn work properly?
- Is your proposed path clear of people, pets and obstacles?
- Have you planned your route to avoid adverse terrain and as many inclines as possible?

OPERATING YOUR SCOOTER

WARNING! The following can adversely affect steering and stability while operating your scooter:



- Holding onto or attaching a leash to walk your pet
- Carrying passengers (including pets)
- Hanging any article from the tiller
- Towing or being pushed by another motorized vehicle

WARNING! Keep both hands on the tiller and your feet on the floorboard at all times while operating your scooter. This driving position gives you the most control over your vehicle.

- Set the speed adjustment dial to your desired speed.
- Press your thumb against the appropriate side of the throttle control lever.
- The electromechanical disc park brake automatically disengages and the scooter accelerates smoothly to the speed you preselected with the speed adjustment dial.
- Pull on the left handgrip to steer your scooter to the left.
- Pull on the right handgrip to steer your scooter to the right.
- Move the tiller to the centre position to drive straight ahead.
- To stop, slowly release the throttle control lever. The electronic brakes will automatically engage when your scooter comes to a stop.

NOTE: Your scooter’s reverse speed is slower than that of the forward speed you preset with the speed adjustment dial.

V. OPERATION

GETTING OFF OF YOUR SCOOTER

1. Bring your scooter to a complete stop.
2. Remove the key from the key switch.
3. Push down on the seat rotation lever and rotate the seat until you are facing toward the side of your scooter.
4. Make certain that the seat is fixed securely in position.
5. Carefully and safely get out of the seat and stand to the side of your scooter.
6. You can leave the seat facing to the side to facilitate boarding your scooter next time.

POWER DOWN TIMER FEATURE

Your scooter is equipped with an energy saving automatic power down timer feature designed to preserve your scooter's battery life. If you mistakenly leave the key in the key switch and in the "on" position but do not use your scooter for approximately 20 minutes, the scooter's controller shuts down automatically. Although the controller is shut down and the scooter will not move, power will still be supplied to the scooter's lighting system.

If the power down timer feature takes effect, perform the following steps to resume normal operation:

1. Turn the key to the "off" position.
2. Turn the key back to the "on" position.

VI. COMFORT ADJUSTMENTS

TILLER ANGLE ADJUSTMENT



WARNING! Remove the key from the key switch before adjusting the tiller or the seat. Never attempt to adjust the tiller or the seat while the scooter is in motion.

Your scooter is equipped with a pivoting tiller that allows adjustment to several positions.

1. Lift the tiller adjustment lever. See figure 10.
2. Move the tiller to a comfortable position.
3. Release the tiller adjustment lever to secure the tiller in position.

SEAT ROTATION ADJUSTMENT

The seat rotation lever secures the seat in one of four positions. See figure 11.

1. Push the seat rotation lever down to disengage the seat.
2. Rotate the seat to the desired position.
3. Release the seat rotation lever to fix the seat securely in place.

FRONT-TO-BACK SEAT ADJUSTMENT

You can reposition the scooter's seat forward or rearward to one of three settings to adjust the distance between the seat and the tiller. See figure 11.

1. Remove the seat from your scooter. See VII. "Disassembly and Assembly."
2. Remove the four bolts that fasten the seat to the seat platform.
3. Align the seat platform with the desired set of holes on the seat.
4. Install the four bolts securely.

ARMREST WIDTH ADJUSTMENT

The armrests can be adjusted inward or outward. See figure 12.

1. Loosen the armrest adjustment knobs at the back of the seat frame.
2. Slide the armrests in or out to the desired width.
3. Tighten the armrest adjustment knobs.

The armrests also pivot upward to make getting onto and off of your scooter easier.

ARMREST HEIGHT ADJUSTMENT

The height of both armrests can be adjusted upward or downward. See figure 12.

1. Loosen the two setscrews located on the armrest receiver.
2. Raise or lower the armrest to the desired height.
3. Tighten the setscrews to secure the armrest.

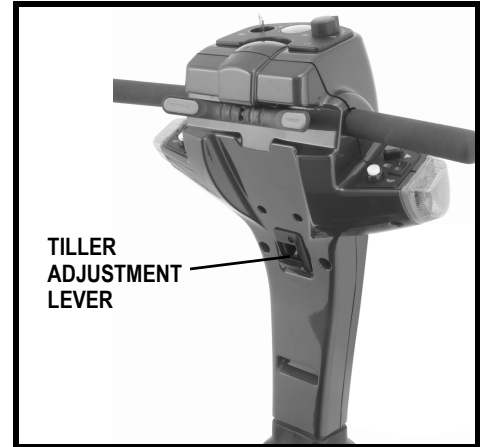

Figure 10. Tiller Adjustment Lever

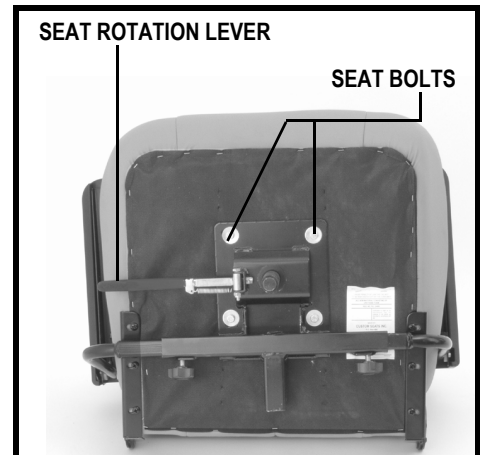

Figure 11. Seat Adjustments

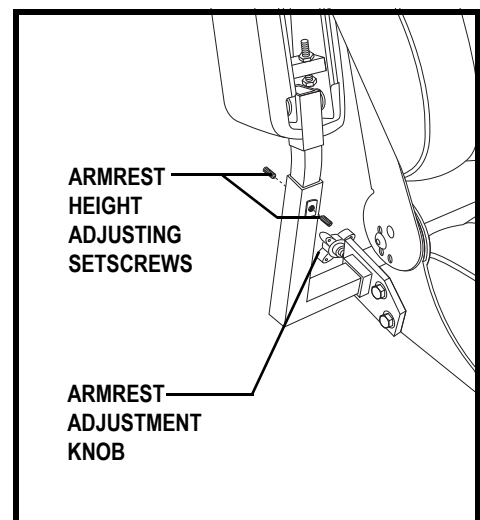

Figure 12. Armrest Adjustments

VI. COMFORT ADJUSTMENTS

SEATBACK ADJUSTMENT

The seatback may be positioned to four different angles: 90°, 100°, 102° and 105°. See figure 13.

To adjust the seatback angle:

1. Loosen and remove the adjustment screw from the seatback hinge on both sides of the seat.
2. Reposition the seatback to the desired angle.
3. Align the adjustment holes from the upper and lower hinge, so the adjustment screw can easily pass through.
4. Reinsert both adjustment screws and tighten.

SEAT HEIGHT ADJUSTMENT

The seat can be repositioned to different heights. See figure 14.

1. Remove the seat and rear shroud from your scooter. See VII. "Disassembly and Assembly."
2. Loosen the nut and remove it from the bolt, and remove the bolt and washers from the lower seat post.
3. Raise or lower the upper seat post to the desired seat height.
4. While holding the upper seat post at that height, match up the holes in the upper seat post with those of the lower seat post.
5. Reinstall the bolt, washers and nut to secure the seat post.

NOTE: Ensure both washers have been reinstalled before fully tightening the nut.

6. Reinstall the rear shroud and the seat.

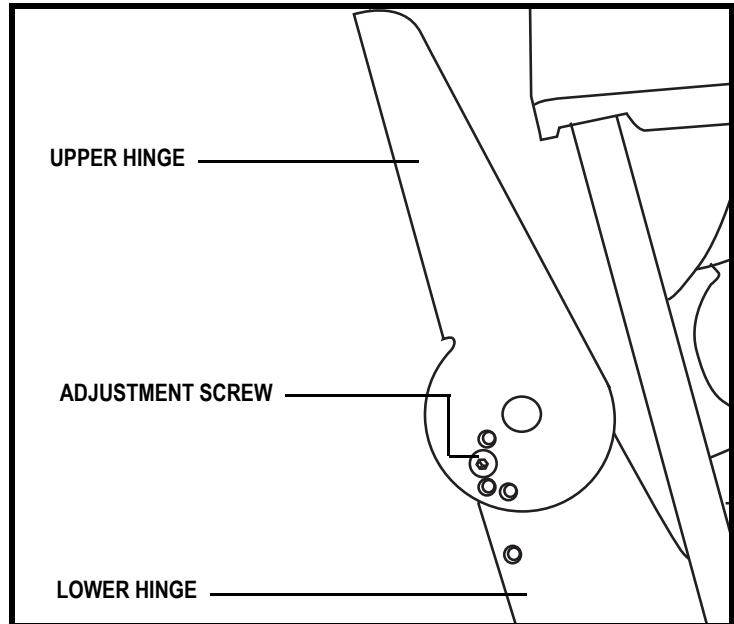

Figure 13. Seatback Hinge

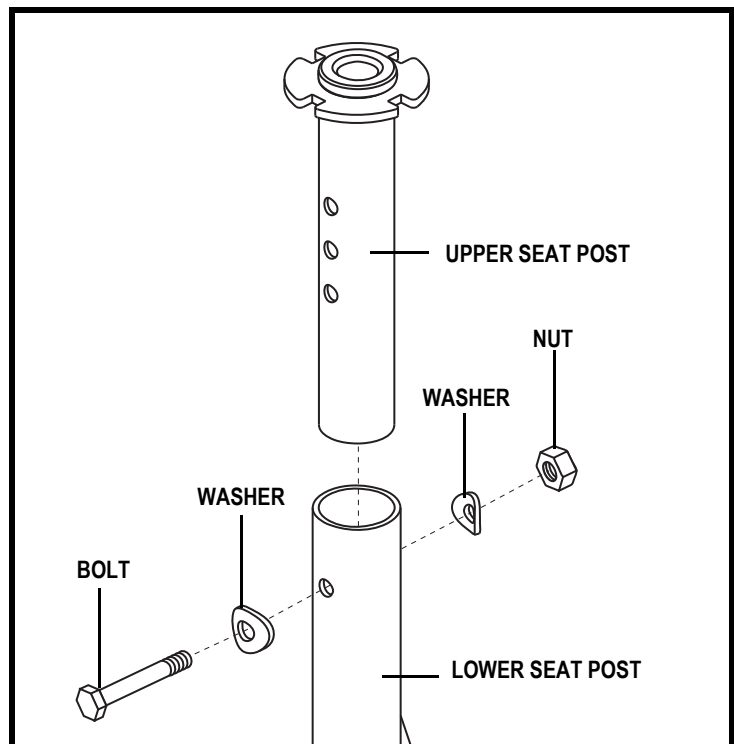

Figure 14. Seat Height Adjustment

VI. COMFORT ADJUSTMENTS

POWER SEAT ADJUSTMENT

Your scooter may be equipped with a power seat. The power seat actuator is designed to raise or lower the seat with minimal effort on the part of the operator. The power seat switch is located on the control console.

WARNING! The power seat is intended for operation only while your scooter is stationary and on a level surface. Its purpose is to aid you in reaching objects. Drive your scooter only with the power seat in the lowest position. Driving the scooter with the power seat elevated could cause instability in the scooter, resulting in a tip or a fall.



Strict adherence to the following safety rules is vital to your safety:

- Operate the power seat only while completely stationary on level ground.
- Do not press the throttle control lever and the power seat switch at the same time.
- Do not operate your scooter with the power seat elevated. Operate the scooter only with the power seat fully retracted (in the lowest position).
- Never place your scooter in freewheel mode with the power seat elevated.
- Use extreme caution when reaching for objects with your power seat elevated. Do not overextend or attempt to pick up objects that might affect your balance.
- Do not attempt to raise or lower the seat while in motion.

Before operating the power seat, ensure your scooter is level and stationary and the speed adjustment dial is set to the slowest setting.

To operate the power seat:

1. Press and hold the upper part of the power seat switch to raise the seat. Release the switch when you have attained your desired height or upon reaching the highest position.
2. Press and hold the lower part of the power seat switch to lower the seat. Release the switch when you have attained your desired height or upon reaching the lowest position.

NOTE: The scooter must be stopped in order for the power seat to be operated. If the power seat switch is pressed while the scooter is in motion, the scooter will slow and come to a stop. The scooter may also produce a fault code. If a fault code occurs, you will need to turn the scooter's power off, then back on again before proceeding.

Instances may occur when the power seat is raised to reach something or get a better vantage point and not returned to its lowest position before operating the scooter again. Depending on how high the power seat is raised, your scooter's speed will be reduced when operating the scooter.

Elevating the power seat to approximately one-half its maximum height limits your scooter's speed to half that set with the speed adjustment dial. If the power seat is elevated to approximately three-quarters its maximum height, the scooter will not move if the throttle control lever is pressed. The power seat must be lowered to slightly under three-quarters of its maximum height in order to drive the scooter again. The scooter cannot be driven at full speed until the scooter's seat is lowered to approximately one-half its maximum height.

It is strongly recommended that the scooter not be operated with the power seat elevated.

VI. COMFORT ADJUSTMENTS

POSITIONING BELT

Your scooter seat may be equipped with an auto-type positioning belt that can be adjusted for operator comfort. The positioning belt is designed to help support the operator so that he or she does not slide down or forward in the seat. The positioning belt is not designed for use as a restraining device.

To install the positioning belt (if required):

1. Remove the seat from your scooter.
2. Place the seat upside down so that you can see the bottom of the seat base. **See figure 11.**
3. Use a spanner to remove the two back bolts on the outermost part of the rear seat.
4. Insert the bolt through the appropriate ends of the positioning belt and then reinstall the bolts and belt back into the seat bottom.
5. Tighten the bolts.

To adjust the positioning belt for operator comfort:

1. Insert the metal tab on the right side of the belt into the plastic housing on the opposite strap until you hear a “click.” **See figure 15.**
2. Pull the strap on the right side of the belt until it is secure, but not so tight as to cause discomfort.

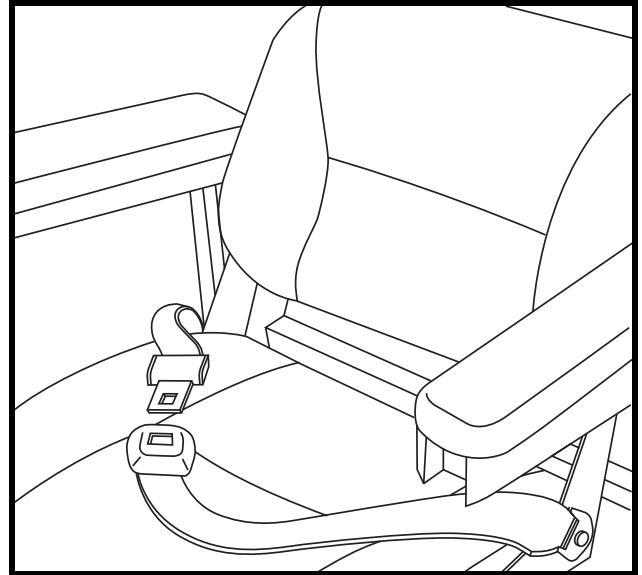

Figure 15. Positioning Belt

MANDATORY! Make sure the positioning belt is properly secured to the scooter and is adjusted for operator comfort before each use.



MANDATORY! Inspect the positioning belt for loose or damaged parts before each use of the scooter. If you discover a problem, contact your authorised Pride Dealer for maintenance and repair.

VII. DISASSEMBLY AND ASSEMBLY

DISASSEMBLY

You can disassemble the scooter into several pieces: the seat, the front section, the rear section, the rear shroud, the basket and the batteries. See figure 16. No tools are required to disassemble or assemble your scooter, but keep in mind that the disassembled sections of the scooter take up more floor space than the assembled unit. Always disassemble or assemble your scooter on a level, dry surface with sufficient room for you to work and move around your scooter—about 2 metres (5 feet) in all directions. Remember that some scooter components are heavy and you may need assistance when lifting them.

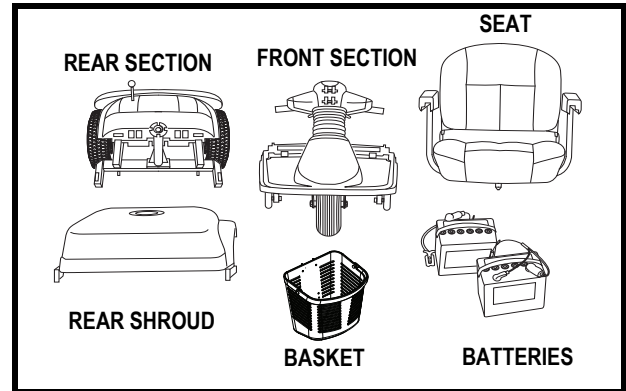

Figure 16. The Scooter Disassembled



WARNING! Do not lift beyond your physical capability. Ask for assistance when necessary while disassembling or assembling your scooter.

To disassemble the scooter:

1. Place the manual freewheel lever in the drive (down) position.
2. Lift the seat straight up and off the scooter. See figure 17.
3. Gently lift the rear shroud off of the scooter. See figure 18.
4. Disconnect the battery tie-down strap that holds the batteries in place.
5. Unplug both black and white 2-pin battery harnesses. See figure 19.
6. Unplug the front-to-rear harness from its mating plug. See figure 20.



WARNING! Failure to unplug both battery harnesses and the front-to-rear harness prior to frame separation could result in permanent damage to the scooter.

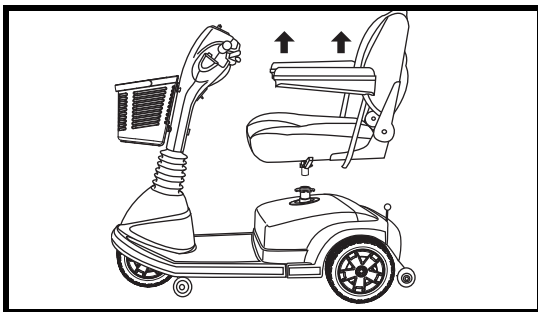

Figure 17. Seat Removal

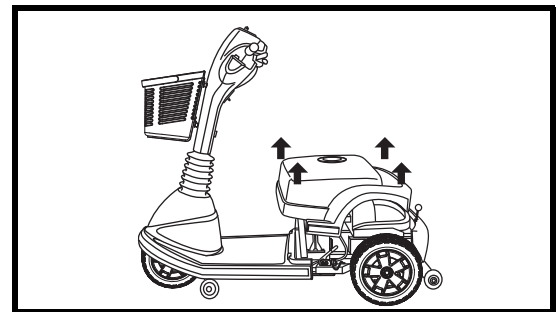

Figure 18. Rear Shroud Removal

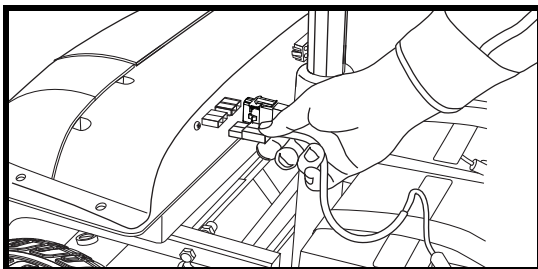

Figure 19. Disconnecting The Battery Harnesses

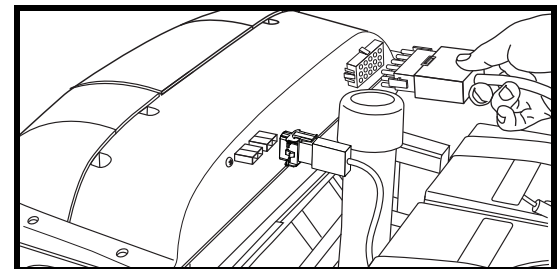

Figure 20. Disconnecting The Front-To-Rear Harness

VII. DISASSEMBLY AND ASSEMBLY

NOTE: There is no need to disconnect the motor harness when disassembling the scooter. See figure 21.

7. Lift both batteries off the scooter. See figure 22.
8. Push the locking cam levers forward to the unlocked position and remove the ball detent pins. See figures 23 and 24.
9. Remove the frame handle ball detent pin. See figure 25.
10. Gently slide the two sections of the scooter apart. See figure 26.
11. Grab the hand grip on the tiller, pull upward on the tiller adjustment lever and fully lower the tiller down to the centre of the scooter chassis.

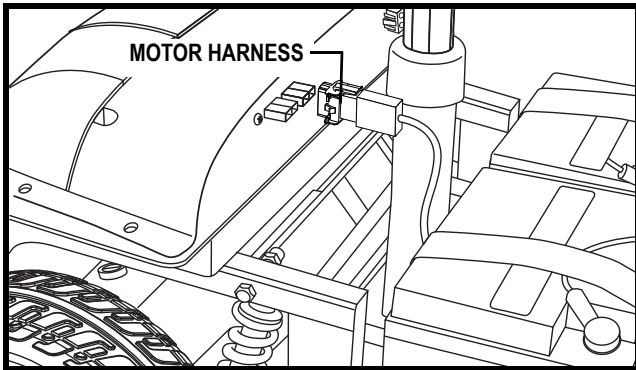

Figure 21. Motor Harness

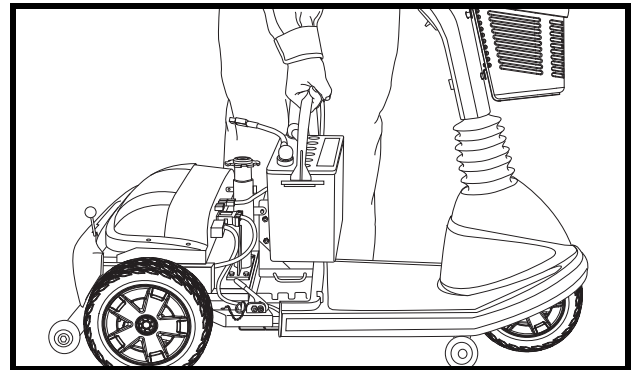

Figure 22. Battery Removal

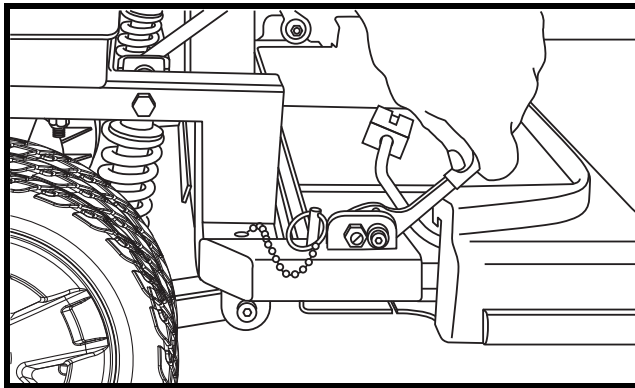

Figure 23. Locking Cam Levers (Unlocked Position)

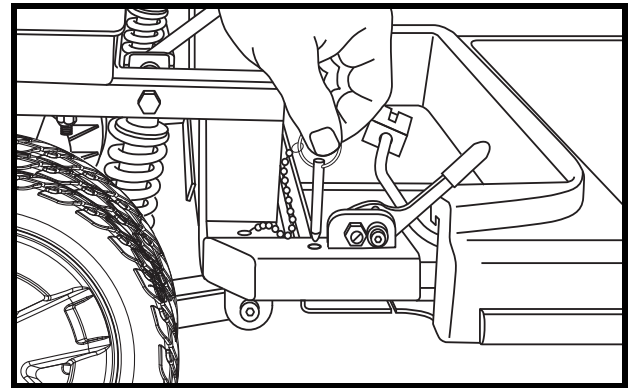

Figure 24. Frame Lock-up Ball Detent Pins

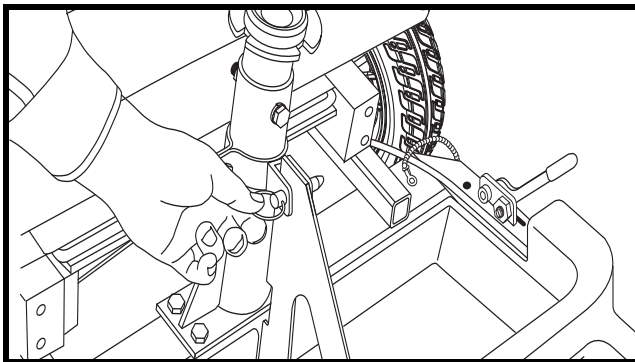

Figure 25. Frame Handle Ball Detent Pin

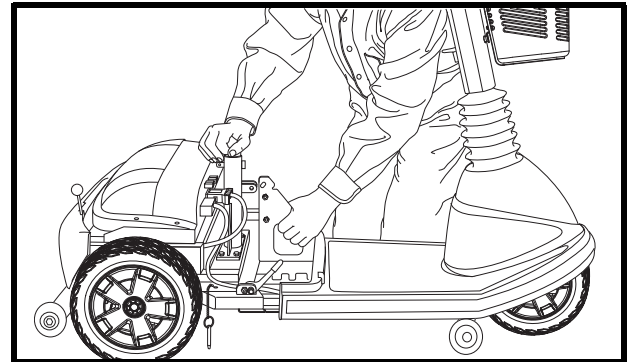

Figure 26. Frame Separation

VII. DISASSEMBLY AND ASSEMBLY

ASSEMBLY

NOTE: Raise the tiller before starting to reassemble the scooter.

1. Place the manual freewheel lever in the drive (down) position.
2. Position the front and rear sections next to each other.
3. Tilt the rear end to a horizontal position and insert the longer tube of the front end into the rear section first; make sure that the locking cam levers are in the unlocked (forward) position and the ball detent pins are removed.
4. Slide the two sections of the unit together until the front half reaches its insertion limit.
5. Secure the front and rear sections with the ball detent pins.
6. Push the locking cam levers back to their locked (upward) position.
7. Replace the frame handle ball detent pins.
8. Plug the front-to-rear harness into its mating plug.
9. Put the batteries in place and plug both black and white 2-pin battery harnesses into their mating plugs.
10. Reconnect the battery tie-down strap.
11. Reinstall the rear shroud.
12. Reinstall the seat.
13. Rotate the seat until it is securely in place.

VIII. BASIC TROUBLESHOOTING

Any electromechanical device occasionally requires some troubleshooting. However, most of the problems that may arise can usually be solved with a bit of thought and common sense. Many of these problems occur because the batteries are not fully charged or because the batteries are worn down and can no longer hold a charge.

DIAGNOSTIC FLASH CODES

The diagnostic flash codes for your scooter are designed to help you perform basic troubleshooting quickly and easily. A diagnostic flash code flashes from the status LED in the event one of the conditions listed below develops.

NOTE: *Your scooter will not run unless the flash code condition is resolved and the scooter has been turned off, then turned back on.*

FLASH CODE	CONDITION	SOLUTION
■ ■ (2)	Battery voltage is too low to operate the scooter.	Charge fully until charger and any meters indicate completion.
■ ■ ■ ■ (3)	Battery voltage is too high to operate the scooter.	Contact your authorised Pride Dealer for assistance.
■ ■ ■ ■ ■ ■ (5)	Solenoid brake trip. The manual freewheel lever may be in the freewheel position.	Remove the key, then push the manual freewheel lever to the drive position, restart your scooter.
■ ■ ■ ■ ■ ■ ■ ■ (6)	Throttle trip. The throttle control lever may have been depressed while inserting the key.	Release the throttle control lever completely, then reinsert the key.
■ ■ ■ ■ ■ ■ ■ ■ ■ ■ (7)	Throttle trip. The throttle control lever may have been depressed while inserting the key.	Contact your authorised Pride Dealer for assistance.
■ ■ ■ ■ ■ ■ ■ ■ ■ ■ ■ ■ (8)	The scooter's motor is disconnected.	Contact your authorised Pride Dealer for assistance.
■ ■ ■ ■ ■ ■ ■ ■ ■ ■ ■ ■ ■ ■ (9)	Possible controller trip. You may be attempting to install the battery while the key is inserted or the motor controller may be in overheat protective mode.	Shut down your scooter for a minimum of several minutes to allow the controller to cool. Or, try reinserting the key into the key switch.

What if all the systems on my scooter seem to be “dead”?

- Make certain that the key is in the “on” position.
- Check that the batteries are fully charged. See IV. “Batteries and Charging.”
- Push in the main circuit breaker reset button. See III. “Your Scooter”
- Make certain that both battery harnesses are firmly connected to the electronics module and to the battery terminals. See VII. “Disassembly and Assembly.”
- Make sure that the front-to-rear harness is firmly connected to the electronics module. See VII. “Disassembly and Assembly.”
- Check the fuses. See IX. “Care and Maintenance” for fuse replacement.
- Be sure the power down timer feature has not been activated. See V. “Operation.”

VIII. BASIC TROUBLESHOOTING

What if the motor runs but my scooter does not move?

- With the key turned to the “on” position, check the status LED. If the LED flashes three times, pauses briefly, then flashes two times, this is the manual freewheel lever code meaning your scooter is in freewheel mode.
- When the manual freewheel lever is pulled up, the brakes are disengaged and all power to the transaxle is cut.
- Push down the manual freewheel lever to restore normal operation to your scooter. See III. “Your Scooter.”

What if the main circuit breaker repeatedly trips?

- Charge the scooter’s batteries more frequently. See IV. “Batteries and Charging.”
- If the problem continues, have both of your scooter’s batteries load tested by your authorised Pride Dealer.
- You may also perform the load test yourself. Battery load testers are available at most automotive parts stores.
- Follow the directions supplied with the load tester.
- See IV. “Batteries and Charging” for information about your scooter’s battery type.

What if the battery condition meter dips way down and the motor surges or hesitates when I press my scooter’s throttle control lever?

- Fully charge your scooter’s batteries. See IV. “Batteries and Charging.”
- Have your authorised Pride Dealer load test each battery.
- Or, see the previous troubleshooting question for load testing the batteries yourself.

If you experience any problems with your scooter that you are not able to solve, immediately contact your authorised Pride Dealer for information, maintenance and service.

IX. CARE AND MAINTENANCE

Your scooter requires a minimal amount of care and maintenance. If you do not feel confident in your ability to perform the maintenance listed below, you may schedule inspection and maintenance at your authorised Pride Dealer. The following areas require periodic inspection and/or care and maintenance.

TYRE PRESSURE

- If equipped with pneumatic tyres, always maintain the psi/bar/kPa air pressure rating indicated on each tyre.



WARNING! It is critically important that the psi/bar/kPa air pressure rating be maintained in pneumatic tyres at all times. Do not underinflate or overinflate your tyres. Low pressure may result in loss of control and overinflated tyres may burst. Failure to maintain the psi/bar/kPa air pressure rating indicated on pneumatic tyres at all times may result in tyre and/or wheel failure.

- Regularly inspect your scooter's tyres for signs of wear.

EXTERIOR SURFACES

Bumpers, tyres and trim can benefit from an occasional application of rubber or vinyl conditioner.



WARNING! Do not use a rubber or vinyl conditioner on the scooter's vinyl seat, floorboard or tyre tread, as they will become dangerously slippery.

CLEANING AND DISINFECTION

- Use a damp cloth and mild, non-abrasive cleanser to clean the plastic and metal parts of your scooter. Avoid using products that may scratch the surface of your scooter.
- If necessary, clean your product with an approved disinfectant. Make sure the disinfectant is safe for use on your product before application.



WARNING! Follow all safety instructions for the proper use of the disinfectant and/or cleaning agent before applying it to your product. Failure to comply may result in skin irritation or premature deterioration of upholstery and/or scooter finishes.

BATTERY TERMINAL CONNECTIONS

- Make certain that the terminal connections remain tight and uncorroded.
- The batteries must sit flat in the battery wells.
- The battery terminals should face the rear of the scooter.

AXLE BEARINGS AND THE MOTOR/TRANSAXLE ASSEMBLY

These items are all prelubricated, sealed and require no subsequent lubrication.

MOTOR BRUSHES

The motor brushes are housed inside of the motor transaxle/assembly. They should be inspected periodically for wear by your authorised Pride Dealer.

CONSOLE, CHARGER AND REAR ELECTRONICS

- Keep these areas away from moisture.
- Before operating your scooter, allow any of these areas to dry thoroughly if they have been exposed to moisture.

IX. CARE AND MAINTENANCE

WHEEL REPLACEMENT

If your scooter is equipped with pneumatic tyres and you have a flat tyre, you can have the tube replaced. If your scooter is equipped with a solid tyre insert, either the solid insert or the entire wheel must be replaced depending on the model. Contact your authorised Pride Dealer for information regarding replacement wheels for your scooter.

WARNING! Wheels on your scooter should only be serviced/replaced by an authorised Pride Dealer or qualified technician.

WARNING! Be sure that the key is removed from the key switch and the scooter is not in freewheel mode before performing this procedure.

WARNING! When changing a tyre, remove only the centre lug nut, then remove the wheel. If any further disassembly is required, deflate the tyre completely or it may explode.

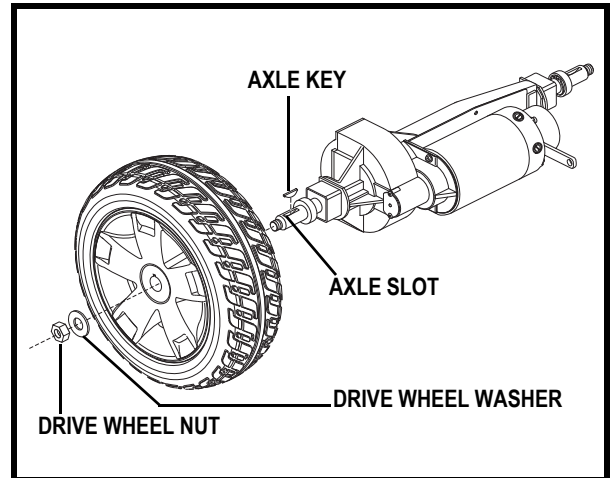

Figure 27. Drive Wheel Removal

Follow these easy steps for a quick and safe repair of solid tyres:

1. Remove the key from the key switch.
2. Elevate the side of the scooter of which you are removing the tyre. Place wooden blocks under the frame to elevate the scooter.
3. Remove the drive wheel nut and washer from the axle. See figure 27.
4. Pull the wheel off the axle.
5. Slide the new wheel back onto the axle. Make sure that the axle key is in the axle slot. See figure 27.

WARNING! Failure to ensure that the axle key is properly installed into the axle slot when mounting the wheel can result in electronic brake failure, personal injury and/or product damage.

6. Reinstall the drive wheel nut and washer onto the axle and tighten.

WARNING! Make sure both the nut and washer are reinstalled and tightened properly.

7. Remove the blocks from beneath the scooter.

IX. CARE AND MAINTENANCE

WIRING HARNESSES

- Regularly check all wiring connections.
- Regularly check all wiring insulation, including the charger power lead, for wear or damage.
- Have your authorised Pride Dealer repair or replace any damaged connector, connection or insulation that you find before using your scooter again.



PROHIBITED! Even though the scooter has passed the necessary testing requirements for ingress of liquids, you should keep electrical connections away from sources of dampness, including direct exposure to water or bodily fluids and incontinence. Check electrical components frequently for signs of corrosion and replace as necessary.

ABS PLASTIC SHROUDS

- The front tiller shroud, front shroud and the rear shroud are formed from durable ABS plastic and are coated with an advanced formula urethane paint.
- A light application of car wax will help the shrouds retain their high gloss.

LIGHT BULB REPLACEMENT

The scooter's light bulbs are easily replaceable. Do not use regular automotive-type 12-volt light bulbs; your scooter is equipped with a 24-volt electrical system. Replacement light bulbs can be purchased from your authorised Pride Dealer.

NOTE: Use only 24-volt light bulbs.

1. Remove the light cover.
2. Gently remove the bulb by pulling it straight out.
3. Insert a new bulb of the same wattage.
4. Replace the light cover.

FUSE REPLACEMENT

In the event a fuse should cease to work:

1. Remove the fuse by pulling it out of its slot.
2. Examine the fuse to be sure it is blown. See figures 28 and 29.
3. Insert a new fuse of the proper rating.



WARNING! The replacement fuse must exactly match the rating of the fuse being replaced. Failure to use properly rated fuses may cause damage to the electrical system.

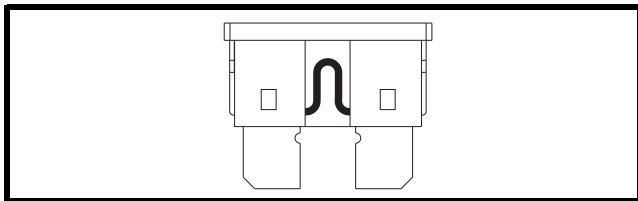

Figure 28. Working Fuse

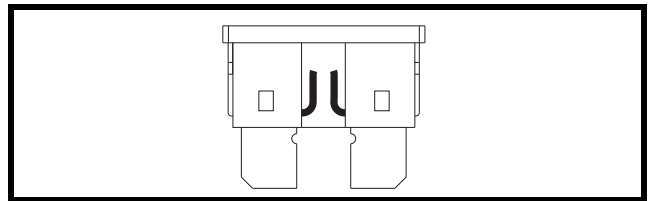

Figure 29. Blown Fuse (Replace)

IX. CARE AND MAINTENANCE

NYLON LOCK NUT REPLACEMENT

Any nylon insert lock nut removed during the periodic maintenance, assembly or disassembly of the scooter must be replaced with a new nut. Nylon insert lock nuts should not be reused as it may cause damage to the nylon insert, resulting in a less secure fit. Replacement nylon insert lock nuts are available at local hardware stores or through your authorised Pride Dealer.

STORING YOUR SCOOTER

If you plan on not using your scooter for an extended period of time, it is best to:

- Fully charge its batteries prior to storage.
- Disconnect the batteries from the scooter.
- Store your scooter in a warm, dry environment.
- Avoid storing your scooter where it will be exposed to temperature extremes.



WARNING! Always protect batteries from freezing temperatures and never charge a frozen battery. Charging a frozen battery may result in damage to the battery.

Batteries that are regularly and deeply discharged, infrequently charged, stored in extreme temperatures or stored without a full charge may be permanently damaged, causing unreliable performance and limited service life. It is recommended that you charge the scooter batteries periodically throughout periods of prolonged storage to ensure proper performance.

You may wish to place several boards under the frame of your scooter to raise it off of the ground during periods of prolonged storage. This takes the weight off the tyres and reduces the possibility of flat spots developing on the areas of the tyres contacting the ground.

DISPOSAL OF YOUR SCOOTER

Your scooter must be disposed of according to applicable local and national statutory regulations. Contact your local waste disposal agency or authorised Pride Dealer for information on proper disposal of packaging, metal frame components, plastic components, electronics, batteries, neoprene, silicone and polyurethane materials.

X. WARRANTY

LIFETIME WARRANTY

Structural frame components, including: platform, fork, seat post and frame welds.

TWO-YEAR LIMITED WARRANTY

Drivetrain, including: transaxle, motor and brake.

ONE-YEAR LIMITED WARRANTY

All electrical parts, including controllers and battery chargers, are covered for one year under warranty. Any attempt to open or dismantle these parts will lead to this warranty being void.

BATTERIES

Batteries are covered by a twelve-month warranty from the original manufacturer.

NOT COVERED UNDER WARRANTY

The following are classed as wear items, which may, under normal wear and tear, require replacing. These items are not therefore covered under warranty: tyres, lap belts, bulbs, upholstery, plastic shrouds, motor brushes and fuses. Warranty will also be refused if damage is deemed to have been caused through misuse or accident for which Pride Mobility Products Ltd. cannot be deemed responsible.

NOTE: Pride Mobility Products Ltd. provides parts only under warranty. Your Pride Dealer is responsible for labour and service. Please contact your Pride Dealer for information about these services and for any applicable charges.

APPENDIX I - SPECIFICATIONS

MAXIMA SPECIFICATIONS	
Model Numbers	3-wheel: SC900, 4-wheel SC940
Overall Length²	3-wheel: 117.6 cm (46.3 in.), 4-wheel: 119.4 cm (47 in.)
Overall Width²	64.8 cm (25.5 in.)
Total Weight Without Batteries	3-wheel: 77.5 kg (171 lbs.), 4-wheel: 80 kg (176 lbs.)
Heaviest Piece When Disassembled	Rear Frame: 32 kg (70 lbs.)
Turning Radius²	3-wheel: 132.1 cm (52 in.) 4-wheel: 137.2 cm (54 in.)
Speed (maximum)	Variable up to 9 km/h (5.6 mph)
Range Per Charge^{1,4}	With NF-22 batteries: 3-wheel - Up to 29.11 km (18.09 miles) 4-wheel - Up to 25.75 km (16 miles) With U-1 batteries: Up to 15.45 km (9.6 miles) ⁶
Ground Clearance²	8.1 cm (3.2 in.)
Weight Capacity	227 kg, 36 stone (500 lbs.)
Standard Seating	Type: DX contour medium black Dimensions: 56 cm (22 in.) width x 46 cm (18 in.) depth x 47 cm (18.5 in.) height Material: Grey, Beige or Black Vinyl or Grey Fabric
Standard Seat Weight	19 kg (41 lbs.)
Drive System	Rear-wheel drive, sealed transaxle with a 24-volt DC motor
Dual Braking System	Regenerative and electromechanical
Tyres	Type: solid; front: 7.5 cm x 25 cm (3 in. x 10 in.), rear: 10 cm x 25 cm (4 in. x 10 in.)
Battery Requirements³	Type: Two 12-volt deep-cycle Size: (U-1) 31-36 Ah, (NF-22) 55 Ah
Battery Weight⁵	Approximately: (U-1) 11 kg (24.5 lbs.) each, (NF-22) 17 kg (38 lbs.) each
Battery Charger	Off-board charger

¹ Varies with base model, user weight, terrain type, battery amp hour rating (Ah), battery charge, battery condition, motors, controller type, tyre type and tyre condition. This specification can be subject to a variance of + 10%, -5%.

² Due to manufacturing tolerances and continued product improvement, this specification can be subject to variance of (+ or -) 3%.

³ AGM or Gel-Cell type required. See VI. "Batteries and Charging."

⁴ Tested in accordance with ANSI/RESNA, WC Vol 2, Section 4 & ISO 7176-4 standards. Results derived from theoretical calculation based on battery specifications and drive system performance. Test conducted at maximum weight capacity.

⁵ Battery weight may vary based on battery manufacturer.

⁶ Test conducted on SC900 at maximum weight capacity.

NOTE: This product conforms to all applicable ANSI-RESNA testing requirements and ISO 7176 EN12184 standards. All specifications subject to change without notice.

APPENDIX I - SPECIFICATIONS

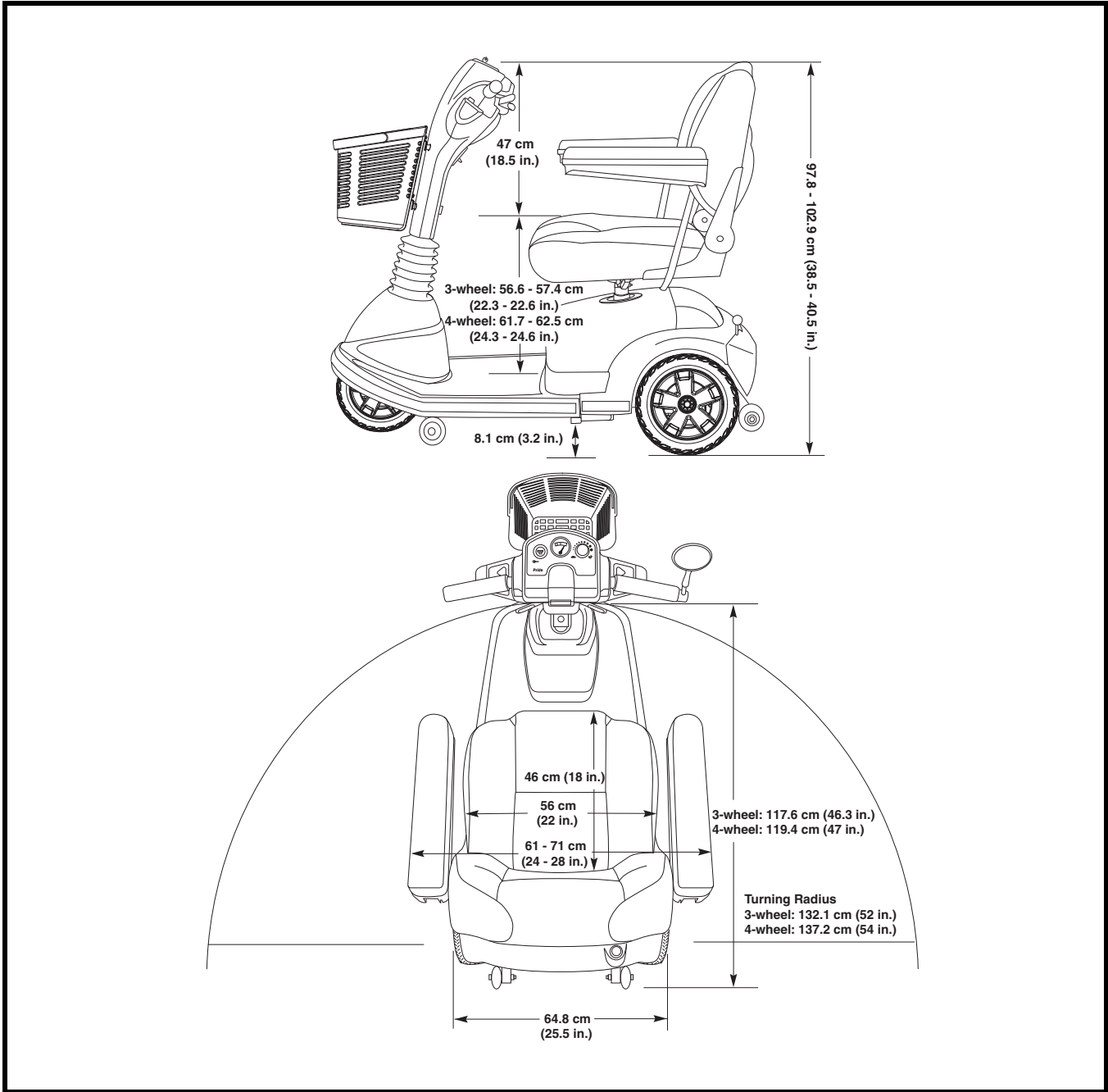

Figure 30. Scooter Dimensions

NOTES



Pride[®]
Mobility Products Ltd.

*32 Wedgwood Road
Bicester, Oxon OX26 4UL*

www.pridemobility.com