

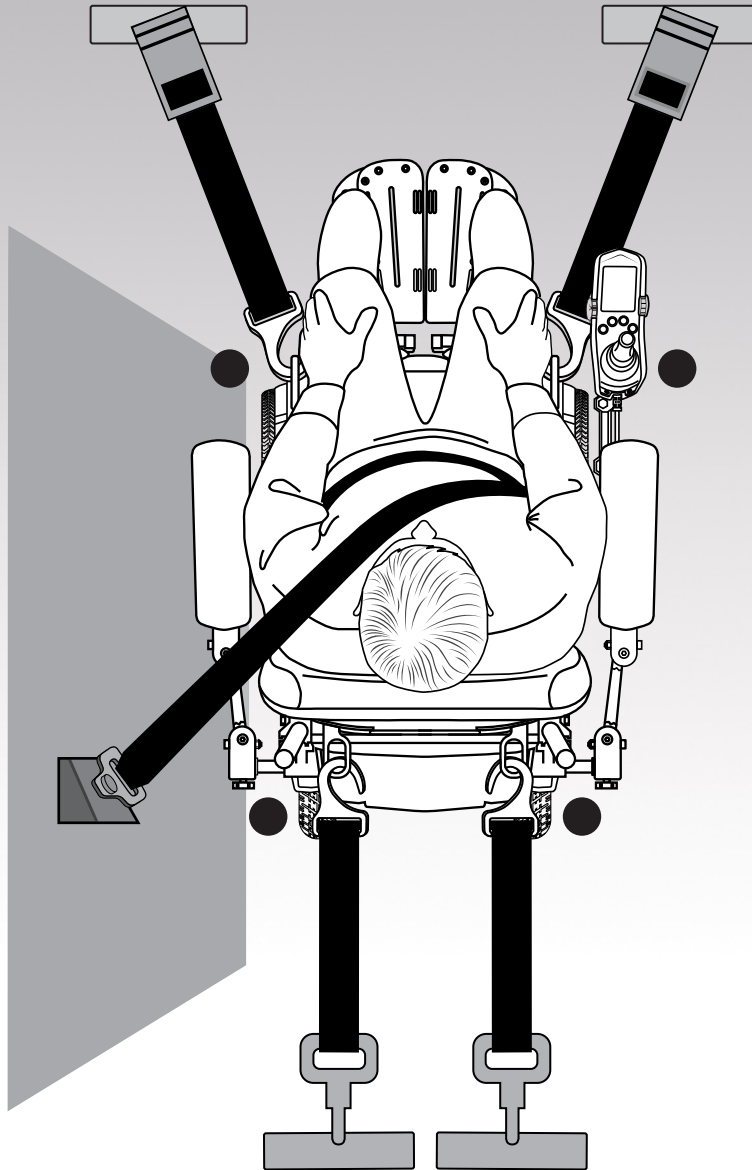

Transit Securement Systems Guide

BASIC OPERATION INSTRUCTIONS FOR OCCUPIED AND UNOCCUPIED TRANSIT







Occupied

Unoccupied

QUANTUM®

PROVIDING GREATER INDEPENDENCE

● =  or   or 

⚠ WARNING!

A Quantum Rehab Provider or a qualified technician must perform the initial setup of this power chair and must perform all of the procedures in this manual.

The symbols below are used throughout this owner's manual and on the power chair to identify warnings and important information. It is very important for you to read them and understand them completely.

⚠ WARNING!

Indicates a potentially hazardous condition/situation. Failure to follow designated procedures can cause either personal injury, component damage, or malfunction. On the product, this icon is represented as a black symbol on a yellow triangle with a black border.

■ MANDATORY!

These actions should be performed as specified. Failure to perform mandatory actions can cause personal injury and/or equipment damage. On the product, this icon is represented as a white symbol on a blue dot with a white border.

⊘ PROHIBITED!

These actions are prohibited. These actions should not be performed at any time or in any circumstances. Performing a prohibited action can cause personal injury and/or equipment damage. On the product, this icon is represented as a black symbol with a red circle and red slash.

Intended Use

The intended use of this Pride Mobility Products device is to provide mobility assistance to persons with mobility impairment who have the capacity to operate a motorized mobility power chair in an indoor/outdoor environment.

Regarding Devices for Prescription Use

Our mobility products and their components are available for sale either as retail ("over-the-counter") or with a prescription. When prescribed, the following statement is applicable.

⚠ WARNING!

CAUTION! Federal law restricts this device to sale by or on the order of a physician or other certified personnel licensed by the law of the State (US only) or region in which this personnel practices to use or order the use of this device.

NOTE: These instructions are compiled from the latest specifications and product information available at the time of publication. We reserve the right to make changes as they become necessary. Any changes to our products may cause slight variations between the illustrations and explanations in this manual and the product you have purchased. The latest/current version of this manual is available on our website.

NOTE: This product is compliant with WEEE, RoHS, and REACH directives and requirements.

NOTE: This product meets IPX4 classification (IEC 60529).

NOTE: This product and its components are not made with natural rubber latex. Consult with the manufacturer regarding any after-market accessories.

Table of Contents

Introduction.....	4
Label Information	5
Definitions	5
User Safety Information	6
Protocol and Procedures.....	6
Securing the Power Chair.....	7
Securing the Power Chair Occupant	9
Transit Securement System	11
Important Points to Remember	12
Appendix: Declarations	13

ADVISORY STATEMENT REGARDING CERTAIN COMPONENTRY INCORPORATED BY THIRD-PARTY MANUFACTURERS INTO FINISHED POWER CHAIRS: When Quantum Rehab power bases, seating systems, or other components are incorporated into a finished power chair manufactured or assembled by any third party, that third party is responsible to assure the safety, functionality, and legal compliance of the finished power chair. Quantum Rehab makes no representation concerning the safety, functionality, or legal compliance of the finished power chair or its componentry manufactured by a third party. While Quantum Rehab makes every effort to assure that our components are distributed responsibly, manufacturers, distributors, and consumers are reminded that finished power chairs must comply with a variety of standards and requirements for governmental safety and functionality.

If it is necessary to physically modify a power chair, including the addition of third-party componentry, to accommodate the medical needs of the power chair occupant, a risk assessment in conformance with ISO 14971, as outlined in ISO_7176, should be performed.

Changes to power chairs that are likely to affect conformance and risk evaluation include but are not limited to: moving the securement-point brackets; lowering the back-support height; shortening the seat length; adding secondary postural supports that are not firmly attached to the power chair; adding components that have sharp edges (i.e., edges with less than 0.08 in. [2 mm] radius); or any change that compromises the structural integrity of the power chair frame.

Introduction

MANDATORY!

The following information pertains to power chairs equipped with a factory-installed Pride Transit Securement System, whether designed to accommodate “Occupied” or “Unoccupied” transportation of your power chair in a motor vehicle, as described in detail below. Read this information in its entirety before use of the Pride Transit Securement System as an Occupied seat in a motor vehicle. If you have any questions about this information or about using the Pride Transit Securement System with your power chair as a seat in a motor vehicle, contact your authorized Pride/Quantum Rehab Provider.

The Occupied Pride Transit Securement System conforms with the standard of ANSI/RESNA WC/Vol. 4, Section 19/ISO 7176-19 for the purpose of enabling power chairs to be secured in certain types of motor vehicles. The Pride Transit Securement System, including manufacturer installed front and rear securement brackets and pelvic belt anchoring brackets, has been crash tested in accordance with ANSI/RESNA WC/Vol. 4, Section 19/ISO 7176-19, Frontal Impact Test, with a 170-lb. (76.3-kg) surrogate occupant, which represents a user weight of 165-300-lb. (75 to 136-kg), or a 225-lb. (102.0-kg) surrogate occupant, which represents a user weight of >300-lb. (>136-kg).

Notwithstanding this standard and testing conformance, many government transportation agencies, at the time of this publication, have not approved any securement system for the transport of an occupied power chair in a motor vehicle, while the power chair is occupied by a person. Therefore, it is the position of Pride Mobility Products and Quantum Rehab that the Occupied version of the Pride Transit Securement System should only be used to secure an occupied power chair being transported in a motor vehicle at the user’s discretion and in accordance with ANSI/RESNA WC/Vol. 4, Section 19/ISO 7176-19 standards, which are intended to increase safety, but do not suggest that compliance with the standards will necessarily prevent serious injury or death of a secured power chair occupant during motor vehicle transport.

In accordance with the ANSI/RESNA WC/Vol. 4, Section 19/ISO 7176-19 standards, Pride and Quantum recommend that the power chair user transfer into the vehicle seat and use the vehicle-installed belt restraint system if and whenever feasible.

The Pride Transit Securement System is only available when factory-installed on new power chairs, and cannot be retrofitted on existing power chairs or serviced in the field.

PROHIBITED!

Do not modify your power chair in any way not authorized by Quantum Rehab. Do not make alterations or substitutions to power chair structural parts or frame components without consulting Quantum. Do not add any accessories to a power chair equipped with a factory-installed Pride Transit Securement System without first consulting Pride/Quantum Rehab.

Label Information



Read and follow the information in the owner's manual and all supplemental information provided with the power chair before initial operation.



Indicates that the power chair or power chair component (base or seating system) contains a Transit Securement System that conforms to ANSI/RESNA WC/Vol. 4, Section 19/ISO 7176-19 for transport of an Occupied power chair in a motor vehicle.



Indicates power chair with similar label is not rated for occupied transit.



or Indicates **OCCUPIED** power chair securement points.



or Indicates **UNOCCUPIED** power chair securement points.



WARNING! Indicates a potentially hazardous condition/situation. Failure to follow designated procedures can cause either personal injury, component damage, or malfunction. On the product, this icon is represented as a black symbol on a yellow triangle with a black border.



MANDATORY! These actions should be performed as specified. Failure to perform mandatory actions can cause personal injury and/or equipment damage. On the product, this icon is represented as a white symbol on a blue dot with a white border.



PROHIBITED! These actions are prohibited. These actions should not be performed at any time or in any circumstances. Performing a prohibited action can cause personal injury and/or equipment damage. On the product, this icon is represented as a black symbol with a red circle and red slash.



IMPORTANT! Indicates important information to remember when using this product.

Definitions

- **ANSI/RESNA:** American National Standards Institute/Rehabilitation Engineering and Assistive Technology Society of North America (<http://www.ansi.org>)
- **ISO:** International Standards Organization (<http://www.iso.org>)
- **Securement Points:** Specific structural points on the power chair base or seat frame that are designed for attachment of a WTORS. These securement points are indicated by anchor symbols.
- **Transit Securement System:** Equipment installed on the power chair which allows the power chair to be anchored in a motor vehicle. The equipment consists of tie-down anchor points and may include a pelvic belt. The equipment differs depending on whether the Transit Securement System is intended to accommodate Occupied vs. Unoccupied transport of the power chair in a motor vehicle.
- **Wheelchair Tie-down and Occupant Restraint System (WTORS):** Equipment installed in a motor vehicle which allows a power chair and/or a power chair-seated occupant to be anchored in the motor vehicle for limiting occupant movement in a motor vehicle crash. The equipment consists of a system or device for securing the power chair and a belt-type restraint system.

User Safety Information

MANDATORY!

Always secure the power chair and occupant in a forward-facing position in the vehicle.

The power chair should be used as indicated in the manufacturer's instructions. If you have any questions about the proper use of your power chair, contact your Quantum Provider.

Only belt restraints that comply with the provisions of ANSI/RESNA WC/Vol. 4, Section 19/ISO 7176-19 and that have been dynamically tested in accordance with this standard should be installed on the power chair for use as a restraint in a motor vehicle.

WARNING!

If the total power chair mass is greater than 275 lbs. (125 kg), then transport in a motor vehicle with a gross vehicle weight greater than 8,800 lbs. (4,000 kg) is recommended if the option exists.

Protocols and Procedures

Pride and Quantum recommend that, whenever traveling in a motor vehicle, the power chair user should transfer into the vehicle seat and use the vehicle-installed restraint system if and whenever feasible. The power chair should then be stored and secured in the vehicle.

For users choosing to remain in their power chair during motor vehicle transport, in addition to the Pride Transit Securement System for Occupied transport, the vehicle must be equipped with a Wheelchair Tie-down and Occupant Restraint System (WTORS) that has been installed in accordance with the tie-down manufacturer's instructions, and is compliant with ANSI/RESNA WC/Vol. 4, Section 18/ISO 10542 standards. It is essential to use a complete WTORS to secure the power chair to the vehicle. In addition to compliance with the above standards, the WTORS must be equipped with both pelvic and upper-torso belts to protect the power chair occupant and minimize the likelihood of injury caused by contact with the vehicle during a crash or sudden braking.

WARNING!

Only power chairs marked with this symbol are rated for occupied transport.

WARNING!

If the total power chair mass is greater than 275 lbs. (125 kg), then it is recommended that two additional ANSI/RESNA WC/Vol. 4, Section 18/ISO 10542 compliant rear securement straps be used to anchor the power chair during motor vehicle transport.

Securing the Power Chair (Unoccupied)

NOTE: In addition to following the general guidelines below, be sure to follow all warnings, instructions, and recommendations provided by the WTORS manufacturer.

- Always secure the power chair in a forward-facing position in the vehicle.
- Attach the four, six, or eight tie-down straps only to designated, labeled transit securement points indicated by anchor symbols on the power chair. **See figures 1 through 5.** Tighten the straps to sufficiently remove all slack.
- Never attach tie-downs to adjustable, moving, or removable parts of the power chair such as armrests, front riggings, and wheels.
- Position the anchor points for the rear tie-down straps directly behind the rear securement points on the power chair. The front tie-down straps should anchor to floor points that are spaced wider than the power chair to provide increased lateral stability. **See figure 1.**

WARNING!

Ensure power chairs equipped with a Pride Transit Securement System are properly secured to the motor vehicle during transport. Power chairs that are not properly secured can become a hazard to the user and to other vehicle passengers in the event of a crash, sudden stopping, or swerving, as the power chair could tip or slide out of place.

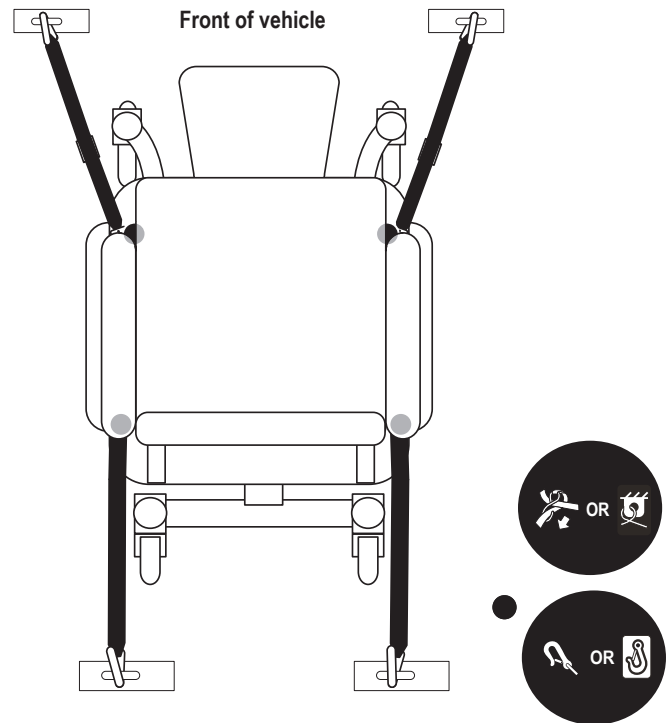

Figure 1. Securing the Power Chair

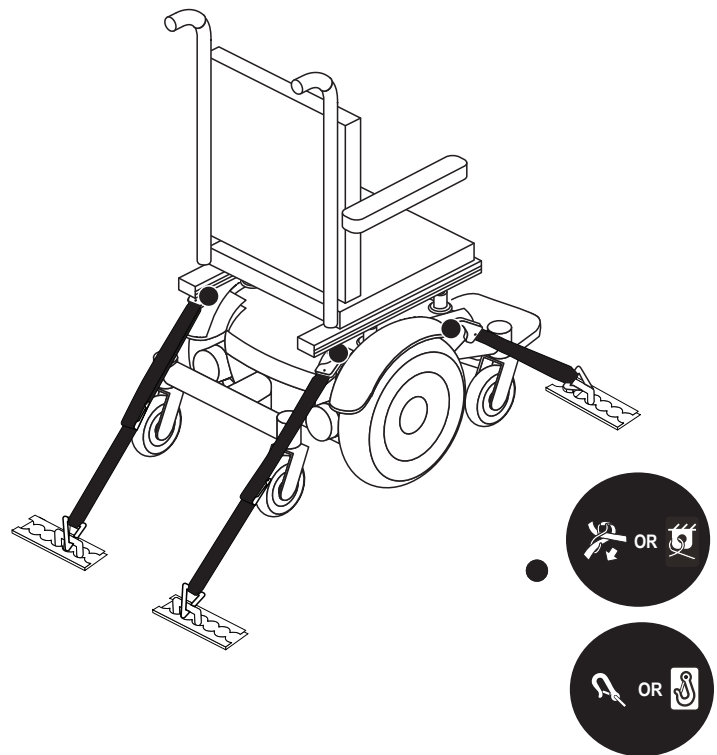

Figure 2. Tie-down System

Unoccupied and Occupied Securement Points

■ The Pride Transit Securement System includes WTORS belt restraint anchor points in conformance with ANSI/RESNA WC/Vol. 4, Section 19/ISO 7176-19. See figures 3, 4, and 5.

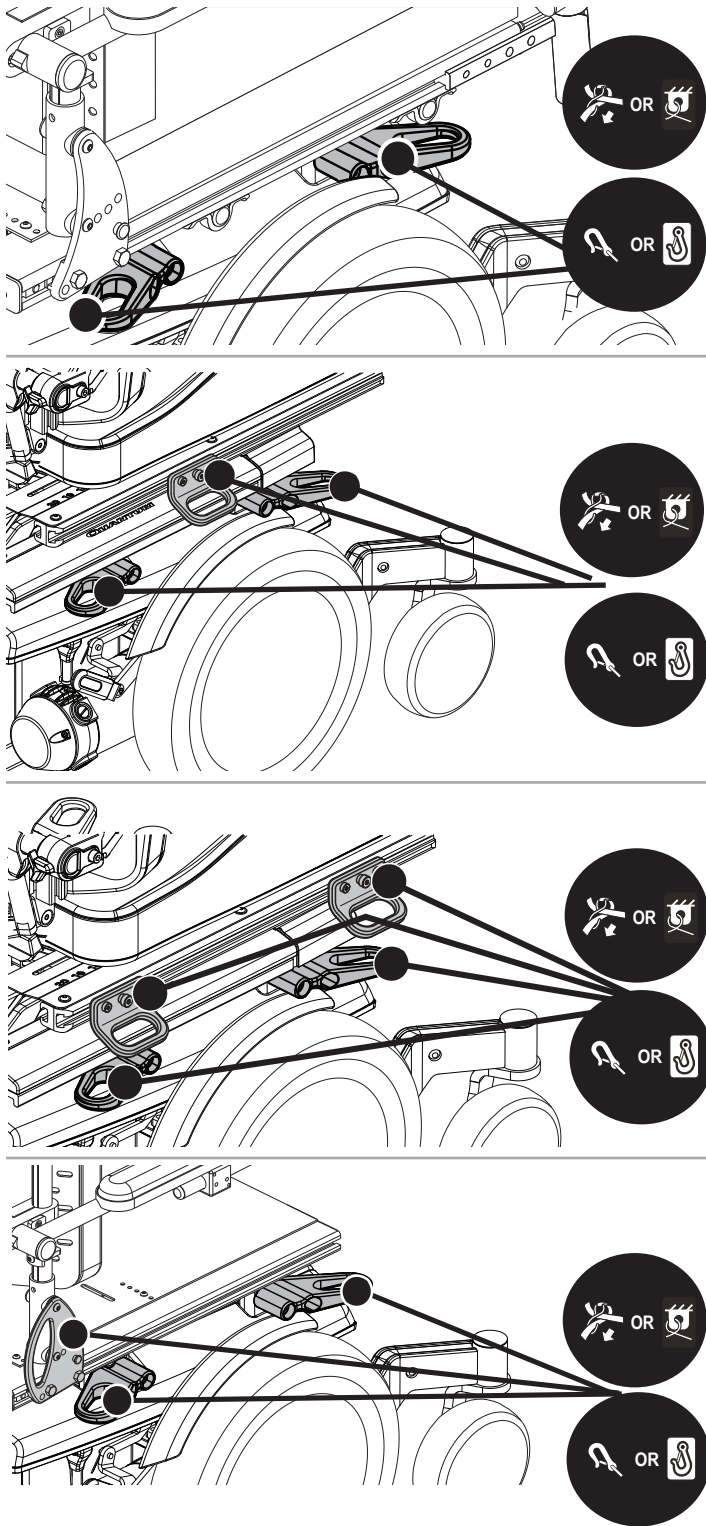

Figure 3. WTORS Belt Restraint Securement Points on Mid-wheel Drive Power Chairs (Right Sides Shown)

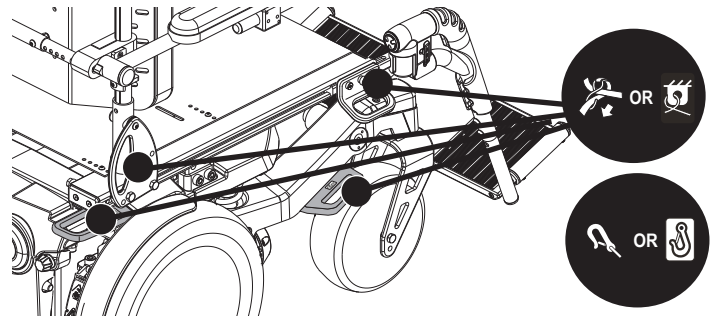

Figure 4. WTORS Belt Restraint 8-Point Securement on Rear-wheel Drive Power Chairs (Right Side Shown)

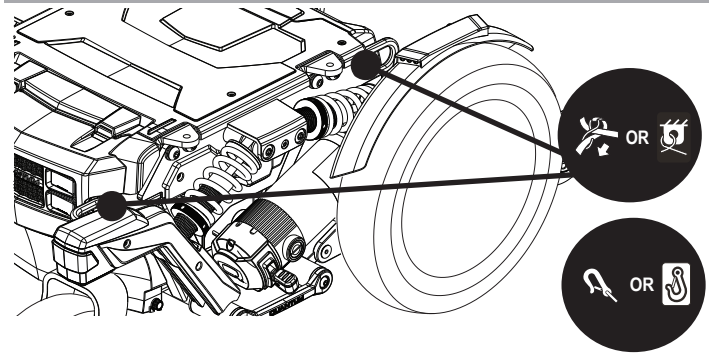

Figure 5. WTORS Belt Restraint 4-Point Securement on Front-wheel Drive Power Chairs (Right Side Shown)

Securing the Power Chair Occupant (Applies to Transit Securement Systems Designed to Accommodate for Occupied Transport Use Only) Once the power chair has been properly secured, it is essential that the power chair occupant be protected for transport.

⚠ WARNING!

The power chair occupant must be secured with dynamically crash-tested and approved pelvic and upper-torso belts or with a five-point child restraint harness as part of WTORS.

- Always secure the power chair occupant in a forward-facing position in the vehicle with a crash-tested pelvic belt that is anchored to the seat frame; complete the restraint system by attaching the lower end of the WTORS upper-torso belt to the pelvic belt by referring to the WTORS manufacturer's instruction.
- Place the pelvic belt across the front of the pelvis near the upper thighs, not high over the abdomen.

⚠ WARNING!

The pelvic belt should be angled between 45 degrees and 75 degrees to the horizontal when viewed from the side. However, if the user cannot achieve this standard, an optional zone of 30 degrees to 45 degrees can be utilized safely.

- The frontal clear zone (FCZ) is measured from the forwardmost point on the occupant's head and should measure at least 26 in. (65 cm) if both a pelvic and upper-torso belt are used. See figure 7.

NOTE: The recommended frontal clear zone may not be achievable for power chair-seated vehicle operators.

- The rear clear zone (RCZ) is measured from the rearmost point on the occupant's head and should measure at least 16 in. (40 cm). See figure 7.
- The seated head height (HHT) ranges from about 47 in. (120 cm) for a small adult female to about 61 in. (155 cm) for a tall adult male. See figure 7.

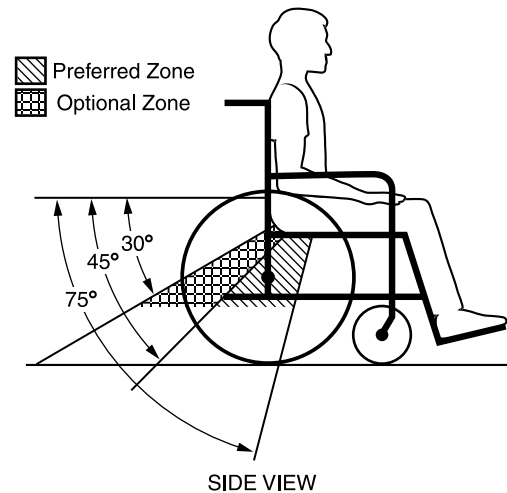
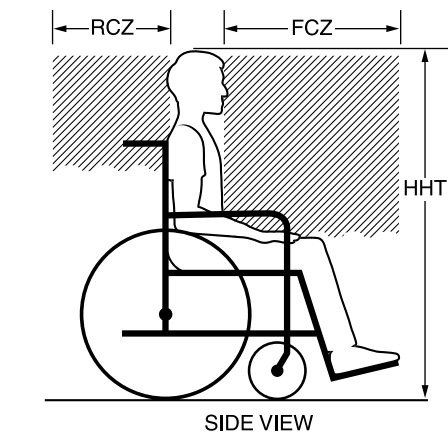

Figure 6. Recommended Pelvic Belt Placement Angles



FCZ = FRONTAL CLEAR ZONE
RCZ = REAR CLEAR ZONE
HHT = SEATED HEAD HEIGHT

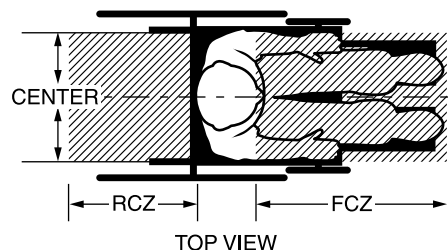

Figure 7. Recommended Clear Zones for Power Chair-seated Occupants

⚠ WARNING!

Always allow for proper clear zones when securing an occupied power chair in a motor vehicle.

Allow as much clearance as possible around the power chair occupant to reduce the possibility of contact with vehicle components and other passengers in the event of a crash.

Ensure all vehicle components that are in close proximity to the power chair occupant are removed or covered with dense padding.

NOTE: For a WC-19 crash-test-approved belt, please contact Qstraint at www.qstraint.com or 1-800-987-9987.

- Some power chair components, like armrests and wheels, can interfere with proper belt fit. It may be necessary to insert the belt between the armrest and the seatback or through openings between the backrest and seat in order to avoid placing the pelvic belt over the armrest. **See figure 8.**
- Place the upper-torso belt across the middle of the shoulder and the center of the chest, and connect to the pelvic belt near the hip of the power chair occupant. **See figure 9.**

⚠ WARNING!

The upper-torso belt webbing should not be worn twisted in a manner that reduces the area of contact of the belt with the occupant.

- The use of postural pelvic belts attached to the power base or seat frame is encouraged during travel, but these belts should be positioned so that they do not interfere with the proper positioning of crashworthy belt restraints and should not be relied on for occupant protection in crash situation unless the postural belt complies with the requirements of RESNA WC-4 Sections 18/19.
- The upper-torso belt anchor point should be anchored above and behind the top of the power chair occupant's shoulder to ensure that the occupant is properly restrained during transport. Both the pelvic and upper-torso belt restraints should be adjusted as snugly as possible consistent with user comfort.

Pelvic restraints should make full contact across the front of the body near the junction of the thigh and pelvis.

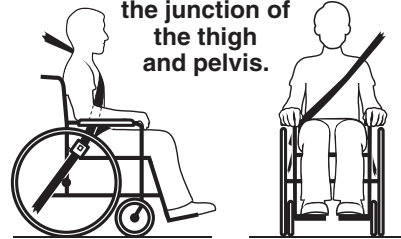

Belt restraints must not be held away from the body by power chair components such as armrests or wheels.



Figure 8. Proper Pelvic Belt Placement

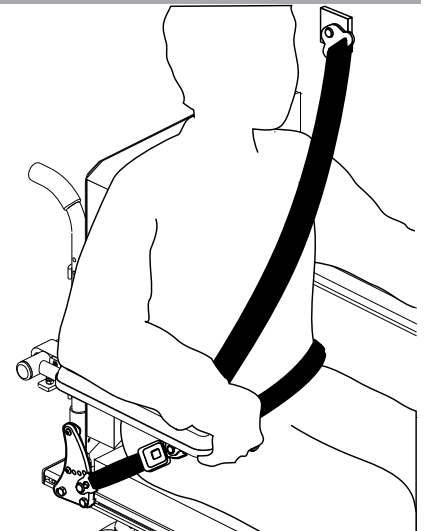

Figure 9. Proper Upper-torso Belt Placement

⚠ WARNING!

The buckle of belt restraint systems should not be located near power chair components that may come in contact with the buckle release button in the event of a vehicle accident or collision.

- If your power chair is equipped with a crash-tested pelvic belt that is anchored to the seat frame, complete the restraint system by attaching the lower end of the WTORS upper-torso belt to the pelvic belt by referring to the WTORS manufacturer's instruction. Crash-tested power chair-anchored pelvic belts will be labeled to indicate compliance to the ANSI/RESNA WC/Vol 4, Section 19/ISO 7176-19 standards. See figure 10.

■ MANDATORY!

A vehicle-anchored belt restraint system conforming to ANSI/RESNA WC/Vol 4, Section 18/ISO 10542 must be used if the power chair occupant chooses not to utilize a manufacturer-installed power chair-anchored belt restraint system. Contact the belt restraint system manufacturer to confirm certification prior to use.

⚠ WARNING!

Although postural supports and belts may be used in a moving vehicle in addition to the occupant belt restraint system, they should not be relied upon to replace occupant restraints that have been designed and tested for this purpose and should not interfere with proper belt restraint placement.

Transit Securement System

The following components of the transit securement system must be compliant to ANSI/RESNA WC/Vol. 4, Section 18/ISO 10542 standards (formerly SAE J2249) and must be installed according to the manufacturer's instructions.

- Wheelchair Tie-down and Occupant Restraint System (WTORS)
- 4-point, 6 point, or 8-point power chair tie-down system with an integrated 3-point occupant restraint
- Tie-down end fittings
- WTORS securement points
- Occupant restraint securement points

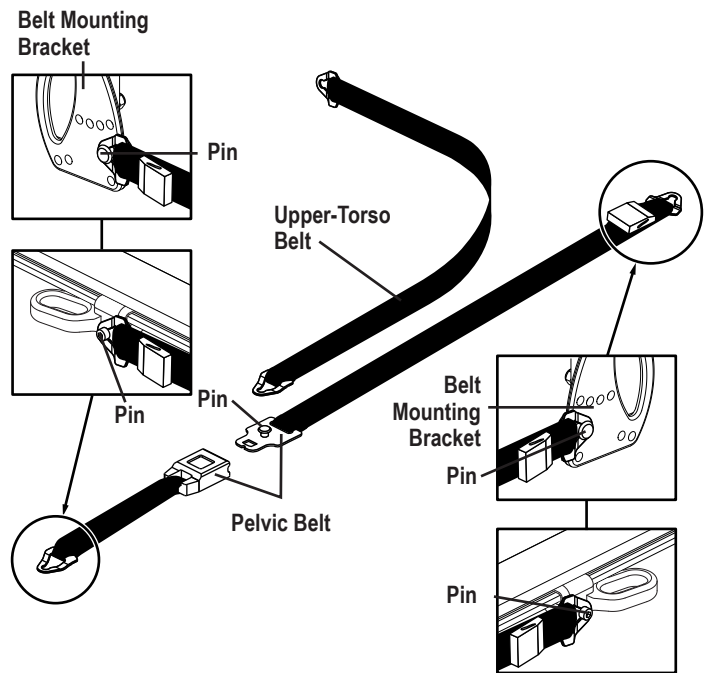

Figure 10. Power Chair-anchored Belt Restraint

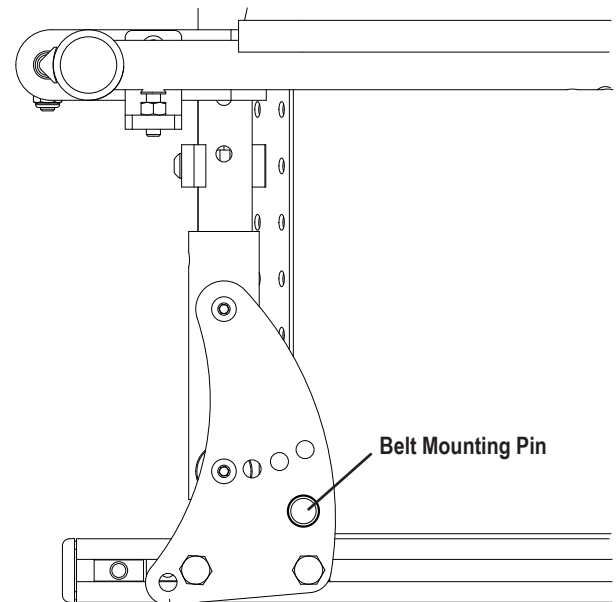

Figure 11. Power Chair Belt Restraint Anchor

NOTE: To obtain a copy of ANSI/RESNA WC/Vol. 4, Sections 18 and/or 19 visit <http://www.ansi.org>.

NOTE: To obtain a copy of ISO 7176-19 or ISO 10542 visit <http://www.iso.org>.

Important Points to Remember (Unoccupied and Occupied)

MANDATORY!

Read and follow all manufacturer's instructions, including the product owner's manual.

MANDATORY!

Any WTORS or power chair involved in a vehicle crash should be replaced.

WARNING!

The power chair seat should never be raised or elevated while the power chair is secured in a vehicle for occupied or unoccupied transit. Failure to heed may result in personal injury and/or property damage.

The power chair seatback should be positioned at an angle of no more than 30 degrees to the vertical. If a greater recline angle is required, the upper-torso belt anchor point should be moved rearward along the vehicle's sidewall to ensure that the belt maintains contact with the power chair occupant's shoulder and chest.

Visually inspect all WTORS equipment according to WTORS manufacturer's instructions on a regular basis, and have worn or broken components replaced immediately. Ensure anchorage track is free of dirt and debris.

Ensure that any removable components are securely attached to the powerchair and remove and stow all removable accessories elsewhere in the vehicle to reduce the chance of power chair occupant injury.

Contents of non-removable accessories should also be stowed.

WARNING!

Consider using foam trays in place of rigid trays during vehicle transport. If that is not possible, place dense foam padding between the power chair occupant and the tray, and make sure that the tray is securely attached to the power chair so that it will not break loose and cause injury to other occupants in a crash.

Ensure the power chair occupant is properly positioned to protect the neck during rear impact.

Secure all removable accessories, including clothing guards, medical, and other equipment to the power chair or vehicle to prevent injury during a crash.

If head and neck support is required during travel, use a soft, light neck collar as they are less likely to cause neck injury in a crash. Do not attach the soft collar to the power chair or seating system.

Appendix: Declarations

Pride Occupied Transit Securement System Declarations



MANDATORY! A belt restraint system with both pelvic and upper-torso belts must be used to protect the power chair occupant and minimize the likelihood of injury caused by contact with the vehicle during a crash or sudden braking.



The occupied power chairs noted in the table were dynamically tested in a forward-facing position, with a surrogate 3-point belt and a power chair-anchored lap belt, and conform with ANSI/RESNA WC/Vol.4, Section 19/ISO 7176-19.

NOTE: For additional model specific information, such as overall unit size, weight, turning radius, etc., refer to the product specification sheet included with your power chair owner's manual.

NOTE: Other configurations are considered WC-19 and/or ISO 7176-19 compliant. Contact your Quantum Rehab Provider for more information.

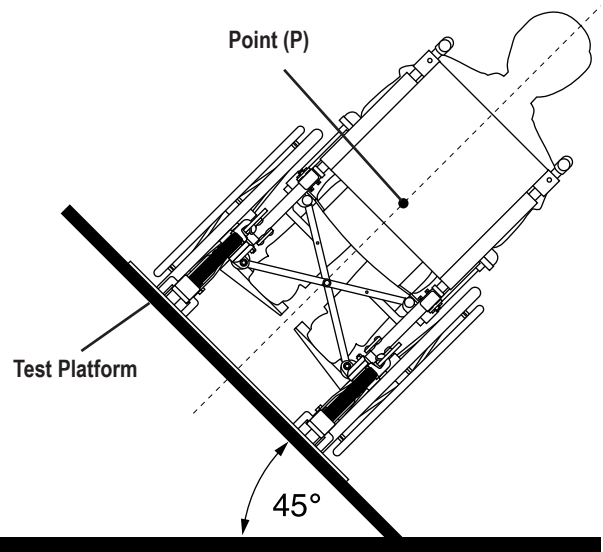

NOTE: Rear view of the power chair and human surrogate secured on test platform and tilted to 45°.

Figure 12. Lateral Stability Displacement Illustration

			Ratings				
			Occupant Restraints		Compliance with front-impact requirements		
Power Chair Name and Model	Mass of the Unoccupied Power chair under Test	Number and location of Securement	Ease of Positioning	Degree achieved	5.3.2 of ANSI/RESNA WC-4, Section 19 (WC-19)	5.2 of ISO 7176-19 (ISO)	Lateral Stability
Q6 Edge 3 Stretto with: –Static Contoured Seat –iLevel® Contoured Seat (Captain’s Seat)	Up to 380 lbs. (172.7 kg)	Static: Surrogate 4-pt., strap-type tie-down iLevel: Surrogate 6-pt., strap-type tie-down	Excellent	Good	Meets	Meets	Acceptable
Q6 Edge 3 Stretto with: –TRU-Balance® 3	Up to 407 lbs. (185 kg)	Surrogate 6-pt., strap-type tie-down	Excellent	Good	Meets	Meets	Acceptable
Q6 Edge 3 Stretto with: –TB-Flex Static Seat	Up to 293 lbs. (132.9 kg)	Surrogate 6-pt., strap-type tie-down	Excellent	Good	Meets	Meets	Acceptable
Q6 Edge 3 Stretto with: –TB-Flex Tilt Seat	Up to 271 lbs. (122.9 kg)	Surrogate 6-pt., strap-type tie-down	Excellent	Good	Meets	Meets	Acceptable
Q6 Edge 2.0/Q6 Edge 3 with: –TRU-Balance 3	Up to 450 lbs. (204.5 kg)	Surrogate 6-pt., strap-type tie-down	Excellent	Excellent	Meets	Meets	N/A
Q6 Edge 2.0/Q6 Edge 3 with: –TB-Flex Static Seat	Up to 293 lbs. (132.9 kg)	Surrogate 6-pt., strap-type tie-down	Excellent	Excellent	Meets	Meets	N/A
Q6 Edge 2.0/Q6 Edge 3 with: –Static Contoured Seat –iLevel Contoured Seat (Captain’s Seat)	Up to 380 lbs. (172.7 kg)	Static: Surrogate 4-pt., strap-type tie-down iLevel: Surrogate 6-pt., strap-type tie-down	N/A	N/A	Meets	Meets	N/A
Q6 Edge HD with: –Synergy Seat	Up to 365 lbs. (165.6 kg)	Surrogate 4-pt., strap-type tie-down	Good	Good	Meets	Meets	N/A
Quantum 4Front with: –TRU-Balance 3	Up to 460 lbs. (209.1 kg)	Surrogate 6-pt., strap-type tie-down	Excellent	Excellent	Meets	Meets	N/A
J4 with: –Q4 Tilt Seat –Captain’s Seat	Up to 360 lbs. (163.3 kg)	Surrogate 4-pt., strap-type tie-down	Excellent	Excellent	Meets	Meets	N/A
J4 HD with: –Q4 Tilt Seat	Up to 360 lbs. (163.3 kg)	Surrogate 6-pt., strap-type tie-down	Excellent	Excellent	Meets	Meets	N/A
J6 VA (available to VA only) with: –Captain’s Seat	Up to 218 lbs. (99.1 kg)	Surrogate 4-pt., strap-type tie-down	N/A	N/A	Meets	N/A	N/A
Q6 Edge Z with: –TRU-Balance 3	Up to 471 lbs. (214.1 kg)	Surrogate 6-pt., strap-type tie-down	Excellent	Excellent	Meets	Meets	Good
4Front 2 HD with –TRU-Balance 3	Up to 446lbs. (202.7kg)	Surrogate 6-pt., strap-type tie-down	Excellent	Good	Meets	Meets	Acceptable



Transit Securement Systems Guide

USA

401 York Avenue
Duryea, PA 18642
www.quantumrehab.com

Canada

5096 South Service Road
Beamsville, Ontario L3J 1V4
www.quantumrehab.ca

Australia

20-24 Apollo Drive
Hallam, Victoria 3803
www.quantumrehab.com.au

New Zealand

3-5/208 Swanson Road
Henderson, Auckland 0610
www.pridemobility.co.nz

UK

(Authorised UK Representative)
32 Wedgwood Road
Bicester, Oxfordshire OX26 4UL
www.quantumrehab.co.uk

The Netherlands

(Authorised EU Representative)
De Zwaan 3
1601 MS Enkhuizen
www.quantumrehab.eu
www.quantumrehab.nl

Switzerland

(Authorised CH Representative)
SODIMED SA
Chemin Praz Devant 12
1032 Romanel-sur-Lausanne

Italy

Via del Progresso, ang. Via del Lavoro
Loc. Prato della Corte
00065 Fiano Romano (RM)
www.quantumrehab-italia.it

France

26 Rue Monseigneur Ancel
69800 Saint-Priest
www.quantumrehab.fr

Spain

Calle Las Minas Número 67
Polígono Industrial Urtinsa II, de Alcorcón
28923 Madrid
www.quantumrehab.es

Germany

Hövelrieger Str. 28
33161 Hövelhof
www.quantumrehab.de

China

Room 508, Building #4
TianNa Business Zone
No. 500 Jianyun Road
Pudong New Area
Shanghai 201318
www.pridechina.cn



I N F M A N U 3 6 5 8