

# QUANTUM

**SERIES**



**OWNER'S MANUAL**

*Including Models: Quantum 1121*

**Pride**

Mobility Products Australia Pty. Ltd.  
[www.pridemobility.com](http://www.pridemobility.com)

21 Healey Road Dandenong, 3175 Victoria, Australia

# SAFETY GUIDELINES



**WARNING! A Quantum Rehab Provider or a qualified technician must perform the initial setup of this power chair and must perform all of the procedures in this manual.**

The symbols below are used throughout this owner's manual and on the power chair to identify warnings and important information. It is very important for you to read them and understand them completely.



**WARNING! Indicates a potentially hazardous condition/situation. Failure to follow designated procedures can cause either personal injury, component damage, or malfunction. On the product, this icon is represented as a black symbol on a yellow triangle with a black border.**



**MANDATORY! These actions should be performed as specified. Failure to perform mandatory actions can cause personal injury and/or equipment damage. On the product, this icon is represented as a white symbol on a blue dot with a white border.**



**PROHIBITED! These actions are prohibited. These actions should not be performed at any time or in any circumstances. Performing a prohibited action can cause personal injury and/or equipment damage. On the product, this icon is represented as a black symbol with a red circle and red slash.**

## Quick Reference Information

Quantum Rehab Provider: \_\_\_\_\_

Address: \_\_\_\_\_

Phone Number: \_\_\_\_\_

Purchase Date: \_\_\_\_\_

***NOTE: This owner's manual is compiled from the latest specifications and product information available at the time of publication. We reserve the right to make changes as they become necessary. Any changes to our products may cause slight variations between the illustrations and explanations in this manual and the product you have purchased. The latest/current version of this manual is available on our website.***

This product is manufactured by:  
Pride Mobility Products Corp.  
182 Susquehanna Avenue  
Exeter, PA 18643  
USA

Copyright © 2009  
Pride Mobility Products Australia Pty. Ltd.  
INFMANU3343/Rev B/February 2009

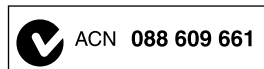

# CONTENTS

<b>I. INTRODUCTION</b> .....	4
<b>II. SAFETY</b> .....	5
<b>III. YOUR POWER CHAIR</b> .....	13
<b>IV. ASSEMBLY</b> .....	17
<b>V. COMFORT ADJUSTMENTS</b> .....	19
<b>VI. BATTERIES AND CHARGING</b> .....	26
<b>VII. CARE AND MAINTENANCE</b> .....	30
<b>VIII.WARRANTY</b> .....	35
<b>APPENDIX I - SPECIFICATIONS</b> .....	36

# I. INTRODUCTION

## **SAFETY**

WELCOME to Quantum Rehab, a division of Pride Mobility Products Australia Pty. Ltd. (Pride). The power chair you have purchased combines state-of-the-art components with **safety**, comfort, and styling in mind. We are confident that these design features will provide you with the conveniences you expect during your daily activities. Once you understand how to **safely** operate and care for your power chair, it should give you years of trouble free operation and service.

**Read and follow** all instruction, warnings, and notes in this manual before attempting to operate your power chair for the first time. You must also read all instructions, warnings, and notes contained in any supplemental instructional booklets for the controller, front riggings, and/or seating system that accompanied your power chair before initial operation. Your **safety** depends upon you, as well as your provider, carer, or healthcare professional in using good judgement.

If there is any information in this manual which you do not understand, or if you require additional assistance for setup or operation, please contact your Quantum Rehab Provider. **Failure to follow the instructions in this manual and those located on your power chair can lead to personal injury and/or damage to the power chair, including voiding the warranty.**

## **SHIPPING AND DELIVERY**

Before using your power chair, make sure your delivery is complete as some components may be individually packaged. If you do not receive a complete delivery, please contact your Quantum Rehab Provider immediately. Where damage has occurred during transport, either to the packaging or content, please contact the delivery company responsible.

## **PURCHASER'S AGREEMENT**

By accepting delivery of this product, you promise that you will not change, alter, or modify this product or remove or render inoperable or unsafe any guards, shields, or other safety features of this product; fail, refuse, or neglect to install any retrofit kits from time to time provided by Pride to enhance or preserve the safe use of this product.

## **INFORMATION EXCHANGE**

We want to hear your questions, comments, and suggestions about this manual. We would also like to hear about the safety and reliability of your new power chair, and about the service you received from your Quantum Rehab Provider.

Please notify us of any change of address, so we can keep you apprised of important information about safety, new products, and new options that can increase your ability to use and enjoy your power chair. Please feel free to contact us at the address below:

Pride Mobility Products Australia Pty. Ltd.  
21 Healey Road  
Dandenong, 3175  
Victoria, Australia

***NOTE: If you ever lose or misplace your product registration card or your copy of this manual, contact us and we will be glad to send you a new one immediately.***

# II. SAFETY

## SAFETY



**MANDATORY! Do not operate your new power chair for the first time without completely reading and understanding this owner's manual.**

Your power chair is a state-of-the-art life-enhancement device designed to increase mobility. Pride provides an extensive variety of products to best fit the individual needs of the power chair user. Please be aware that the final selection and purchasing decision regarding the type of power chair to be used is the responsibility of the power chair user, who is capable of making such a decision, and his/her healthcare professional (i.e., medical doctor, physical therapist, etc.).

The contents of this manual are based on the expectation that a mobility device expert has properly fitted the power chair to the user and has assisted the prescribing healthcare professional and/or the Quantum Rehab Provider in the instruction process for the use of the product.

There are certain situations, including some medical conditions, where the power chair user will need to practice operating the power chair in the presence of a trained attendant. A trained attendant can be defined as a family member or care professional specially trained in assisting a power chair user in various daily living activities.

As you begin using your power chair during daily activities, you will probably encounter situations in which you will need some practice. Simply take your time and you will soon be in full and confident control as you maneuver through doorways, on and off of lifts, up and down ramps, and over moderate terrain.

Below are some precautions, tips, and other safety considerations that will help you become accustomed to operating your power chair safely.

### Modifications

Pride has designed and engineered your power chair to provide maximum mobility and utility. A wide range of accessories is available from your Quantum Rehab Provider to further customise your power chair to better suit your needs and/or preferences. However, under no circumstances should you modify, add, remove, or disable any feature, part, or function of your power chair.



**WARNING! Do not modify your power chair in any way not authorised by Pride. Do not use accessories if they have not been tested or approved for Pride products.**

### Pre-Ride Safety Check

Get to know the feel of your power chair and its capabilities. Pride recommends that you perform a safety check before each use to make sure your power chair operates smoothly and safely. See VIII. "Care and Maintenance."

### Perform the following inspections prior to using your power chair:

- Check for proper tyre inflation. Maintain but do not exceed the psi/bar/kPa air pressure rating in each tyre if equipped with pneumatic tyres.
- Check all electrical connections. Make sure they are tight and not corroded.
- Check all controller connections to the electronics tray. Make sure they are secured properly.
- Check the brakes. See VIII. "Care and Maintenance."
- Check battery charge. See VI. "Batteries and Charging."

**NOTE: If you discover a problem, contact your Quantum Rehab Provider for assistance.**

## II. SAFETY

### Weight Limitations

Your power chair is rated for a maximum weight capacity. Please refer to the specifications table for this limit.



**MANDATORY!** Stay within the specified weight capacity of your power chair. Exceeding the weight capacity voids your warranty. Pride will not be held responsible for injuries and/or property damage resulting from failure to observe weight limitations.



**WARNING!** Do not carry passengers on your power chair. Carrying passengers on your power chair may affect the center of gravity, resulting in a tip or a fall.

### Tyre Inflation

If your power chair is equipped with pneumatic tyres, you should check or have the air pressure checked regularly. Proper inflation pressures will prolong the life of your tyres and help ensure the smooth operation of your power chair.



**WARNING!** It is important that the psi/bar/kPa air pressure rating indicated on the tyre be maintained in pneumatic tyres at all times. Do not underinflate or overinflate your tyres. Low pressure may result in loss of control, and overinflated tyres may burst. Failure to maintain the psi/bar/kPa air pressure rating indicated on the tyres at all times may result in tyre and/or wheel failure.

**WARNING!** Inflate your power chair drive tyres from a regulated air source with an available pressure gauge. Inflating your tyres from an unregulated air source could overinflate them, resulting in a burst tyre.

*NOTE: If the tyres on your power chair lists the psi rating only, use the following conversion formulas to find the bar or kPa rating:  $bar = psi \times 0.06895$ ;  $kPa = psi \times 6.89476$ .*

### Incline Information

More and more buildings have ramps with specified degrees of inclination, designed for easy and safe access. Some ramps may have turning switchbacks (180-degree turns) that require you to have good cornering skills on your power chair.

- Proceed with extreme caution as you approach the downgrade of a ramp or other incline.
- Take wide swings with your power chair's front wheels around any tight corners. If you do that, the power chair's rear wheels will follow a wide arc, not cut the corner short, and not bump into or get hung up on any railing corners.
- When driving down a ramp, keep the power chair's speed adjustment set to the slowest speed setting to ensure a safely controlled descent.
- Avoid sudden stops and starts.

When climbing an incline, try to keep your power chair moving. If you must stop, start up again slowly and then accelerate cautiously. When driving down an incline, set your power chair to the slowest setting and drive in the forward direction only. If your power chair starts to move down the incline faster than you anticipated or desired, allow it to come to a complete stop by releasing the joystick, then push the joystick forward slightly to ensure a safely controlled descent.

**WARNING!** When climbing an incline, do not zigzag or drive at an angle up the face of the incline. Drive your power chair straight up the incline. This greatly reduces the possibility of a tip or a fall. Always exercise extreme caution when negotiating an incline.



**WARNING!** You should not travel up or down a potentially hazardous incline (i.e., areas covered with snow, ice, cut grass, or wet leaves).

**WARNING!** When on any sort of an incline or decline, never place the power chair in freewheel mode while seated on it or standing next to it.

**WARNING!** Never travel down an incline backward. Doing so may cause the power chair to tip. Always exercise extreme caution when negotiating an incline.

## II. SAFETY

**WARNING!** If your power chair is equipped with a reclining seatback, do not attempt to negotiate inclines with the seat in a reclined position. Do not attempt to negotiate obstacles with the seat in a reclined position unless an attendant is present to help stabilise the chair. Failure to heed may result in the power chair tipping over.



**WARNING!** Even though your power chair is capable of climbing slopes greater than those illustrated in figure 1, do not, under any circumstances, exceed the incline guidelines or any other specifications presented in this manual. Doing so could cause instability in your power chair.

Pride recommends that the maximum slope of an incline you attempt to safely ascend or descend on your power chair does not exceed 8.7% (5°). See figure 1.



**WARNING!** Any attempt to climb or descend a slope steeper than 8.7 % (5°) may put your power chair in an unstable position and cause it to tip.

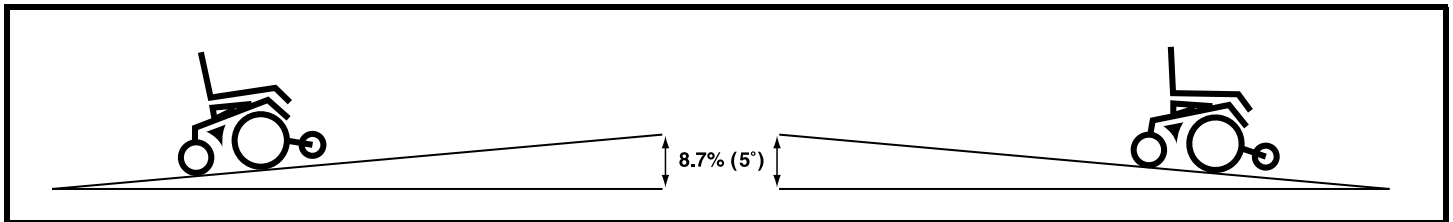

Figure 1. Maximum Safe Angle (Ascending and Descending)

### Freewheel Mode

Your power chair is equipped with two manual freewheel levers to allow for manual maneuverability by a trained attendant. For more information about how to place your power chair into and out of freewheel mode, see III. “Your Power Chair.”

**WARNING!** Do not use your power chair in freewheel mode without an attendant present.



**WARNING!** Do not attempt to personally place your power chair in freewheel mode while seated on it. Ask an attendant for assistance if necessary.

**WARNING!** Do not place your power chair in freewheel mode while on an incline. This could cause the chair to roll uncontrollably on its own.

### Braking Information

Your power chair is equipped with two powerful brake systems:

- Regenerative — uses electricity to rapidly slow the vehicle when the joystick returns to the centre/stop position.
- Disc Park Brake — activates mechanically after regenerative braking slows the vehicle to near stop, or when power is removed from the system for any reason.

### Cornering Information

While your power chair is equipped with caster wheels and anti-tip wheels, excessively high cornering speeds can still create the possibility of tipping. Factors which affect the possibility of tipping include, but are not limited to: cornering speed, steering angle (how sharply you are turning), uneven road surfaces, inclined road surfaces, riding from an area of low traction to an area of high traction (such as passing from a grassy area to a paved area – especially at high speed while turning), and abrupt directional changes. High cornering speeds are not recommended. If you feel that you may tip over in a corner, reduce your speed and steering angle (i.e., lessen the sharpness of the turn) to prevent your power chair from tipping.



**WARNING!** When cornering sharply, reduce your speed and maintain a stable centre of gravity. This greatly reduces the possibility of a tip or fall.

## II. SAFETY

### Public Streets and Roadways



**WARNING!** You should not operate your power chair on public streets and roadways. Be aware that it may be difficult for traffic to see you when you are seated on your power chair. Obey all local pedestrian traffic rules. Wait until your path is clear of traffic, and then proceed with extreme caution.

### Outdoor Driving Surfaces

Your power chair is designed to provide optimum stability under normal driving conditions—dry, level surfaces composed of concrete, blacktop, or tarmac. However, Pride recognises that there will be times when you will encounter other surface types. For this reason, your power chair is designed to perform admirably on packed soil, grass, and gravel. Feel free to use your power chair safely on lawns and in park areas.

- Avoid driving on uneven terrain and/or soft surfaces.
- Avoid tall grass that can entangle the running gear.
- Avoid loosely packed gravel and sand.
- If you feel unsure about a driving surface, avoid that surface.

### Inclement Weather Precautions

Exposure of your power chair to inclement weather conditions should be avoided whenever possible. If suddenly caught up in rain, snow, severe cold or heat while operating your power chair, proceed to shelter at the earliest opportunity. Thoroughly dry your power chair before storing, charging, or operating your power chair.



**PROHIBITED!** Operating in rain, snow, salt, mist/spray conditions, and on icy/slippery surfaces can have an adverse affect on the electrical system. Maintain and store your power chair in a dry and clean condition.



**WARNING!** Prolonged exposure to hot or cold conditions may affect the temperature of upholstered and non-upholstered items on the power chair, possibly resulting in skin irritation. Exercise caution when using your power chair in extremely hot or cold conditions or when exposing your power chair to direct sunlight for prolonged periods of time.

### Stationary Obstacles (Steps, Kerbs, etc.)

Proceed with extreme caution when driving near raised surfaces, unprotected ledges and/or drop-offs (kerbs, porches, stairs, etc.). Be sure your power chair is traveling perpendicular to any kerb you may be required to navigate.

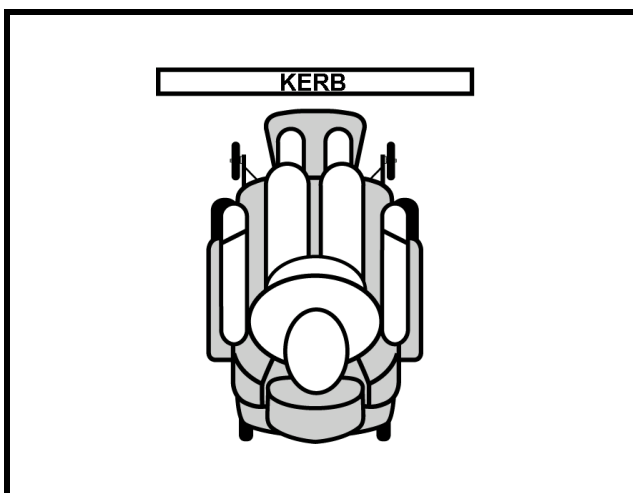

Figure 2. Correct Kerb Approach

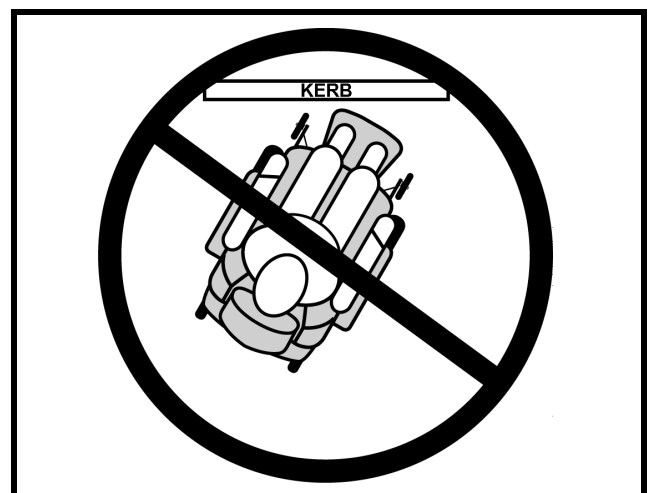

Figure 3. Incorrect Kerb Approach



## II. SAFETY

### To navigate up over a kerb or stationary obstacle:

1. Approach the kerb or obstacle slowly, and make sure the power chair is traveling perpendicular to the obstacle. See figure 2.
2. Increase the forward speed just before the front wheels come in contact with the obstacle.
3. Reduce the forward speed only after the rear wheels have cleared the obstacle.

### To navigate down a kerb or stationary obstacle:

1. Approach the kerb or obstacle slowly, and make sure the power chair is traveling perpendicular to the obstacle. See figure 2.
2. Reduce the forward speed just before the front wheels come in contact with the obstacle.
3. Increase the forward speed only after the rear wheels have cleared the obstacle and you are once again on a level surface.



**WARNING! Do not attempt to have your power chair climb or descend an obstacle that is higher than 5 cm (2 in) unless you have the assistance of an attendant.**

**WARNING! Do not attempt to have your power chair proceed rearward down any step, kerb, or other obstacle. This may cause the power chair to tip.**

### Stairs and Escalators

Power chairs are not designed to travel up or down stairs or escalators. Always use a lift.



**WARNING! Never use your power chair to negotiate steps or escalators.**

### Doors

- Determine if the door opens toward or away from you.
- Drive your power chair gently and slowly forward to push the door open. Or drive your power chair gently and slowly rearward to pull the door open.

### Lifts

Modern lifts have a door edge safety mechanism that, when pushed, reopens the lift door(s).

- If you are in the doorway of a lift when the door(s) begin to close, push on the rubber door edge or allow the rubber door edge to contact the power chair and the door will reopen.
- Use care that handbags, packages, or power chair accessories do not become caught in lift doors.

### Lift/Elevation Products

If you will be traveling with your power chair, you may find it necessary to use a lift/elevation product to aid in transportation. Pride recommends that you closely review the instructions, specifications, and safety information set forth by the manufacturer of the lift/elevation product before using that product.



**WARNING! Never sit on your power chair when it is being used in connection with any type of lift/elevation product. Your power chair was not designed with such use in mind and any damage or injury incurred from such use is not the responsibility of Pride.**

### Motor Vehicle Transport

Pride recommends that you do not remain seated in your power chair while traveling in a motor vehicle. The power chair should be stowed in the boot of a car or in the back of a truck or van with the batteries removed and properly secured. In addition, all removable power chair parts, including the armrests, seat, front riggings, controller, and shrouds should be removed and/or properly secured during motor vehicle transport.

**WARNING! Do not sit on your power chair while it is in a moving vehicle.**



**WARNING! Always be sure your power chair and its batteries are properly secured when it is being transported. Batteries should be secured in an upright position and protective caps should be installed on the battery terminals. Batteries should not be transported with any flammable or combustible items.**

## II. SAFETY

### Positioning Belts

Your Quantum Rehab Provider, therapist(s), and other healthcare professionals are responsible for determining your requirement for a positioning belt in order to operate your power chair safely.



**WARNING! If you require a positioning belt to safely operate your power chair, make sure it is fastened securely in order to reduce the possibility of a fall from the power chair.**

**WARNING! The positioning belt is not designed for use as a seat belt in a motor vehicle. Nor is your power chair suitable for use as a seat in any vehicle. Anyone traveling in a vehicle should be properly belted into seats approved by the vehicle manufacturer.**

### Batteries

In addition to following the warnings below, be sure to comply with all other battery handling information. For more information about your power chair's batteries, see VI. "Batteries and Charging."



**MANDATORY! Battery posts, terminals, and related accessories contain lead and lead compounds. Wear goggles and gloves when handling batteries and wash hands after handling.**

**WARNING! Power chair batteries are heavy. See specifications table. If you are unable to lift that much weight, be sure to get help. Use proper lifting techniques and avoid lifting beyond your capacity.**



**WARNING! Always protect the batteries from freezing and never charge a frozen battery. Charging a frozen battery may result in damage to the battery.**

**WARNING! Connect your battery harnesses in the proper manner. RED (+) cables must be connected to positive (+) battery terminals/posts. BLACK (-) cables must be connected to negative (-) battery terminals/posts. Protective caps should be installed over all battery terminals. REPLACE cables immediately if damaged.**

### Removable Parts



**WARNING! Do not attempt to lift or move a power chair by any of its removable parts, including the armrests, seat, front riggings, controller, and shrouds.**

### Preventing Unintended Movement



**WARNING! If you anticipate being seated in a stationary position for an extended period of time, turn off the power. This will prevent unexpected motion from inadvertent joystick contact. This will also eliminate the possibility of unintended chair movement from electromagnetic (EM) sources.**

### Reaching and Bending

Never reach, lean, or bend while driving your power chair. If it is absolutely necessary to reach, lean, or bend while seated on your power chair, it is important to maintain a stable centre of gravity and keep the power chair from tipping. Pride recommends that the power chair user determine his/her personal limitations and practice bending and reaching in the presence of a qualified healthcare professional.



**WARNING! Do not bend, lean, or reach for objects if you have to pick them up from the floor by reaching down between your knees or if you have to reach over the back of the seat. Movements such as these may change your centre of gravity and the weight distribution of the power chair, possibly causing your power chair to tip.**

**WARNING! Keep your hands away from the tyres when driving. Be aware that loose fitting clothing can become caught in drive tyres.**

## II. SAFETY

### Transfers

Transferring onto and off of your power chair requires a good sense of balance. Always have an attendant or healthcare professional present while learning to properly transfer yourself.

To eliminate the possibility of injury, Pride recommends that you or a trained attendant perform the following tasks before attempting a transfer:

- Turn off the power to the controller.
- Ensure your power chair is not in freewheel mode. See III. “Your Power Chair.”
- Turn the caster wheels toward the transfer destination to improve power chair stability during transfer.
- Make sure both armrests are flipped up or removed from your power chair.
- Flip up the foot platform or move the leg rests aside; this will help to keep your feet from getting caught on the front rigging during the transfer.
- Reduce the distance between your power chair and the object you are transferring onto.

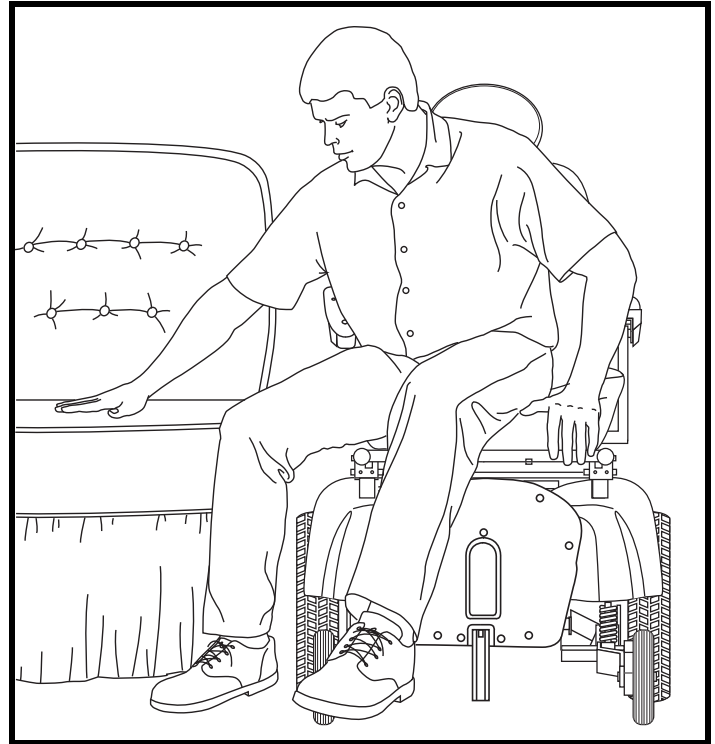

Figure 4. Ideal Transfer Position

**WARNING! Before transferring, position yourself as far back as possible in the power chair seat to prevent the power chair from tipping forward during transfer.**

**WARNING! Avoid putting all of your weight on the power chair armrests and do not use the armrests for weight bearing purposes, such as transfers. Such use may cause the power chair to tip, resulting in a fall from the power chair and personal injury.**



**WARNING! The controller and controller bracket are non-load bearing items on your power chair. Do not use the controller or controller bracket for weight bearing purposes, such as transfers. Such use may cause damage to these components, resulting in a fall from the power chair and personal injury.**

**WARNING! Avoid putting all of your weight on the front riggings. Such use may cause the power chair to tip.**

### Prescription Drugs/Physical Limitations

Users must exercise care and common sense when operating a power chair. This includes awareness of safety issues when taking prescribed or over-the-counter drugs or when the user has specific physical limitations.



**WARNING! Consult your physician if you are taking prescribed or over-the-counter medication or if you have certain physical limitations. Some medications and limitations may impair your ability to operate your power chair in a safe manner.**

## II. SAFETY

### Alcohol/Smoking

The power chair user must exercise care and common sense when operating his/her power chair. This includes awareness of safety issues while under the influence of alcohol or while smoking.

**WARNING! Do not operate your power chair while you are under the influence of alcohol, as this may impair your ability to operate your power chair in a safe manner.**



**WARNING! Although the power chair seat has passed the necessary testing requirements for cigarette smoke, Pride recommends that you adhere to the following safety guidelines:**

- **Do not leave lit cigarettes unattended.**
- **Keep ashtrays a safe distance from the seat cushions.**
- **Always make sure cigarettes are completely extinguished before disposal.**

### Electromagnetic and Radio Frequency Interference (EMI/RFI)



**WARNING! Laboratory tests have shown that electromagnetic and radio frequency waves can have an adverse affect on the performance of electrically-powered mobility vehicles.**

Electromagnetic and Radio Frequency Interference can come from sources such as cellular phones, mobile two-way radios (such as walkie-talkies), radio stations, TV stations, amateur radio (HAM) transmitters, wireless computer links, microwave signals, paging transmitters, and medium-range mobile transceivers used by emergency vehicles. In some cases, these waves can cause unintended movement or damage to the control system. Every electrically-powered mobility vehicle has an immunity (or resistance) to EMI. The higher the immunity level, the greater the protection against EMI. This product has been tested and has passed at an immunity level of 20 V/m.

**WARNING! Be aware that cell phones, two-way radios, laptops, and other types of radio transmitters may cause unintended movement of your electrically-powered mobility vehicle due to EMI. Exercise caution when using any of these items while operating your mobility vehicle and avoid coming into close proximity of radio and TV stations.**



**WARNING! The addition of accessories or components to the electrically-powered mobility vehicle can increase the susceptibility of the vehicle to EMI. Do not modify your power chair in any way not authorised by Pride.**

**WARNING! The electrically-powered mobility vehicle itself can disturb the performance of other electrical devices located nearby, such as alarm systems.**

*NOTE: For further information on EMI/RFI, go to the Resource Center on [www.pridemobility.com](http://www.pridemobility.com). If unintended motion or brake release occurs, turn your power chair off as soon as it is safe to do so. Contact your Quantum Rehab Provider to report the incident.*

# III. YOUR POWER CHAIR

## THE QUANTUM 1121

The power chair has two main assemblies: the seat and the power base. See figures 5 and 6. Typically, the seat assembly includes the armrests, seatback, and seat base. The power base assembly includes two motor/brake assemblies, two drive wheels, two anti-tip wheels, two caster wheels, two batteries, and wiring harnesses.

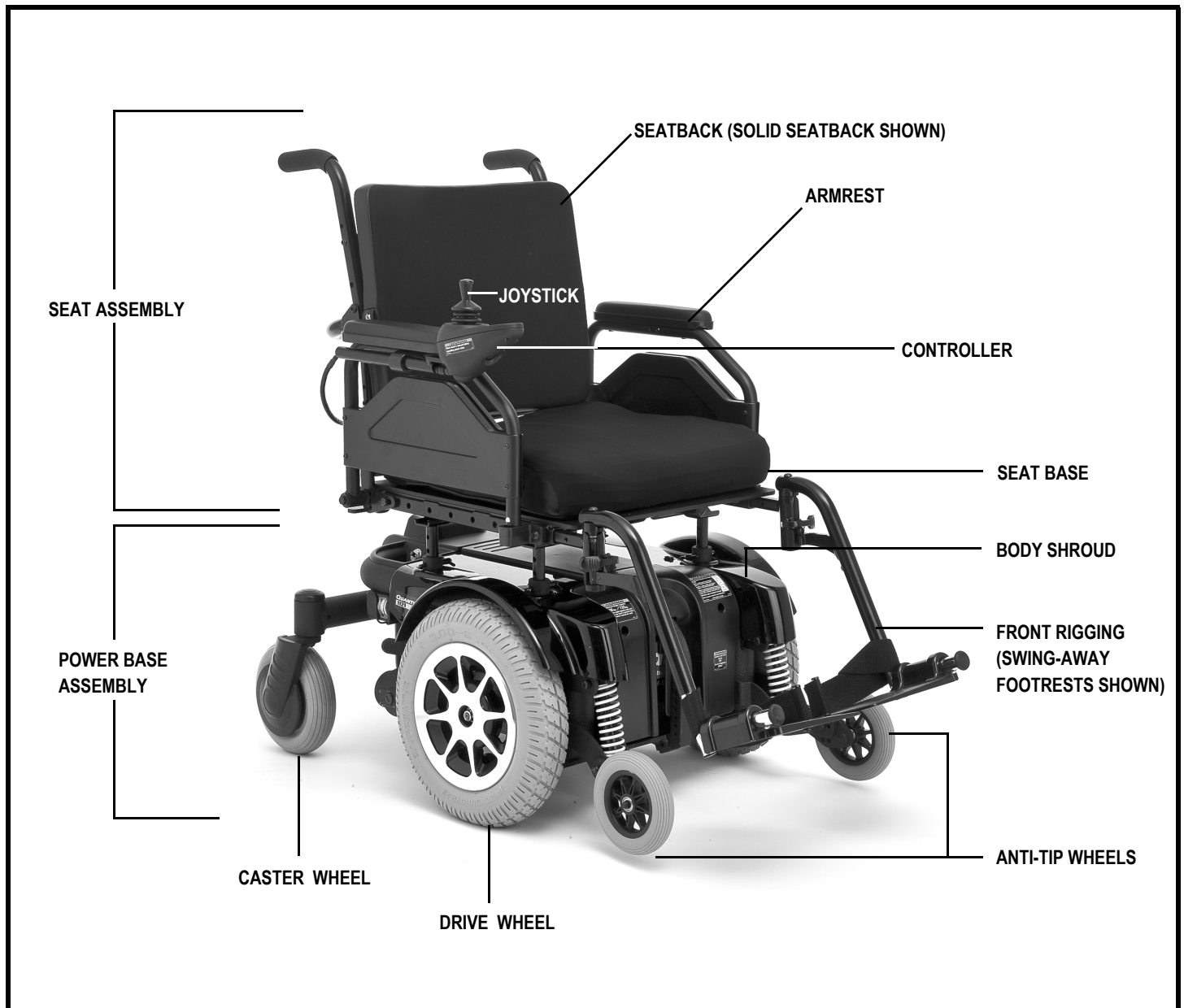

Figure 5. The Quantum 1121

# III. YOUR POWER CHAIR

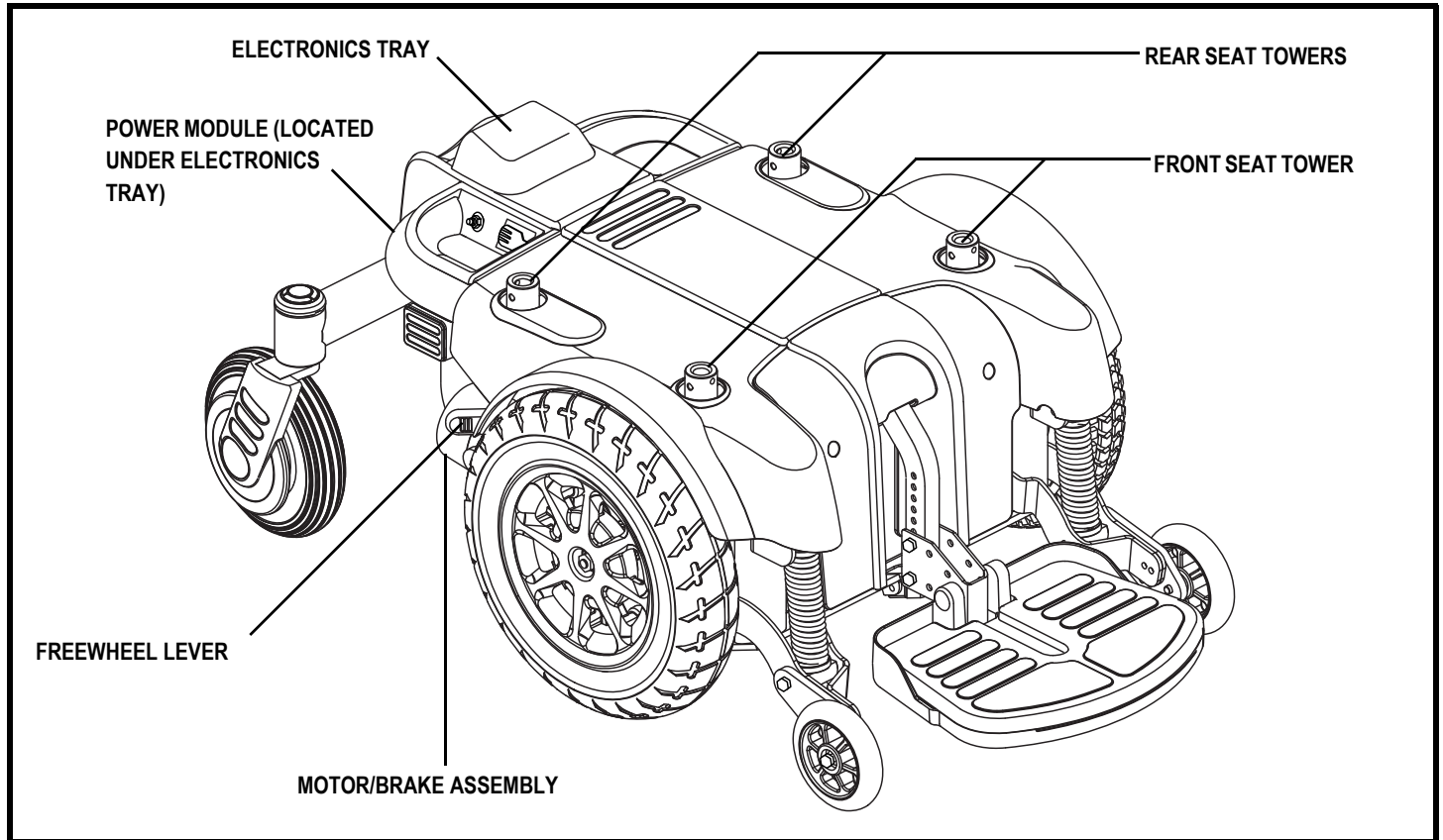

Figure 6. The Quantum 1121 Power Base

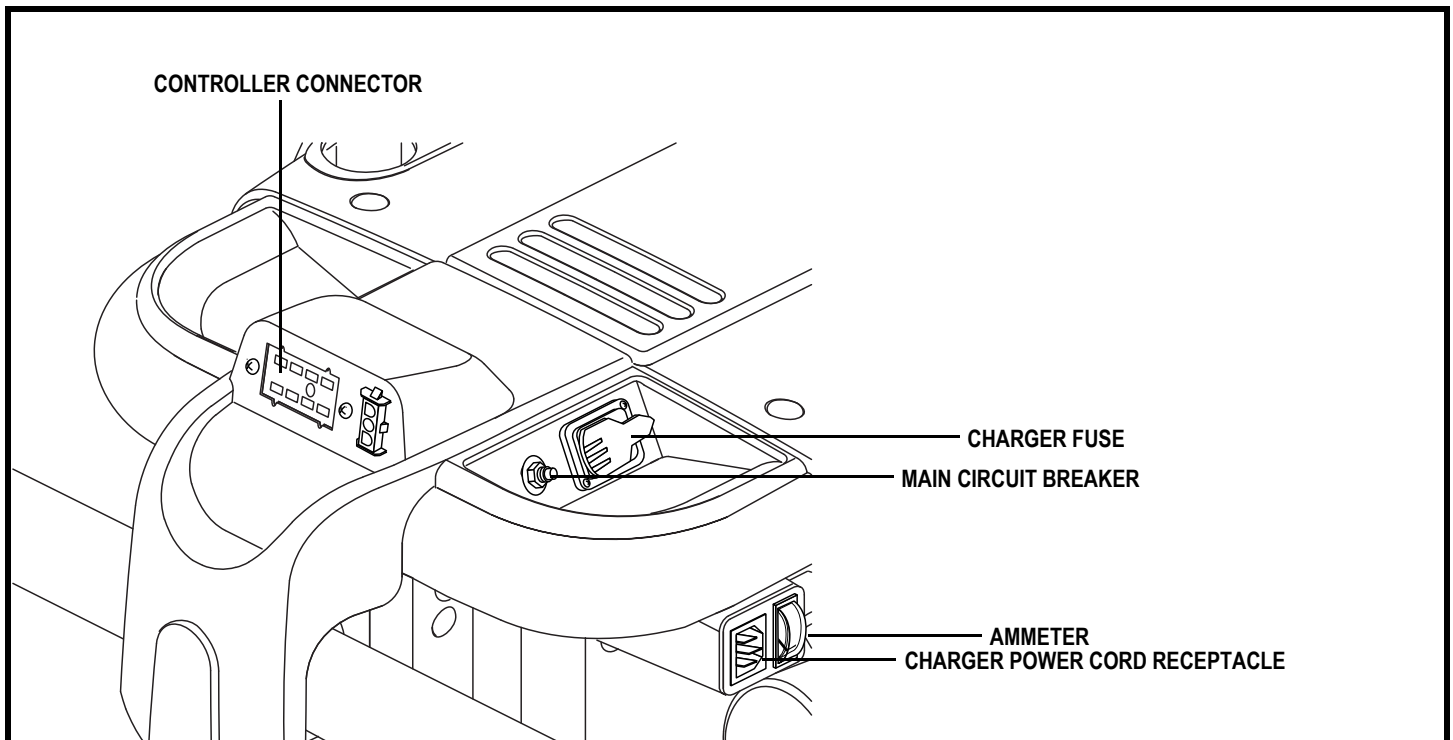

Figure 7. The Quantum 1121 Series Electronics Tray (Optional Onboard Charging System Shown)

## III. YOUR POWER CHAIR

### Electronics Tray

The electronics tray is located on the back of the power base. See figures 6 and 7. The ammeter, the optional onboard charger, the charger power cord receptacle, the main circuit breaker, the controller connector, and the charger fuse are all located on the electronics tray.

**Ammeter:** The ammeter displays the charger's current output in amps. See VI. "Batteries and Charging."

**Charger Power Cord Receptacle (with optional onboard charger):** This is where the charger power cord plugs into the power base.

**Main Circuit Breaker:** The main circuit breaker is a safety feature built into your power chair. When the batteries and the motors are heavily strained (e.g., from excessive loads), the main circuit breaker trips to prevent damage to the motors and the electronics. If the circuit trips, allow your power chair to "rest" for approximately one minute. Next, push in the circuit breaker button, turn on the controller, and continue normal operation. If the main circuit breaker continues to trip repeatedly, contact your Quantum Rehab Provider.

**Controller Connector:** This is where the controller connects to the power base. Each controller uses a different type of cable. Regardless of which type of controller is used, the cable must be secured to the seat assembly and not allowed to drag on the floor.

**Charger Fuse (with optional onboard charger):** The charger fuse protects the ammeter from current overload. There are three fuses on the utility tray. The top one is the charger fuse. The bottom two are spares.

### Active-Trac Suspension

The Quantum 1121 is equipped with Active-Trac Suspension (ATS). ATS is a suspension system designed to make your power chair traverse different types of terrain and obstacles while maintaining smooth operation. With ATS, the front anti-tip wheels work in conjunction with the motor suspension to help you maneuver over obstacles in excess of 7.62 cm (3 in.) in height.

As the front anti-tip wheels come in contact with an obstacle, the front anti-tip wheel assembly is drawn upward. At the same time, the motors are forced downward. This allows the motors to push the power chair over an obstacle without the possibility of becoming "hung up" on the obstacle.

ATS also helps in day-to-day operating conditions. For instance, when you release the joystick, your power chair begins to slow down. As the chair slows down, the front anti-tip wheels will automatically drop toward the ground. This will reduce the forward tip that is typically encountered with centre-wheel drive chairs.

# III. YOUR POWER CHAIR

## Manual Freewheel Lever

For your convenience, your power chair is equipped with a manual freewheel system. This system consists of one or more freewheel levers which enable you to disengage the drive motors and maneuver the chair manually.



**WARNING! Do not use your power chair while the drive motors are disengaged unless you are in the presence of an attendant! Do not disengage the drive motors when your power chair is on an incline or decline, as the unit could roll on its own. Only engage the freewheel mode when on a level surface.**

**WARNING! It is important to remember that when your power chair is in freewheel mode, the braking system is disengaged.**

### To operate the dual manual freewheel levers:

1. Push the manual freewheel lever on each motor down for freewheel mode (drive disengaged). See figure 8.
2. Pull the manual freewheel lever up on each motor for drive mode (drive engaged). See figure 9.

If a lever is difficult to move in either direction, rock your power chair back and forth slightly. The lever should then move to the desired position.



**WARNING! Do not use the freewheel lever handles as tie-down points to secure this product.**

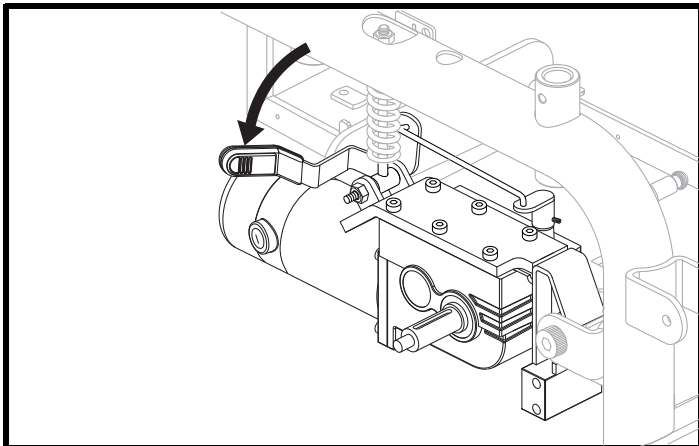

Figure 8. Freewheel Mode (Drive Disengaged)

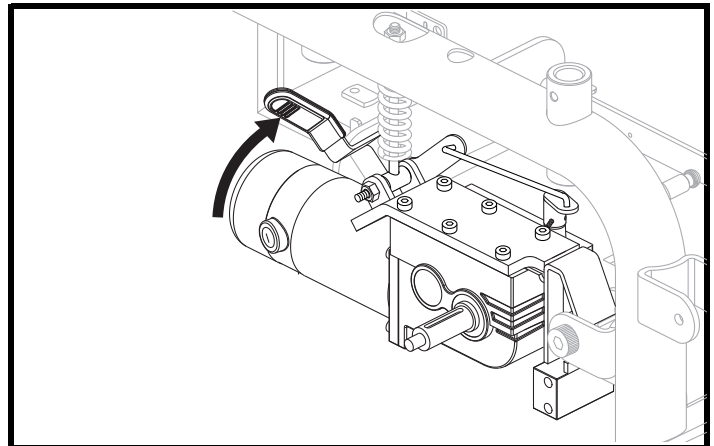

Figure 9. Drive Mode (Drive Engaged)



# IV. ASSEMBLY

## INITIAL ASSEMBLY

Your power chair may require some assembly either before initial use or after transportation. It may also require disassembly to make some comfort adjustments.

**NOTE:** Any nylon insert lock nut removed during the disassembly or adjustment of the power chair must be replaced with a new nut. Nylon insert lock nuts should not be reused as it may cause damage to the nylon insert, resulting in a less secure fit. Replacement nylon insert lock nuts are available at local hardware stores or through your Quantum Rehab Provider.

## Seat Installation

The Universal Mounting System (UMS) consists of universal parts that may be used on the Specialty Seat or any high-back seat, regardless of seat width or seat depth. The two main components are aluminum extrusions that can be mounted to the seat base. These extrusions attach to a pair of trapeze bars that are mounted to four steel towers. If your power chair is equipped with a Specialty Seat, Synergy Seat, or Synergy TRU-Balance, refer to the information provided in separate manuals. If your power chair is equipped with a high-back seat, a reclining seat, or a power elevating seat, refer to the following information.



**WARNING!** Do not pick up the seat frame by the armrests. They are free to pivot, and you may lose control of the seat if they do so.

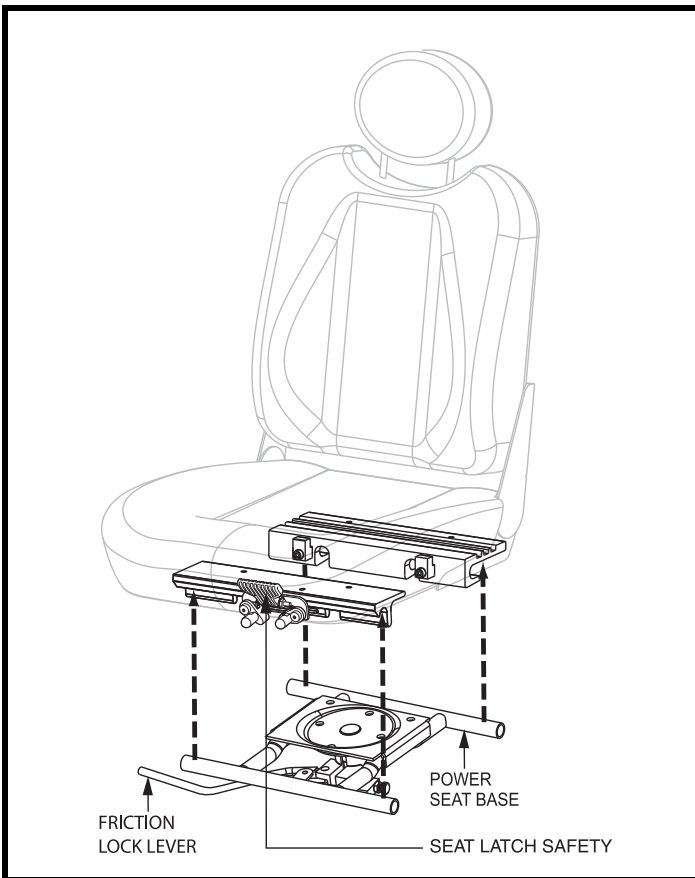

Figure 10. Universal Mounting System (Power Seat)

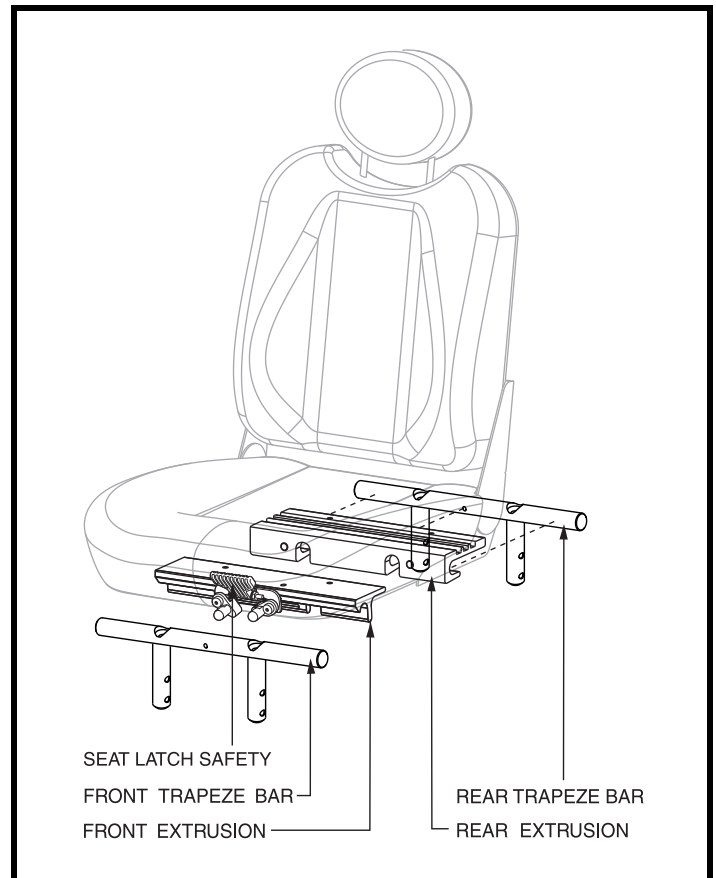

Figure 11. Universal Mounting System

## IV. ASSEMBLY

### To install the seat:

1. Set the seat towers to the desired height. To change the seat height, see V. "Comfort Adjustments."
2. Tilt the seat back, and slide the rear extrusion onto the rear trapeze bar.
3. Lower the front extrusion onto the front trapeze bar until the seat locks into place..
4. Flip the seat latch safety down.



**WARNING! Make sure the seat latch safety is flipped down before using your power chair.**

5. Install the controller into one of the armrests. See V. "Comfort Adjustments."
6. Plug the controller cable(s) into the connector on the electronics tray.
7. Route the cable to ensure that the cable cannot be pinched in the seat hinge. See figure 12 or 13.
8. Secure the controller cable to the armrest receiver with one or more wire ties. See figure 12.



**MANDATORY! Prevent controller harness damage! Avoid routing the controller harness on the outside of the armrest pad. Route the harness under the armrest or toward the inside of the armrest pad. Use correct tie-down points for the controller harness to prevent the harness from getting caught in the drive tires, pinched in the seat frame, or damaged when passing through doorways.**

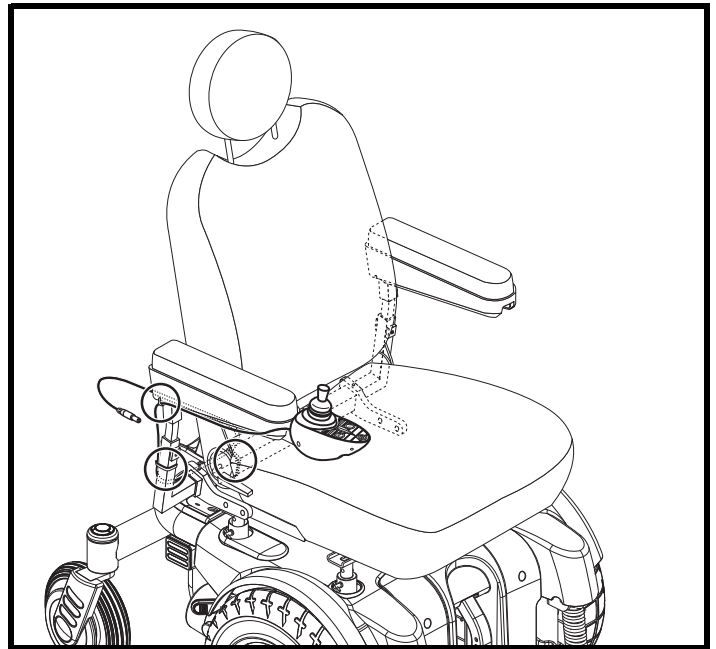

Figure 12. Cable Routing - Contour Seat

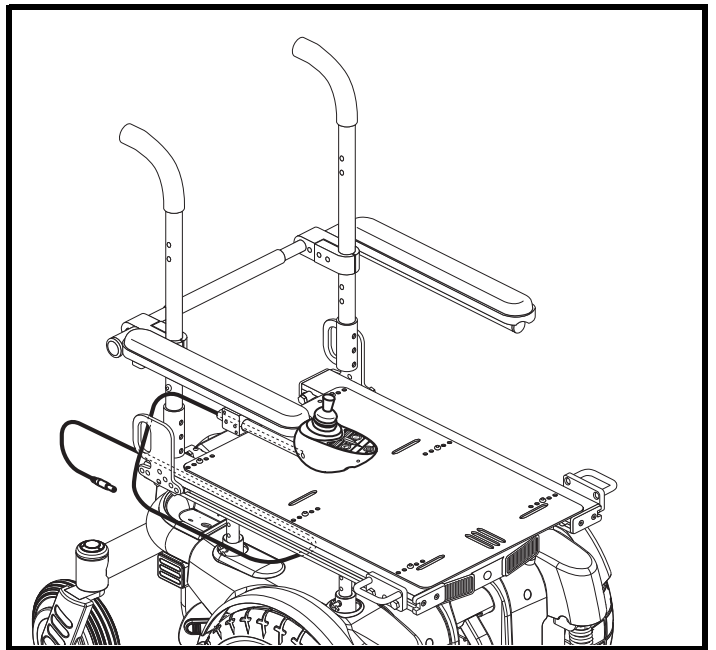

Figure 13. Cable Routing - Synergy Seat

# V. COMFORT ADJUSTMENTS

## COMFORT ADJUSTMENTS

After becoming familiar with your power chair's operation, you may find the need to make some adjustments to increase your comfort, such as seat height and angle, armrest angle, foot platform height and angle, and the controller's position.

**NOTE:** *If your power chair is equipped with a Specialty Seat, Synergy Seat, or Synergy TRU-Balance, refer to the information provided in separate manuals. If your power chair is equipped with a contoured seating system, refer to the following information.*

**WARNING!** The centre of gravity of your power chair was factory set to a position that meets the needs of the demographic majority of users. Your Quantum Rehab Provider has evaluated your power chair and made any necessary adjustments to suit your specific requirements. Do not change your seating configuration without first contacting Pride Mobility Products or your Quantum Rehab Provider.



**WARNING!** Some power chair components are heavy. You may need assistance to lift or carry them. Please refer to the specifications table for specific component weights before you disassemble the power chair.

**WARNING!** Remove the occupant from the power chair before making any adjustments.

You may need the following to make comfort adjustments:

- metric/standard hex key set
- metric/standard socket set and ratchet
- adjustable spanner

### Seat Height and Seat Angle Adjustment

There are four steel towers that connect the seat to the power base. See figure 6. You can change the seat height to one of three positions by raising the seat towers. If you raise or lower only one set of seat towers (front or rear), you can also change the seat base angle.

**NOTE:** *If your power chair is equipped with a power elevating seat, then you change the seat height through the controller or a switch.*

#### To change the seat height:

1. Turn off the power to the controller.
2. Unplug the controller connector(s) from the electronics tray.
3. Flip up the seat latch safety. See figure 14.
4. Squeeze the seat latch and release the seat from the front trapeze bar.
5. Slide the seat forward and remove it from the power base.
6. Remove the retaining clip from each of the four seat towers. See figure 15.
7. Move the trapeze bars up or down to the desired height.

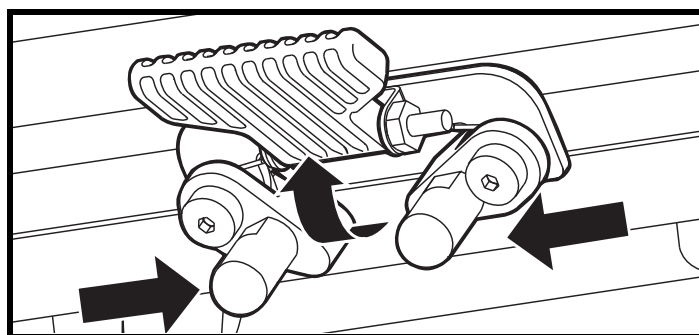

Figure 14. Seat Latch Safety (Disengaged)

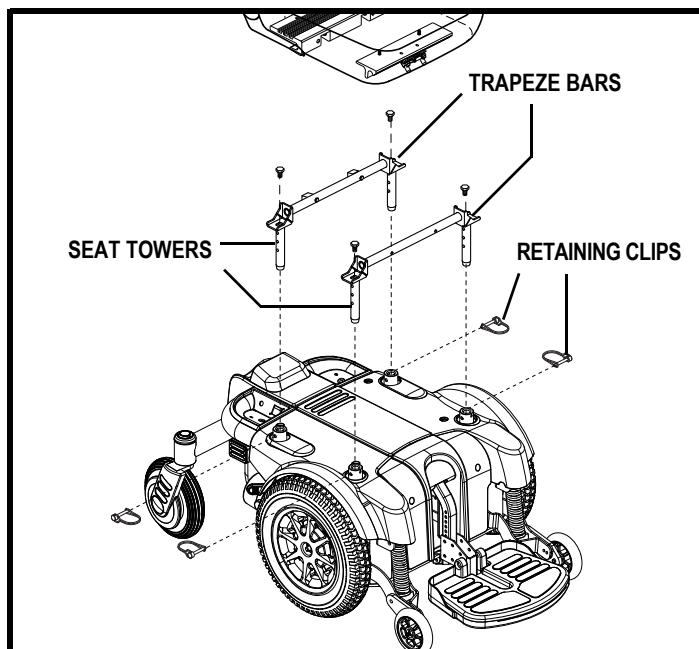

Figure 15. Seat Height Adjustment

# V. COMFORT ADJUSTMENTS

8. Reinstall the retaining clip into each seat tower.
9. Reinstall the seat.
10. Plug the controller connector(s) into the electronics tray.

**NOTE:** Make sure the seat latch safety is flipped down before using the power chair seat.

## Seat Position Adjustment

You can move the seat forward or rearward by changing the extrusion mounting position.

### To change the position:

1. Turn off the power to the controller.
2. Remove the seat.
3. Remove both extrusions from the bottom of the seat. See figure 10.
4. Reposition the extrusions on a different set of mounting holes. You must move both extrusions the same number of holes either forward or rearward. See figure 16.
5. Fasten the extrusions back onto the bottom of the seat.
6. Reinstall the seat.

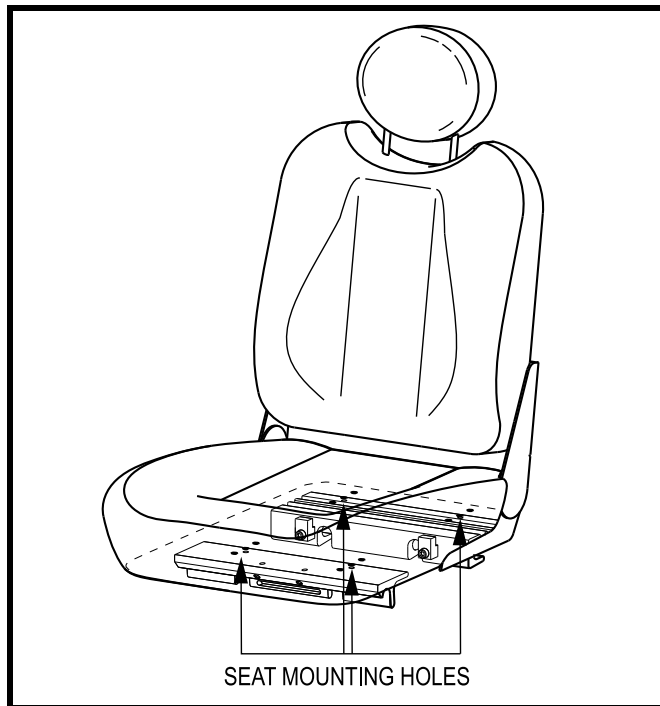

Figure 16. Seat Position Adjustment

## Manual Recline Seatback Adjustment

If your power chair is equipped with a reclining seat, you can adjust the seatback angle with the seatback release lever. The lever is located on the right side of the seat base.

### To adjust the seatback angle:

1. Pull up on the seatback release lever.
2. Move the seatback down or up to the desired position.
3. Release the lever.

## Seatback Angle Adjustment

If your power chair is equipped with an adjustable seatback, you can adjust it to four (4) different angles: 90°, 102°, 105°, or 107°.

### To adjust the seatback angle:

1. Remove the seatback angle adjustment screws on both seat hinges. See figure 17.
2. Set the seatback at the desired angle.
3. Reinstall the screws to both seat hinges and tighten.

# V. COMFORT ADJUSTMENTS

## Armrest Width Adjustment

You can change each armrest's width independently of each other.

**NOTE:** Changing the armrest width may increase the overall width of your power chair.

### To change the armrest width:

1. Locate the two armrest knobs on each side of the armrest receiver bracket. See figure 17.
2. Loosen the knobs.
3. Slide the armrests in or out to the desired width.
4. Tighten the knobs.

## Armrest Height Adjustment

### To change the armrest height:

1. Loosen the two setscrews located on the armrest receiver.
2. Raise or lower the armrest to the desired height. See figure 17.
3. Tighten the setscrews to secure the armrest.

## Armrest Angle Adjustment

### To change the armrest angle:

1. Lift the armrest straight up so that it is perpendicular to the floor.
2. Loosen the locking nuts. See figure 17.
3. Loosen the armrest angle adjustment screw.
4. Turn the adjustment screw to raise the front of the armrest or to lower the front of the armrest. See figure 17.
5. Tighten the locking nuts to lock the adjustment screw into place.

## Controller Position

You can move the controller in toward or out away from the armrest, or change the position of the controller for either left-hand or right-hand use.



**WARNING!** Do not place the controller cable so that it can be pinched in the seat frame or the power base frame.

### To extend the controller:

1. Flip up the armrest so it is perpendicular to the floor.
2. Loosen the setscrew on the controller bracket. See figure 18.
3. Slide the controller into or out of the armrest to the desired position.
4. Tighten the setscrew.

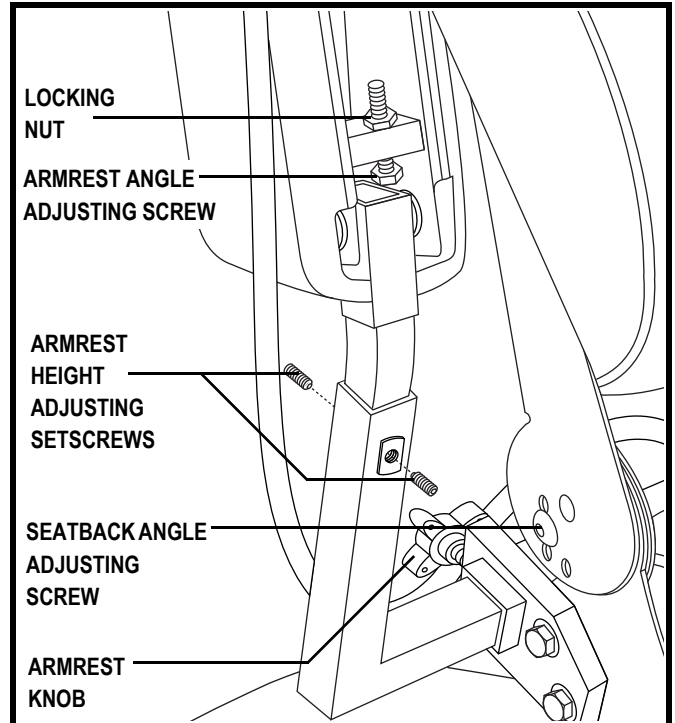

Figure 17. Seatback and Armrest Adjustments

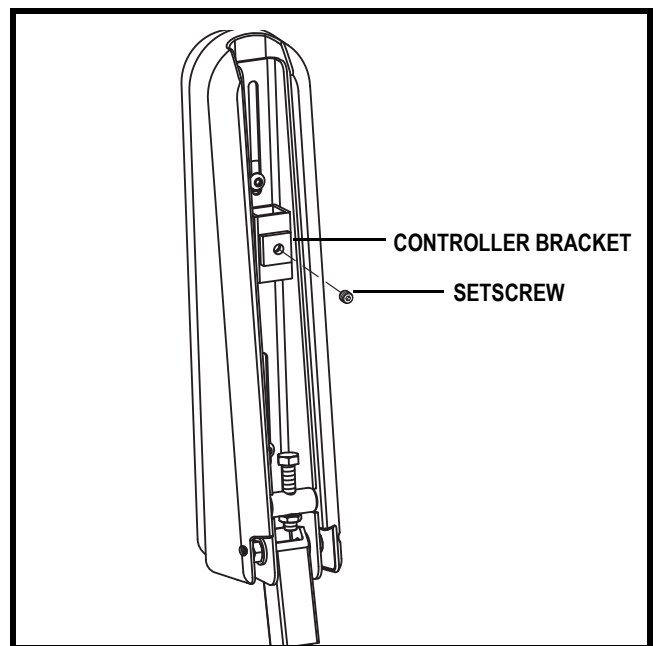

Figure 18. Controller Adjustment

# V. COMFORT ADJUSTMENTS

## To change the controller position:

1. Turn off the power to the controller.
2. Unplug the controller connector from the power base.
3. Remove any wire ties securing the controller cable to the armrest.
4. Flip up the armrest so it is perpendicular to the floor.
5. Loosen the setscrew on the controller bracket
6. Slide the controller out of the armrest.
7. Loosen the setscrew in the other armrest.
8. Place the controller in the other armrest.
9. Tighten the setscrew to secure the controller.
10. Route the controller cable to the back of the power base and plug in the controller.
11. Secure the controller cable to the armrest with wire ties. See figure 12.

**NOTE:** If your power chair is equipped with a Specialty Seat, Synergy Seat, or TRU-Balance Power Positioning System, loosen the mounting screws in the mounting block, transfer the mounting block and controller to the opposite armrest, and tighten the mounting screws. See figure 19.

## Foot Platform Height Adjustment

The foot platform height is easily adjusted to one of several different heights.

### To raise or lower the foot platform:

1. Remove the nuts and bolts from the foot platform bracket. See figure 20.
2. Raise or lower the foot platform to the desired height.
3. Reinstall the nuts and bolts into the foot platform bracket and tighten.

## Foot Platform Depth Adjustment

### To adjust the foot platform depth:

1. Remove the nuts and bolts from the foot platform bracket. See figure 20.
2. Move the foot platform in or out to the desired depth.
3. Reinstall the nuts and bolts into the foot platform bracket and tighten.

## Foot Platform Angle Adjustment

You can adjust the angle of the foot platform with a hex key. See figure 21.

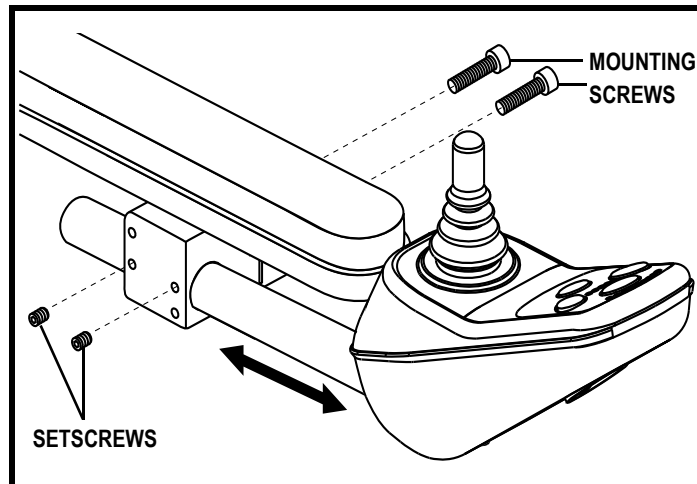

Figure 19. Controller Position Mounting Bracket

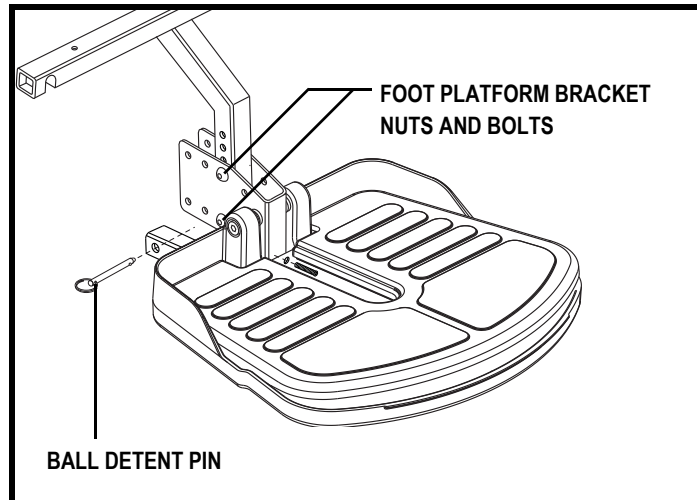

Figure 20. Foot Platform Height Adjustment

# V. COMFORT ADJUSTMENTS

## To adjust the foot platform angle:

1. Locate the setscrew on the underside of the foot platform.
2. Turn the setscrew to raise or lower the front of the foot platform.

## Anti-Tip Wheels

The anti-tip wheels are designed to give your power chair increased stability on rough surfaces. The anti-tip wheels are preset for smooth surfaces or indoor use only. If you plan on using your power chair on rough surfaces, it may be necessary to adjust the anti-tip wheels to better suit your needs. The anti-tip wheels may need adjustment if either of the following occur:

- When coming to a stop, your power chair tips forward excessively.
- The anti-tip wheels constantly rub the ground.

**WARNING! Consult your Quantum Rehab Provider before attempting to change the anti-tip wheel height! Changing the anti-tip wheel height affects handling under deceleration!**



**WARNING! The higher you raise the anti-tip wheels, the more you increase your power chair's tendency to tilt forward when coming to a stop. You can compensate for this by having your Quantum Rehab Provider make a small adjustment to the pre-programmed deceleration setting in the controller or by moving the seat assembly further to the rear of your power chair.**



**PROHIBITED! Do not remove the anti-tip wheels.**

## To adjust the anti-tip wheels:

1. Remove the anti-tip wheel.
2. Remove the nut and bolt on the anti-tip bracket. See figure 22.
3. Raise or lower the anti-tip wheel.
4. Reinstall the nut and bolt on the anti-tip bracket.
5. Reinstall the wheel.
6. Raise or lower the other anti-tip bracket so that it is at the same height.

**NOTE: Each drive tyre must be inflated to the air pressure rating on the side of the tyre in order for the anti-tip wheels to be properly adjusted.**

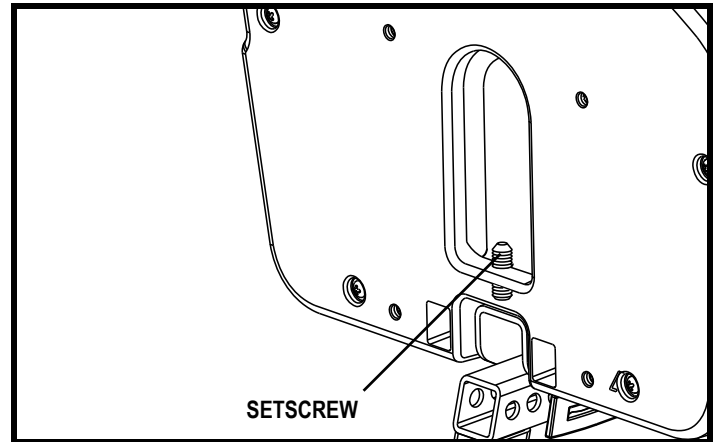

Figure 21. Foot Platform Angle Adjustment

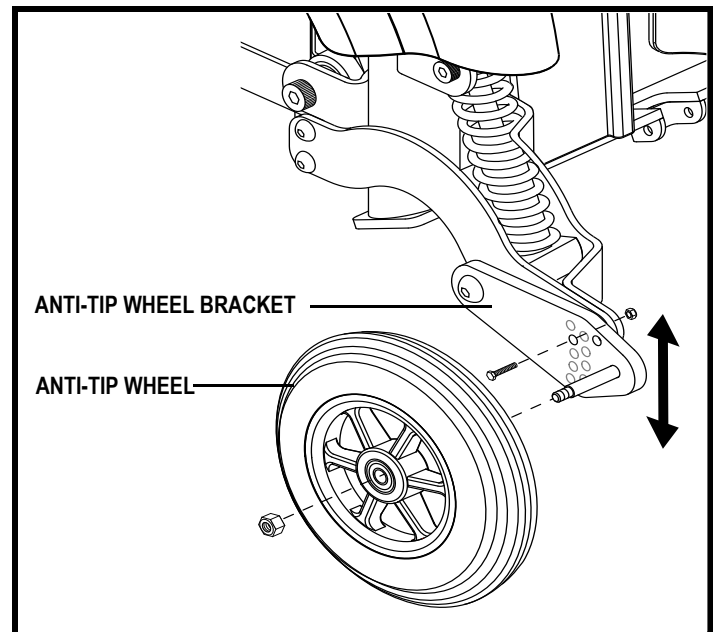

Figure 22. Anti-Tip Wheel Assembly

# V. COMFORT ADJUSTMENTS

## Power Elevating Seat Option

Your power chair may be equipped with a power elevating seat actuator. See figure 23. The power elevating seat is equipped with a speed inhibit system that reduces power chair speed by one-half whenever the seat is elevated more than 2.54-5cm (1–2 in.). Always check to be sure the speed inhibit system is operating properly before using your power chair, and do not move around in your seat to any great extent when the seat is in the raised position.

The power elevating seat can enhance the capabilities of the power chair in several ways:

- By raising the seat, you extend your level of reach to allow more freedom and independence in many environments.
- You can easily adjust the seat height to any surface to which you want to transfer. The seat swivels 90 degrees to whichever side the joystick is located.
- By raising the seat, you are closer to the eye level of standing persons. This provides better interaction.

For all the benefits your power elevating seat system can provide you, there are limitations.

**WARNING! Always fasten the positioning belt when operating the power elevating seat system.**

**WARNING! The power elevating seat is intended for use on a level surface only. Never raise the power elevating seat from its lowest position on an inclined surface. Failure to heed this warning can result in the power chair tipping over.**



**WARNING! Never raise the power elevating seat from its lowest position when operating your power chair on bumpy or uneven surfaces. Failure to heed this warning can result in the power chair tipping over.**

**WARNING! Never raise the power elevating seat while your power chair is in freewheel mode.**

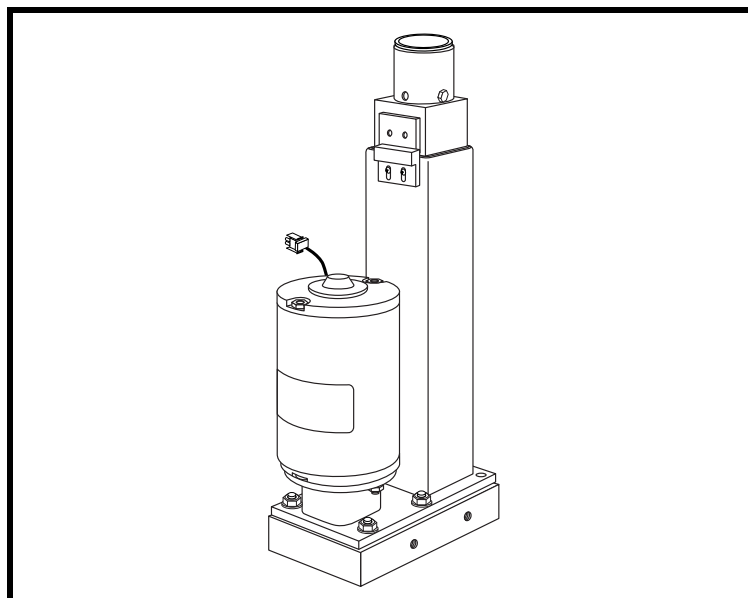

Figure 23. Power Elevating Seat Actuator



# V. COMFORT ADJUSTMENTS

## Power Elevating Seat Operation

You can control the power elevating seat through either the toggle switch located on the armrest (see figure 24) or through the controller. For information on how to raise and lower the power elevating seat through your controller, contact your Quantum Rehab Provider.

### To operate the power elevating seat through toggle switch:

1. Push the toggle switch forward to raise the seat. When you release the toggle switch, the seat will stop. Once the seat reaches its highest extension, the lift action will stop, but you should continue to hear and/or feel the lift motor running. This is because there is a clutch mechanism that allows the motor to continue running after the lift has reached its limit. This clutch works at both the top and bottom extensions of the lift.

**NOTE:** Do not allow the motor to run more than a few seconds after the mechanism reaches the top or bottom limit.

2. Pull the toggle switch rearward to return the seat to its lowest position. When returning to the lowest position, always be sure that the mechanism has reached its lowest limit.

### To use the swivel feature:

1. Locate the friction lock lever under the seat. See figure 10.
2. Pull back on the friction lock lever and rotate the seat 90° to whichever side the controller is located.
3. Push the friction lock lever forward to lock the seat in place.



**WARNING!** Do not attempt to drive the power chair with the seat facing to the side. Always return the seat to the forward facing position before operating the power chair.

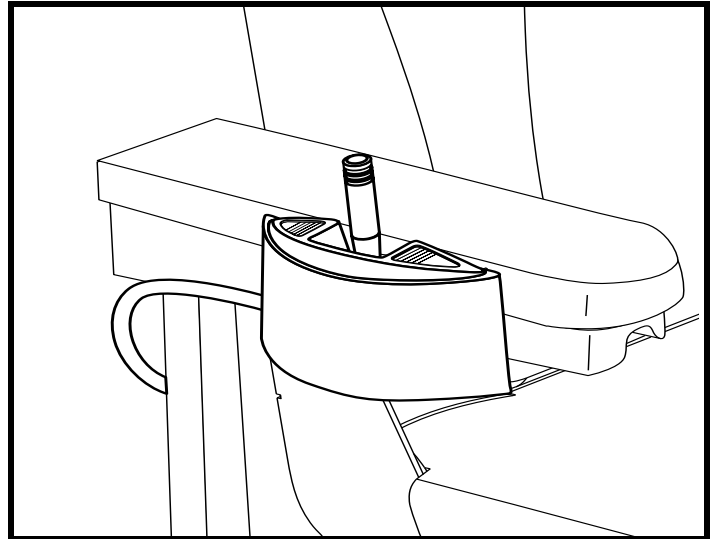

Figure 24. Toggle Switch

# VI. BATTERIES AND CHARGING

## BATTERIES AND CHARGING

The power chair uses two long-lasting, 12-volt, deep-cycle batteries. These batteries are sealed and maintenance free. Since they are sealed, there is no need to check the electrolyte (fluid) level. Deep-cycle batteries are designed to handle a longer and deeper discharge. Though they are similar in appearance to automotive batteries, they are not interchangeable. Automotive batteries are not designed to handle a long, deep discharge, and also are unsafe for use in power chairs.



**MANDATORY!** Battery posts, terminals, and related accessories contain lead and lead compounds. Wear goggles and gloves when handling batteries and wash hands after handling.



**WARNING!** Always use two batteries of the exact same type, chemistry, and amp-hour (Ah) capacity. Refer to the specifications table in this manual and in the manual supplied with the battery charger for recommended type and capacities.

**WARNING!** Contact your Quantum Rehab Provider if you have any questions regarding the batteries in your power chair.

## Charging the Batteries

The battery charger is essential in providing long life for your power chair batteries. It is designed to optimise your power chair's performance by charging the batteries safely, quickly, and easily. The battery charging system consists of the battery charger, the charger circuit fuse, and the ammeter (optional onboard chargers only). The ammeter indicates the rate of charge necessary to fully recharge the batteries. It is also a good indication of whether or not the charger is working. The ammeter and the charger are only functional when the charger power cord is plugged into an electrical outlet.

**PROHIBITED!** Removal of grounding prong can create electrical hazard. If necessary, properly install an approved 3-pronged adapter to an electrical outlet having 3-pronged plug access.



**PROHIBITED!** Never use an extension lead to plug in your battery charger. Plug the charger directly into a properly wired standard electrical outlet.

**PROHIBITED!** Do not allow unsupervised children to play near the power chair while the batteries are charging. Pride recommends that you do not charge the batteries while the power chair is occupied.



**MANDATORY!** Read the battery charging instructions in this manual and in the manual supplied with the battery charger before charging the batteries.

**WARNING!** You must recharge your power chair's batteries with the supplied off-board battery charger. Do not use an automotive-type battery charger.

**WARNING!** Do not expose the battery charger to rain or other sources of moisture unless it has been tested for outdoor use. Refer to the manual supplied with the battery charger for more information.

**WARNING!** Explosive gases may be generated while charging the batteries. Keep the power chair and battery charger away from sources of ignition such as flames or sparks and provide adequate ventilation when charging the batteries.



**WARNING!** Inspect the battery charger, wiring, and connectors for damage before each use. Contact your Quantum Rehab Provider if damage is found.

**WARNING!** Do not attempt to open the battery charger case. If the battery charger does not appear to be working correctly, contact your Quantum Rehab Provider.

**WARNING!** If the battery charger is equipped with cooling slots, then do not attempt to insert objects through these slots.

**WARNING!** If your battery charger has not been tested and approved for outdoor use, then do not expose it to adverse or extreme weather conditions. If the battery charger is exposed to adverse or extreme weather conditions, then it must be allowed to adjust to the difference in environmental conditions before use indoors. Refer to the manual supplied with the battery charger for more information.

## VI. BATTERIES AND CHARGING

### To charge the batteries using the off-board charger:

1. Position the front of your power chair next to a standard electrical outlet. See figure 25.
2. Be certain the controller power is turned off and the power chair is in drive mode.
3. Plug the off-board charger into the off-board charger/programming socket on the controller.
4. Plug the off-board charger into the electrical outlet.

**NOTE:** *If it is a Pride off-board charger, then there are two lights in it. The red light indicates that power to the off-board charger is on. The green light indicates that the batteries are fully charged. If it is not a Pride off-board charger, then follow the instructions supplied by the manufacturer.*

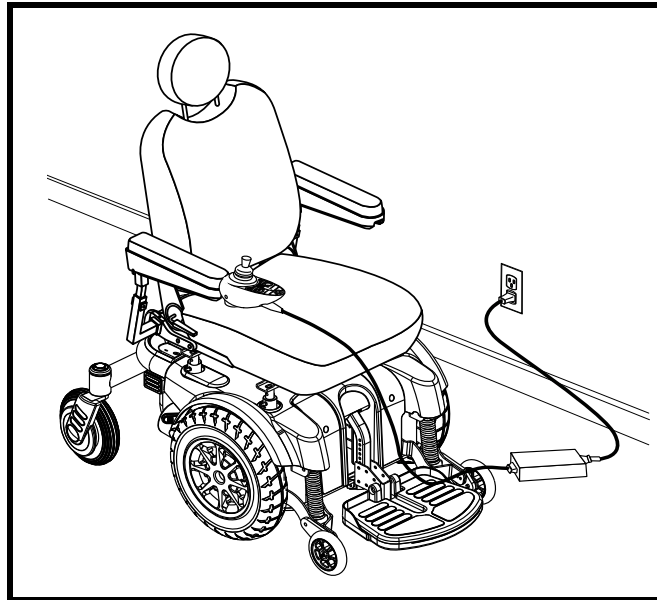

Figure 25. Battery Charging

5. When the batteries are fully charged, unplug the off-board charger from the electrical outlet and then from the controller.

### To charge the batteries using the optional onboard charger:

1. Position the rear of your power chair close to a standard electrical outlet.
2. Be certain the controller power is turned off and the freewheel levers are in the engaged position. See III. "Your Power Chair."
3. Plug the charger power lead into the charger power lead receptacle on the power base (see figure 7), then into the electrical outlet.

**NOTE:** *The power chair incorporates an inhibit function that disables the power chair when the charger is plugged into an electrical outlet.*

4. We recommend you charge the batteries for 8 to 14 hours. As the batteries charge, the ammeter needle slowly drops to 0.

**NOTE:** *The ammeter indicates how much charge is needed to fully charge the batteries. As the batteries charge, the ammeter needle slowly drops to 0. When the batteries are fully charged, the needle vibrates on or about the 0 mark on the ammeter.*

5. When your power chair's batteries are fully charged, disconnect the charger power lead, wind up the lead, and store it in a safe place.

### Battery Break-in

#### To break in new batteries for maximum efficiency:

1. Fully recharge any new battery prior to its initial use. This brings the battery up to about 90% of its peak performance level.
2. Operate your power chair throughout the house and grounds. Move slowly at first, and do not travel too far until you become accustomed to the controls and break in the batteries.
3. Give the batteries another full charge of 8 to 14 hours and operate your power chair again. The batteries will now perform at over 90% of their potential.
4. After four or five charging cycles, the batteries will top off at 100% charge and last for an extended period.

# VI. BATTERIES AND CHARGING

## Frequently Asked Questions (FAQs)

### How does the charger work?

The battery charger takes the standard electrical outlet voltage (alternating current) and converts it to 24 VDC (direct current). The power chair batteries use direct current to run your power chair. When the battery voltage is low, the charger works harder to charge the battery. As the battery voltage approaches full charge, the charger doesn't work as hard to complete the charging cycle. When the battery is fully charged, the amperage from the charger is nearly at zero. This is how the charger maintains a charge but does not overcharge the battery.

### Can I use a different battery charger?

You should use the charger supplied with the power chair. It is the safest, most efficient tool to charge the batteries. We do not recommend using other types of chargers (e.g., an automotive battery charger).

**NOTE:** *Your power chair's charger will not operate after the batteries have been discharged to nearly zero voltage. If this happens, call your Quantum Rehab Provider for assistance.*

### How often must I charge the batteries?

Many factors come into play when deciding how often to charge the batteries. You may use your power chair all day on a daily basis or you may not use it for weeks at a time.

#### ■ Daily Use

If you use your power chair on a daily basis, charge the batteries as soon as you are finished using your power chair. Your power chair will be ready each morning to give you a full day's service. It is recommended that you charge the batteries 8 to 14 hours after daily use.

#### ■ Infrequent Use

If you use your power chair infrequently (once a week or less), you should charge the batteries at least once per week for 12 to 14 hours.

**NOTE:** *Keep your batteries fully charged and avoid deeply discharging your batteries. Do not charge the batteries for more than 24 hours at a charging cycle.*

### How can I get maximum range or distance per charge?

Rarely do you have an ideal driving situation such as smooth, flat, hard terrain with no wind, hills, or curves. More often you are presented with hills, pavement cracks, uneven and loosely packed surfaces, curves, and wind. All of these factors will affect the distance or running time per battery charge. Below are a few suggestions for obtaining the maximum range per charge:

- Always charge the batteries fully prior to your trip.
- Plan your trip in advance to avoid inclines if possible.
- Limit baggage weight to essential items.
- Try to maintain an even speed and avoid stop-and-go driving.

### What type of batteries should I use?

We recommend deep-cycle batteries that are sealed and maintenance free. Both AGM and Gel-Cell are deep-cycle batteries that are similar in performance.



**WARNING! Corrosive chemicals contained in batteries. Use only AGM or Gel-Cell batteries to reduce the risk of leakage or explosive conditions.**

## VI. BATTERIES AND CHARGING

### **Why do my new batteries seem weak?**

Deep-cycle batteries employ a much different chemical technology than that used in car batteries, nickel-cadmium (nicads), or in other common battery types. Deep-cycle batteries are specifically designed to provide power, drain down their charge, and then accept a relatively quick recharge. AGM or Gel-Cell batteries should be charged as often as possible. They do not have a “memory” like nickel-cadmium batteries.

We work closely with our battery manufacturer to provide a battery that best suits your power chair’s specific demands. Fresh batteries arrive regularly at Pride and are promptly shipped with a full charge. During shipping, the batteries encounter temperature extremes that may influence initial performance. Heat robs the charge from the battery, and cold slows the power available and extends the time needed to recharge the battery (just as with a car battery).

It might take a few days for the temperature of the battery to stabilise and adjust to its new ambient temperature. More importantly, it will take a few “charging cycles” (a partial drain— then a full recharge) to establish the critical chemical balance that is essential to the battery’s peak performance and long life. It will be well worth it to take the time to break in your battery properly.

### **How can I ensure maximum battery life?**

A fully charged deep-cycle battery will provide reliable performance and extended battery life. Keep your power chair’s batteries fully charged whenever possible. Batteries that are regularly and deeply discharged, infrequently charged, or stored without a full charge may be permanently damaged, causing unreliable power chair operation and limited battery life.

### **How should I store my power chair and its batteries?**

If you do not use your power chair regularly, we recommend maintaining battery vitality by charging the batteries at least once per week.

If you do not plan on using your power chair for an extended period, fully charge the batteries prior to storage. Disconnect the battery harnesses and store the power chair in a warm, dry environment. Avoid temperature extremes, such as freezing and excessively hot conditions, and never attempt to charge a frozen battery. A cold or frozen battery should be warmed for several days prior to recharging.

### **What about public transportation?**

AGM and Gel-Cell batteries are designed for application in power chairs and other mobility vehicles, allowing safe transportation on aircraft, buses, and trains, as there is no danger of spillage or leakage. We suggest you contact the carrier’s ticket counter in advance to determine that carrier’s specific requirements.

### **What about shipping?**

If you wish to use a freight company to ship your power chair to your final destination, repack your power chair in the original shipping container and ship the batteries in separate boxes.

# VII. CARE AND MAINTENANCE

## CARE AND MAINTENANCE

Your Quantum 1121 is a sophisticated power chair. Like any motorised vehicle, it requires routine maintenance checks. You can perform some of these checks, but others require assistance from a Quantum Rehab Provider. Preventive maintenance is very important. If you follow the maintenance checks in this section as scheduled, you can help ensure that your power chair gives you years of trouble-free operation. If you have any doubt as to your power chair's care or operation, contact your Quantum Rehab Provider.



**WARNING! Do not service the power chair when the seat is occupied.**

Your power chair, like most electrical equipment, is susceptible to damage from the elements. Avoid damp areas of any kind.



**WARNING! Direct or prolonged exposure to water or dampness could cause the power chair to malfunction electronically and mechanically. Water can cause electrical components to corrode and the chair's frame to rust. Power chairs should be examined periodically for signs of corrosion caused by water exposure, bodily fluid exposure, or incontinence. Damaged components should be replaced or treated immediately.**

### Should your power chair come in contact with water:

1. Dry your power chair as thoroughly as possible with a towel.
2. Allow your power chair to sit in a warm, dry place for 12 hours to allow unseen water to evaporate.
3. Check the joystick operation and the brakes before using your power chair again.
4. If any inconsistencies are found, take your power chair to a Quantum Rehab Provider. Power chairs that are frequently exposed to sources of water, such as incontinence, should be inspected often for corrosion and electronic components may need to be replaced frequently.

### Temperature

- Some of the parts of your power chair are susceptible to extreme changes in temperature. Always keep your power chair between the temperatures of -8°C (18°F) and 50°C (122°F).
- In extremely cold temperatures the batteries may freeze. The specific temperature at which they freeze depends on a number of factors, such as battery charge, usage, and composition of the batteries (e.g., AGM or Gel-Cell).
- Temperatures above 50°C (122°F) may cause your power chair to operate at a reduced speed. This reduced speed is a safety feature built into the controller that helps prevent damage to the motor and other electrical components.

### General Guidelines

- Avoid knocking or bumping the controller, especially the joystick.
- Avoid prolonged exposure of your power chair to extreme conditions, such as heat, cold, or moisture.
- Keep the controller clean.
- Check all connectors on the electronics tray to ensure that they are all tight and secured properly.
- Make sure pneumatic tyres are inflated to the psi/bar/kPa air pressure rating indicated on the tyre.



**WARNING! Make sure your tyres are inflated to the psi/bar/kPa air pressure rating indicated on the tyre for pneumatic tyres. Do not underinflate or overinflate your tyres. Low pressure may result in loss of control, and overinflated tyres may burst. Overinflating tyres can cause them to explode.**

**WARNING! Do not use a high pressure hose to inflate your tyres.**

- Use a rubber conditioner on the tyre sidewalls to help preserve them.



**WARNING! Never use a rubber conditioner on the tread area of the tyres; doing so may make the tyres slippery and cause your power chair to skid.**

# VII. CARE AND MAINTENANCE

- All wheel bearings are prelubricated and sealed. They require no subsequent lubrication.
- The body shroud has been sprayed with a clear sealant coating. You can apply a light coat of car wax to help it retain its high-gloss appearance.
- Check all electrical connections. Make sure they are tight and are not corroded. Batteries must sit flat within the battery well, with the battery terminals facing inward, toward each other. Refer to the frame decal for the correct wiring layout.



**WARNING! Even though the power chair has passed the necessary testing requirements for ingress of liquids, you should keep electrical connections away from sources of dampness, including direct exposure to water or bodily fluids and incontinence. Check electrical components frequently for signs of corrosion and replace as necessary.**

## Daily Checks

- With the controller turned off, check the joystick. Make sure it is not bent or damaged and that it returns to the neutral position when you release it. Check the rubber boot around the base of the joystick for damage. Visually inspect the boot. Do not handle or try to repair it. See your Quantum Rehab Provider if there is a problem.
- Visually inspect the controller harness. Make sure that it is not frayed, cut, or has any wires exposed. See your Quantum Rehab Provider if there is a problem with any harnesses.
- Check for flat spots on solid tyres. Flat spots could adversely affect stability.
- Inspect the armrests for loose hardware, stress points, or damage. See your Quantum Rehab Provider if there is a problem.

## Weekly Checks

- Disconnect and inspect the controller from the electronics tray. Look for corrosion. Contact your Quantum Rehab Provider if necessary.
- Ensure that all parts of the controller system are securely fastened to your power chair. Do not overtighten any screws.
- Check for proper tyre inflation. If a tyre does not hold air, contact your Quantum Rehab Provider for replacement of the tube.
- Calibrate the joystick if a noticeable difference in performance is detected or if the joystick does not operate properly. To calibrate the joystick, power off the unit, place the joystick in the neutral position, and power the unit back on. If a problem still exists with your joystick's performance, contact your Quantum Rehab Provider.
- Check the brakes. This test should be carried out on a level surface with at least three feet of clearance around your power chair.

### To check the brakes:

1. Turn on the controller and turn down the speed level of your power chair. See your controller manual.
2. After one second, check the battery condition meter. Make sure that it remains on.
3. Slowly push the joystick forward until you hear the electric brakes click. Immediately release the joystick. You must be able to hear each electrical brake operating within a few seconds of joystick movement. Repeat this test three times, pushing the joystick rearward, then left, and then right.

## Monthly Checks

- Check that the anti-tip wheels do not rub the ground when you operate the power chair. Adjust them as necessary. See V. "Comfort Adjustments."
- Check for extreme wear on the anti-tip wheels. Replace them as necessary.
- Check for drive tyre wear. See a Quantum Rehab Provider for repair.
- Check the rear casters for wear. Replace them as necessary.
- Check the rear forks for damage or fluttering which indicates that they may need to be adjusted or have the bearings replaced. See a Quantum Rehab Provider for repair.
- Keep your power chair clean and free of foreign material, such as mud, dirt, hair, food, drink, etc.

# VII. CARE AND MAINTENANCE

## Yearly Checks

Take your power chair to a Quantum Rehab Provider for yearly maintenance, especially if you use your power chair on a daily basis. This helps ensure that your power chair is functioning properly and helps prevent future complications.

## Storage

Your power chair should be stored in a dry place, free from temperature extremes. When storing, disconnect the batteries from the power chair. See VI. "Batteries and Charging."



**WARNING! If you fail to store the unit properly, the frame can rust and the electronics can be damaged.**

Batteries that are regularly and deeply discharged, infrequently charged, stored in extreme temperatures, or stored without a full charge may be permanently damaged, causing unreliable performance and limited service life. It is recommended that you charge the batteries periodically throughout periods of prolonged storage to ensure proper performance.

You may wish to place several boards under the frame of your power chair to raise it off of the ground during periods of prolonged storage. This takes the weight off the tyres and reduces the possibility of flat spots developing on the areas of the tyres contacting the ground.

## Disposal of Your Power Chair

Your power chair must be disposed of according to applicable local and national statutory regulations. Contact your local waste disposal agency or Quantum Rehab Provider for information on proper disposal of power chair packaging, metal frame components, plastic components, electronics, and batteries.

## Cleaning Instructions

- Use a damp cloth and mild, non abrasive cleanser to clean the plastic metal parts of your power chair. Avoid using products that may scratch the surface of your power chair.
- If necessary, clean your product with an approved disinfectant. Make sure the disinfectant is safe for use on your product before application.

**WARNING! Follow all safety instructions for the proper use of the disinfectant and/or cleaning agent before applying it to your product. Failure to comply may result in skin irritation or premature deterioration of upholstery and/or power chair finishes.**



**WARNING! Never hose off your power chair or place it in direct contact with water. Your power chair has a painted, ABS plastic body shroud that allows it to be easily wiped clean with a damp cloth.**

**WARNING! Never use any chemicals to clean a vinyl seat, as they may cause the seat to become slippery or dry out and crack. Use soapy water and dry the seat thoroughly.**

## Wheel Replacement

If you have pneumatic tyres and you have a flat tyre, replace the tube. If your chair is equipped with a solid tyre insert, then you must replace the whole wheel assembly. Replacement tyres, tubes, and wheel assemblies are readily available through your Quantum Rehab Provider.



**WARNING! Be sure that the power to the controller is turned off and the power chair is not in freewheel mode before performing this procedure.**

**WARNING! When changing a tyre, remove only the centre lug nut and washer, then remove the tyre. If any further disassembly is required, deflate the tyre completely or it may explode.**



## VII. CARE AND MAINTENANCE

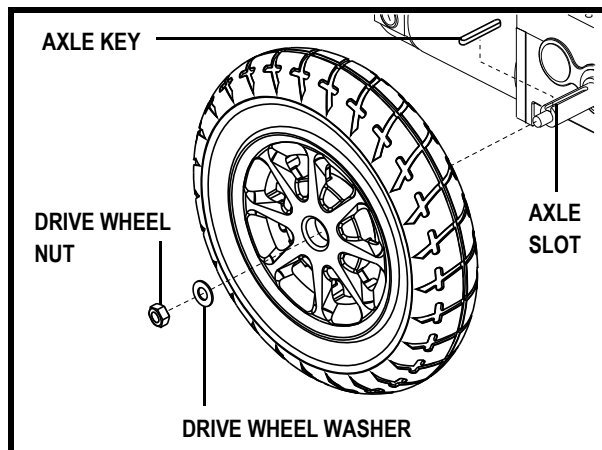

Figure 26. Drive Wheel

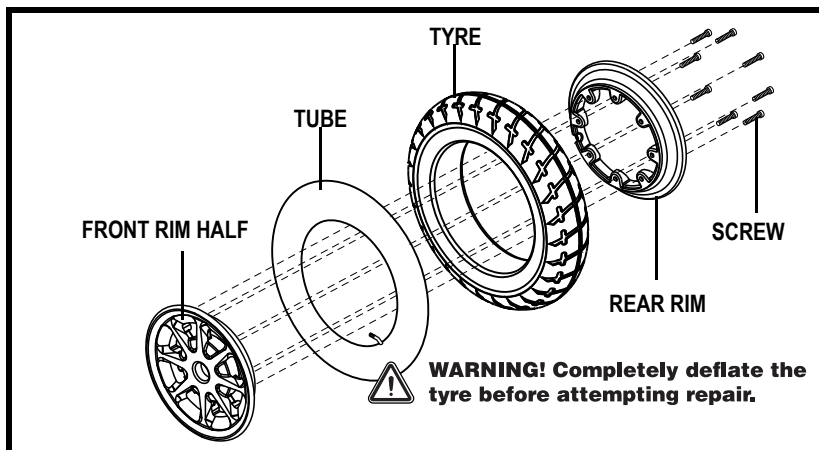

Figure 27. Drive Wheel Disassembled

Follow these easy steps for a quick and safe repair for both solid and pneumatic tyres:

1. Turn off the power to the controller.
2. Set the power chair up on blocks.
3. If you are changing a pneumatic tyre, completely deflate it before removing the wheel.
4. Remove the drive wheel nut and washer from the axle. See figure 26.
5. Pull the wheel off the axle.
6. Remove the screws from the rim assembly and separate the front and rear rim. See figure 27.
7. Remove the old tube from the pneumatic tyre and replace it with a new tube or replace the entire assembly if it is a solid tyre.
8. Reassemble the rims and reinstall the screws.
9. Slide the wheel back on to the axle. Make sure the key is in the slot.
10. Reinstall the drive wheel nut and washer onto the axle and tighten.
11. Inflate the pneumatic tyre to the psi/bar/kPa air pressure rating indicated on each tyre.
12. Remove the power chair from the blocks.

### Battery Replacement

A diagram is printed on a decal located on the power chair frame near the battery tray. See figure 28. See the specification table for correct battery specifications.



**MANDATORY! Battery posts, terminals, and related accessories contain lead and lead compounds. Wear goggles and gloves when handling batteries and wash hands after handling.**

**WARNING! The batteries in your power chair should only be serviced or replaced by a Quantum Rehab Provider or a qualified technician.**

**WARNING! Do not replace batteries when seat is occupied.**



**WARNING! Power chair batteries are heavy. See specifications table. If you are unable to lift that much weight, be sure to get help. Use proper lifting techniques and avoid lifting beyond your capacity.**

**WARNING! Do not mix old and new batteries. Always replace both batteries at the same time.**

To replace the batteries:

1. Turn off the power to the controller.
2. Make sure that the power chair is in drive mode. See III. "Your Power Chair."

## VII. CARE AND MAINTENANCE

3. Remove the ball detent pin that secures the foot platform to the frame. See figure 20.
4. Lift off the foot platform.
5. Locate the battery quick disconnects on the frame and disconnect both of them. See figure 29.
6. Remove the batteries from the power base.
7. Disconnect the wiring harness from each battery.
8. Reinstall the wiring harnesses on each battery. Make sure that you connect the red wire to the positive (+) battery terminal and the black wire to the negative (-) battery terminal. See figure 28.



**WARNING! Make sure you tighten the fasteners so that the connections are secure.**

9. Place the batteries back into the power base.
10. Connect the battery quick disconnects according to the battery wiring diagram label. See figure 28.
11. Reinstall the foot platform.

### When to See Your Quantum Rehab Provider for Service

The following symptoms could indicate a serious problem with your power chair. If necessary, contact your Quantum Rehab Provider. When calling, have the model number, serial number, nature of the problem, and the trouble code if available.

- Motor noise
- Frayed harnesses
- Cracked or broken connectors
- Uneven wear on any of the tyres
- Jerky motion
- Pulling to one side
- Bent or broken wheel assemblies
- Does not power up
- Powers up, but does not move

### Corrective Maintenance

If the battery condition meter does not light up when you turn on the power:

- Check the harness connections. Make sure they are tight.
- Check the circuit breaker. Reset it if necessary.
- Check the battery connections.

If the above conditions prove normal, you can load test the batteries with a battery load tester. These testers are available at automotive parts stores. Disconnect both batteries before load testing and follow the directions that come with the load tester. If either one of the batteries fails the load test, replace both of them. If your power chair still does not power up, contact your Quantum Rehab Provider.

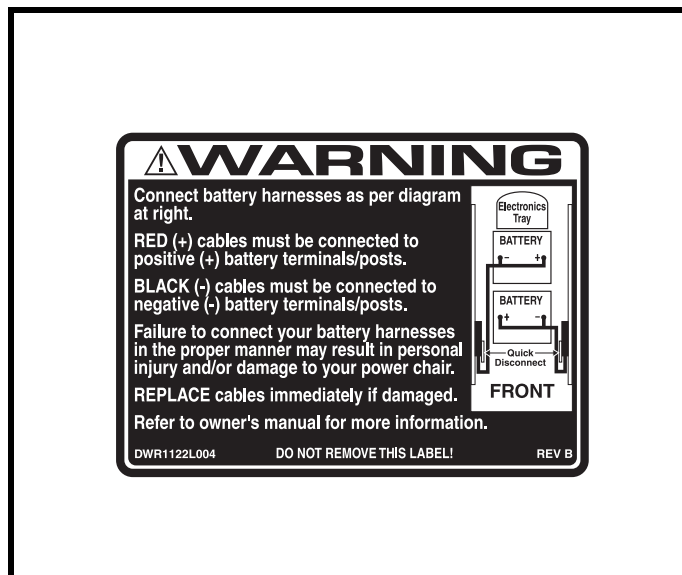

Figure 28. Battery Wiring Diagram Label

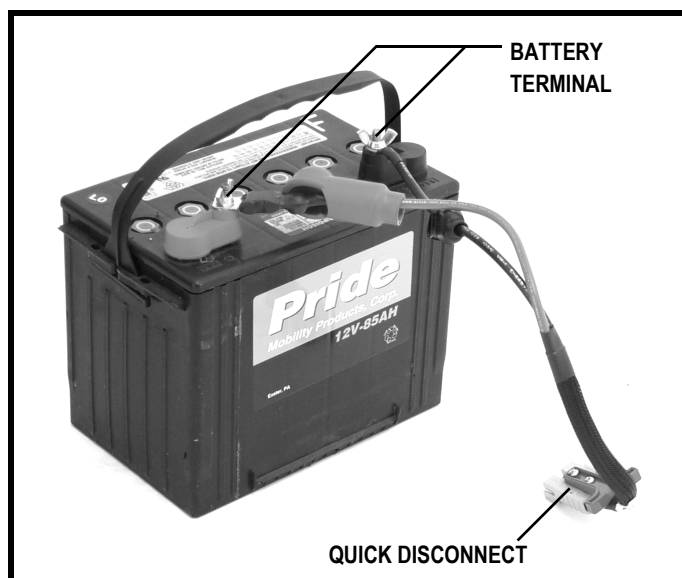

Figure 29. Battery and Harness

# VIII. WARRANTY

## **LIFETIME LIMITED WARRANTY**

Structural frame components, including: platform, fork, seat post, and frame welds.

## **TWO-YEAR LIMITED WARRANTY**

Drivetrain, including: differential, motor, and brake.

## **ONE-YEAR LIMITED WARRANTY**

Your Pride Power Chair is fully guaranteed for twelve (12) months from the date of purchase against faults arising due to defects in manufacture or materials. This warranty does not detract from, but is in addition to your legal rights.

All electronic parts, including controllers and battery chargers, have a one (1) year warranty. Servicing to the controller or battery charger must be carried out by your authorised Quantum Rehab Provider. Any attempt to open or dismantle these items renders the guarantee void on that item.

## **NOT COVERED UNDER WARRANTY**

This guarantee does not extend to those items which may need replacement due to normal wear and tear (tyres, belts, bulbs, upholstery, plastic shrouds, motor brushes, fuses, and batteries), or damage to the product caused by misuse or accident for which Pride or its agent cannot be held responsible. This warranty does not include labour or service calls.

## **BATTERIES**

Batteries are covered by a twelve (12) month warranty from the original manufacturer.

Gradual deterioration in performance due to being left in a discharged state, left in cold conditions for long periods of time, or worn out through heavy use is not covered.

## **SERVICE CHECKS AND WARRANTY SERVICE**

Warranty service can be performed by your authorised Quantum Rehab Provider. Please contact your authorised Quantum Rehab Provider for advice on the current cost affecting the service visit.

## **REPLACEMENT UNITS**

The availability of replacement units is subject to the discretion of the provider, not the manufacturer. For more information regarding replacement units, contact your authorised Quantum Rehab Provider.

# APPENDIX I - SPECIFICATIONS

SPECIFICATIONS	
Suspension:	Active-Trac
Drive Wheels:	35.5 cm (14 in.), pneumatic or solid, centre-mounted
Caster Wheels:	20.32 cm (8 in.), solid, rear articulating
Anti-tip Wheels:	15.25 cm (6 in.), solid, front mounted
Maximum Speed: <sup>1</sup>	Up to 8.04 km/h (5 mph)
Range: <sup>1,4</sup>	Variable up to 24.94 km (15.5 mi)
Brakes:	“Intelligent Braking” electronic regenerative, disc park brake
Ground Clearance: <sup>2</sup>	See figure 30.
Turning Radius: <sup>2</sup>	See figure 30.
Overall Size: <sup>2</sup>	Length: See figure 30. Width: See figure 30.
Drivetrain:	Two motor, mid-wheel
Batteries: <sup>3</sup>	Two 12-volt, deep-cycle NF-22 batteries
Battery Charger:	8-amp, off-board (standard) 5-amp, onboard/8-amp, off-board combination
Weight Capacity:	136 kg (300 lb) 72.57 kg (160 lb) with Synergy Manual Tilt
Component Weights:	Base: 63.5 kg (140 lb) Batteries: 17.23 kg (38 lb) each

<sup>1</sup> Varies with base model, user weight, terrain type, battery amp hour rating (Ah), battery charge, battery condition, motors, controller type, tyre type, and tyre condition. This specification can be subject to a variance of (+ or -) 10%.

<sup>2</sup> Due to manufacturing tolerances and continued product improvement, this specification can be subject to variance of (+ or -) 3%.

<sup>3</sup> AGM or Gel-Cell type required. See VI. “Batteries and Charging.”

<sup>4</sup> Tested in accordance with ASNI/RESNA, WC Vol 2, Section 4 & ISO 7176-4 standards. Results derived from theoretical calculation based on battery specifications and drive system performance. Test conducted at maximum weight capacity.

**NOTE: This product conforms to all applicable ANSI-RESNA testing requirements and ISO 7176 EN12184 standards. All specifications subject to change without notice.**

# APPENDIX I - SPECIFICATIONS

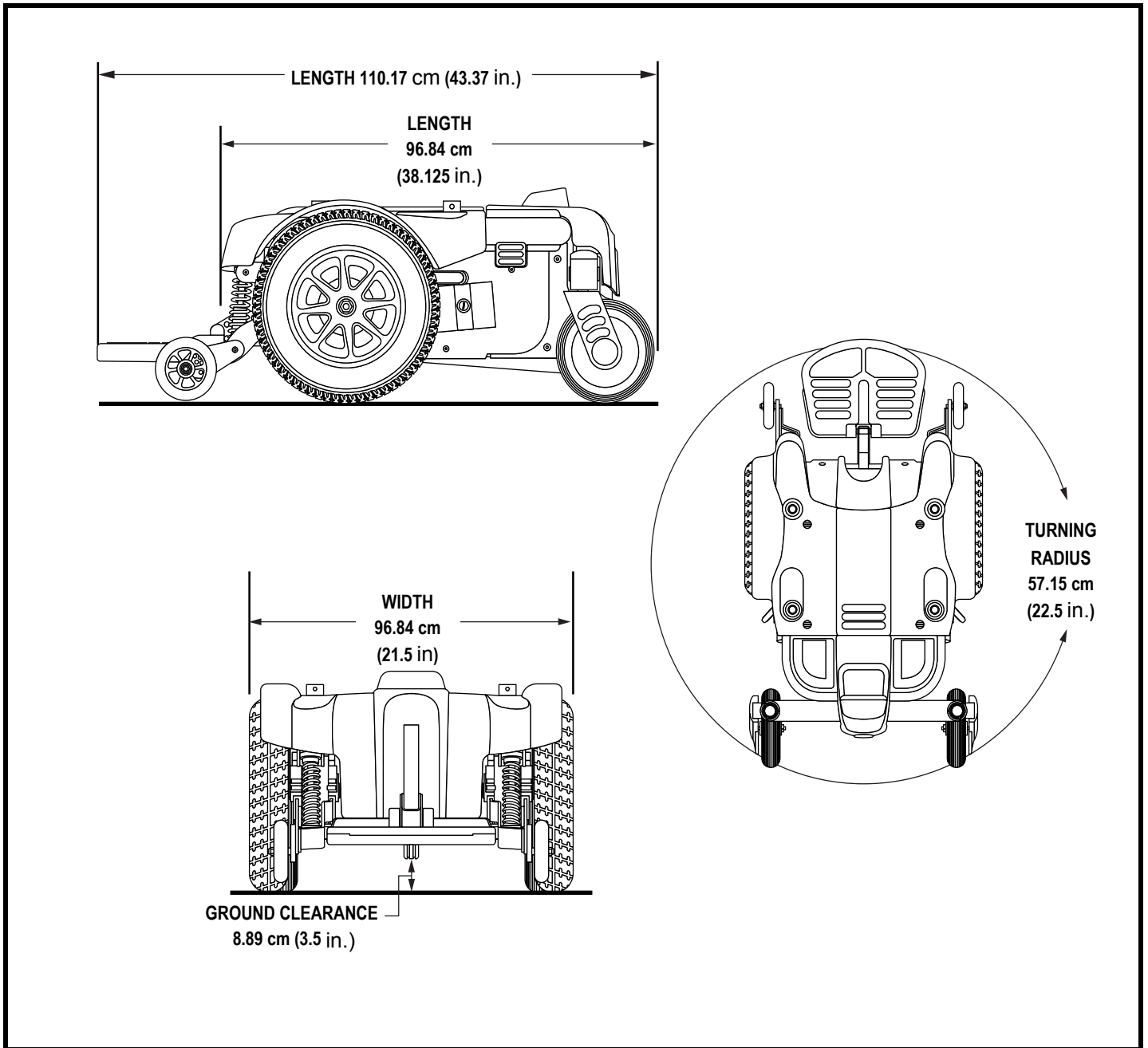

Figure 30. Quantum 1121 Series Specification

# NOTES

# Quality Control - Quantum 1121 Series

Inclusion of all Parts

\_\_\_\_\_  
Joystick Serial Number

\_\_\_\_\_  
Controller Serial Number

\_\_\_\_\_  
Left Motor Serial Number

\_\_\_\_\_  
Right Motor Serial Number

Fit and Finish

Performance



Pride keeps a more detailed report on file at the factory.

\_\_\_\_\_  
Date Inspected

\_\_\_\_\_  
Inspector

\* I N F M A N U 3 3 4 3 \*

\_\_\_\_\_  
Product Serial #