

Jazzy 1113

Owner's Manual

ATTENTION:
Please read the content
of your owner's manual
before operating your
power chair.



How a Power Chair Should Feel!™

Pride
Mobility Products Ltd.

Unit 106, Heyford Park Camp Road
Upper Heyford, Oxfordshire OX25 5HA

www.pridemobility.com

SAFETY GUIDELINES

Please read and follow all instructions in this owner's manual before attempting to operate your power chair for the first time. If there is anything in this manual you do not understand, or if you require additional assistance for set-up, contact your authorised Pride Dealer.

Using your Pride product safely depends upon your diligence in following the warnings, cautions, and instructions in this owner's manual. Using your Pride product safely also depends upon your own good judgement and/or common sense, as well as that of your Dealer, carer, and/or healthcare professional. Pride is not responsible for injuries and/or damage resulting from any person's failure to follow the warnings, cautions, and instructions in this owner's manual. Pride is not responsible for injuries and/or damage resulting from any person's failure to exercise good judgement and/or common sense.

The symbols below are used throughout this owner's manual to identify warnings and cautions. It is very important for you to read and understand them completely.



WARNING! Failure to heed the warnings in this owner's manual may result in personal injury.



CAUTION! Failure to heed the cautions in this owner's manual may result in damage to your power chair.

CONTENTS

I. INTRODUCTION	4
II. SAFETY	6
III. YOUR POWER CHAIR	13
IV. DISASSEMBLY	18
V. COMFORT ADJUSTMENTS	21
VI. ASSEMBLY	25
VII. OPERATION	28
VIII. BATTERIES AND CHARGING	40
IX. CARE AND MAINTENANCE	44
X. OPTIONAL ACCESSORIES	50
XI. WARRANTY	52

I . I N T R O D U C T I O N

INTRODUCTION

Welcome to Pride Mobility Products Ltd. (Pride). Congratulations on the purchase of your new Pride Power Chair. The Pride Power Chair design combines the most advanced state-of-the-art components with modern, attractive styling. We are certain that the design features and trouble-free operation of your new power chair will add convenience to your daily living.

At Pride, your safety is important to us. Please read and follow all of the instructions in this manual before you attempt to operate your power chair for the first time. These instructions were produced for your benefit. Your understanding of these instructions is essential for the safe operation of your new power chair.

Pride is not liable for damage to property or personal injury arising out of unsafe use of a power chair. Pride is also not liable for any property damage or personal injury arising out of the failure of any person and/or user to following the instructions and recommendations set forth in this manual or any other instructions or recommendations contained in other power chair related literature issued by Pride or contained on the power chair itself.

This owner's manual is compiled from the latest specifications and product information available at the time of publication. We reserve the right to make changes as they become necessary. Any changes to our products may cause slight variations between the illustrations and explanations in this manual and the product you have purchased.

If you experience any problems with your power chair that you are unable to solve, or if you do not feel capable of safely following any of the instructions and/or recommendations as contained in this manual, please contact your authorised Pride Dealer for assistance.

Once you understand how to operate and take care of your power chair, we are certain that it will give you years of trouble-free service and enjoyment.

Information Exchange

We want to hear your questions, comments, and suggestions about this manual. We would also like to hear about the safety and reliability of your new power chair, and about the service you received from your authorised Pride Dealer.

Please notify us of any change of address, so we can keep you apprised of important information about safety, new products, and new options that can increase your ability to use and enjoy your power chair. Please feel free to contact us at the address below:

Pride Mobility Products Ltd.
Unit 106, Heyford Park Camp Road
Upper Heyford, Oxfordshire OX25 5HA

I . I N T R O D U C T I O N

My Authorised Pride Dealer Is:

Name: _____

Address: _____

Phone Number: _____

Purchase Date: _____

NOTE: If you ever lose or misplace your product registration card or your copy of this manual, contact us and we will be glad to send you a new one immediately.

II. SAFETY

SAFETY



WARNING! Do not operate your new power chair for the first time without completely reading and understanding this owner's manual.

Your power chair is a state-of-the-art life-enhancement device designed to increase mobility. Pride provides an extensive variety of products to best fit the individual needs of the power chair user. Please be aware that the final selection and purchasing decision regarding the type of power chair to be used is the responsibility of the power chair user, who is capable of making such a decision, and his/her healthcare professional (i.e., medical doctor, physical therapist, etc.).

The contents of this manual are based on the expectation that a mobility device expert has properly fitted the power chair to the user and has assisted the prescribing healthcare professional and/or the authorised Pride Dealer in the instruction process for the use of the product.

There are certain situations, including some medical conditions, where the power chair user will need to practice operating the power chair in the presence of a trained attendant. A trained attendant can be defined as a family member or care professional specially trained in assisting a power chair user in various daily living activities.

As you begin using your power chair during daily activities, you will probably encounter situations in which you will need some practice. Simply take your time and you will soon be in full and confident control as you maneuver through doorways, on and off of lifts, up and down ramps, and over moderate terrain.

Below are some precautions, tips, and other safety considerations that will help the user become accustomed to operating the power chair safely.

Modifications

Pride has designed and engineered your power chair to provide maximum mobility and utility. A wide range of accessories is available from your authorised Pride Dealer to further customise your power chair to better suit your needs and/or preferences. However, under no circumstances should you modify, add, remove, or disable any feature, part, or function of your power chair.



WARNING! Do not modify your power chair in any way not authorised by Pride. Unauthorised modifications may result in personal injury and/or damage to your power chair.

Pre-Ride Safety Check

Get to know the feel of your power chair and its capabilities. Pride recommends that you perform a safety check before each use to make sure your power chair operates smoothly and safely. See IX. "Care and Maintenance."

Perform the following inspections prior to using your power chair:

- Check for proper tyre inflation. Maintain **2-2.4 bar (30-35 psi)** in each tyre (if equipped with pneumatic tyres).
- Check all electrical connections. Make sure they are tight and not corroded.
- Check all controller connections to the electronics tray. Make sure they are secured properly.
- Check the brakes. See IX. "Care and Maintenance."
- Check battery charge. See VIII. "Batteries and Charging."

II. SAFETY

NOTE: If you discover a problem, contact your authorised Pride Dealer for assistance.

Weight Limitations

Your power chair is rated for a maximum weight capacity. Please refer to the specifications table for this limit.



WARNING! Exceeding the weight capacity voids your warranty and may result in personal injury and/or damage to your power chair. Pride will not be held responsible for injuries and/or property damage resulting from failure to observe weight limitations.

WARNING! Do not carry passengers on your power chair. Carrying passengers on your power chair may result in personal injury and/or property damage.

Tyre Inflation

If your power chair is equipped with pneumatic tyres, you should check or have the air pressure checked at least once a week. Proper inflation pressures will prolong the life of your tyres and help ensure the smooth operation of your power chair.



WARNING! It is important that 2-2.4 bar (30-35 psi) tyre pressure be maintained in pneumatic tyres at all times. Do not underinflate or overinflate your tyres. Low pressure may result in loss of control, and overinflated tyres may burst. Failure to maintain 2-2.4 bar (30-35 psi) tyre pressure in pneumatic tyres at all times may result in tyre and/or wheel failure, causing serious personal injury and/or damage to your power chair.

WARNING! Inflate your power chair drive tyres from a regulated air source with an available pressure gauge. Inflating your tyres from an unregulated air source could overinflate them, resulting in a burst tyre and/or personal injury.

Incline Information

More and more buildings have ramps with specified degrees of inclination, designed for easy and safe access. Some ramps may have turning switchbacks (180-degree turns) that require you to have good cornering skills on your power chair.

- Proceed with extreme caution as you approach the downgrade of a ramp or other incline.
- Take wide swings with your power chair's front wheels around any tight corners. If you do that, the power chair's rear wheels will follow a wide arc, not cut the corner short, and not bump into or get hung up on any railing corners.
- When driving down a ramp, keep the power chair's speed adjustment set to the slowest speed setting to ensure a safely controlled descent. See VII. "Operation."
- Avoid sudden stops and starts.

When climbing an incline, try to keep your power chair moving. If you must stop, start up again slowly and then accelerate cautiously. When driving down an incline, set your power chair to the slowest setting and drive in the forward direction only. If your power chair starts to move down the incline faster than you anticipated or desired, allow it to come to a complete stop by releasing the joystick, then push the joystick forward slightly to ensure a safely controlled descent.

II. SAFETY

WARNING! When climbing an incline, do not zigzag or drive at an angle up the face of the incline. Drive your power chair straight up the incline. This greatly reduces the possibility of a tip or a fall. Always exercise extreme caution when negotiating an incline.

WARNING! You should not travel up or down a potentially hazardous incline (i.e., areas covered with snow, ice, cut grass, or wet leaves).



WARNING! When on any sort of an incline or decline, never place the power chair in freewheel mode while seated on it or standing next to it. Doing so may result in personal injury and/or damage to your power chair.

WARNING! Never travel down an incline rearwards. This may result in personal injury.

WARNING! Even though your power chair is capable of climbing slopes greater than those illustrated in figure 1, do not, under any circumstances, exceed the incline guidelines or any other specifications presented in this manual. Doing so could cause instability in your power chair, resulting in personal injury and/or damage to your power chair.

Pride recommends that the maximum slope of an incline you attempt to safely ascend or descend on your power chair does not exceed 8.7%. See figure 1.



WARNING! Any attempt to climb or descend a slope steeper than 8.7% may put your power chair in an unstable position and cause it to flip, resulting in personal injury.

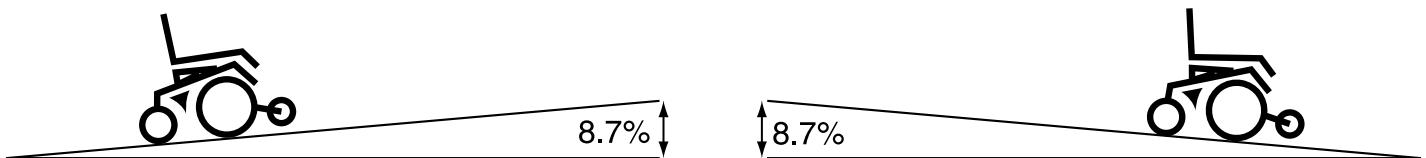

Figure 1. Maximum Safe Angle (Ascending and Descending)

Braking Information

Your power chair is equipped with two powerful brake systems:

1. Regenerative — uses electricity to rapidly slow the vehicle when the joystick returns to the center/stop position.
2. Disc Park Brake — activates mechanically after regenerative braking slows the vehicle to near stop, or when power is removed from the system for any reason.

Cornering Information

While your power chair is equipped with rear caster wheels in back and anti-tip wheels in front, excessively high cornering speeds can still create the possibility of tipping. Factors which affect the possibility of tipping include, but are not limited to: cornering speed, steering angle (how sharply you are turning), uneven road surfaces, inclined road surfaces, riding from an area of low traction to an area of high traction (such as passing from a grassy area to a paved area — especially at high speed while turning), and abrupt directional changes. High cornering speeds are not recommended. If you feel that you may tip over in a corner, reduce your speed and steering angle (i.e., lessen the sharpness of the turn) to prevent your power chair from tipping.

II. SAFETY



WARNING! When cornering sharply, reduce your speed. This greatly reduces the possibility of a tip or fall. To avoid personal injury and/or property damage, always exercise common sense when cornering.

Outdoor Driving Surfaces

Your power chair is designed to provide optimum stability under normal driving conditions—dry, level surfaces composed of concrete, blacktop, or tarmac. However, Pride recognises that there will be times when you will encounter other surface types. For this reason, your power chair is designed to perform admirably on packed soil, grass, and gravel. Feel free to use your power chair safely on lawns and in park areas.

- Reduce your power chair's speed when driving on uneven terrain and/or soft surfaces.
- Avoid tall grass that can entangle the running gear.
- Avoid loosely packed gravel and sand.
- If you feel unsure about a driving surface, avoid that surface.



WARNING! Exercise extreme caution when operating your power chair on pavements, bridleways, pedestrian areas, and roads. Obey the Code of practice for Class 3 vehicle users. Failure to heed this warning may result in serious injury and/or damage to your power chair.

NOTE: A copy of the Department of Transportation, Code of practice for Class 3 vehicle users, may be obtained by contacting your authorised Pride dealer.

Freewheel Mode

Your power chair is equipped with a manual freewheel lever to allow for manual maneuverability by a trained attendant. For more information about how to place your power chair into and out of freewheel mode, see III. "Your Power Chair."



WARNING! Do not use your power chair in freewheel mode without an attendant present. Personal injury may result.

WARNING! Do not attempt to personally place your power chair in freewheel mode while seated on it. Personal injury may result. Ask an attendant for assistance if necessary.

WARNING! Do not place your power chair in freewheel mode while on an incline. The chair could roll uncontrollably on its own, causing personal injury.

Stationary Obstacles (Steps, Kerbs, etc.)

Proceed with extreme caution when driving near raised surfaces, unprotected ledges and/or drop-offs (kerbs, porches, stairs, etc.). The correct method for approaching a kerb is illustrated in figure 1a.

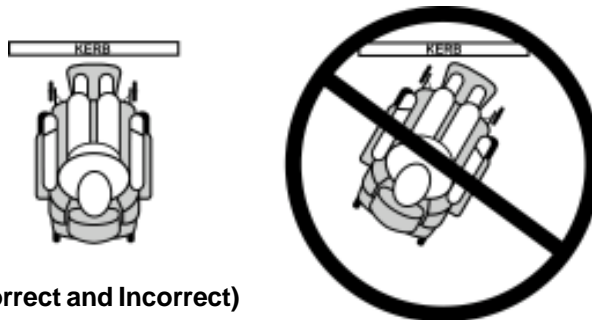

Figure 1a. Kerb Approach (Correct and Incorrect)

II. SAFETY



WARNING! Do not attempt to have your power chair climb or descend an obstacle that is higher than 2.54 cm (1 in.) unless you have the assistance of an attendant.

WARNING! Do not attempt to have your power chair proceed rearward down any step, kerb, or other obstacle. This may cause the power chair to tip and cause personal injury.

Public Streets and Roadways



WARNING! You should not operate your power chair on public streets and roadways. Be aware that it may be difficult for traffic to see you when you are seated on your power chair. Obey all local pedestrian traffic rules. Wait until your path is clear of traffic, and then proceed with extreme caution.

Stairs and Escalators

Power chairs are not designed to travel up or down stairs or escalators. Always use a lift.



WARNING! Never use your power chair to negotiate steps or escalators. You may cause injury to yourself and to others and/or damage your power chair.

Doors

- Determine if the door opens toward or away from you.
- Drive your power chair gently and slowly forward to push the door open. Or drive your power chair gently and slowly rearward to pull the door open.

Lifts

Modern lifts have a door edge safety mechanism that, when pushed, reopens the lift door(s).

- If you are in the doorway of an lift when the door(s) begin to close, push on the rubber door edge or allow the rubber door edge to contact the power chair and the door will reopen.
- Use care that handbags, packages, or power chair accessories do not become caught in lift doors.

EMI & RFI

Laboratory tests performed have shown that radio waves can cause unintended motion of electric mobility vehicles. Radio waves are a form of electromagnetic energy (EM). When EM adversely affects the operation of an electronic device, it is called Electromagnetic Interference (EMI) or Radio Frequency Interference (RFI).

Lift/Elevation Products

If you will be traveling with your power chair, you may find it necessary to use a lift/elevation product to aid in transportation. Pride recommends that you closely review the instructions, specifications, and safety information set forth by the manufacturer of the lift/elevation product before using that product.

Motor Vehicle Transport

Currently, there are no standards approved for tie-down systems in a moving vehicle of any type to transport a person while seated in a power chair.

II. SAFETY

Transfers

Transferring onto and off of your power chair requires a good sense of balance. Always have an attendant or healthcare professional present while learning to properly transfer yourself.

To eliminate the possibility of injury, Pride recommends that you or a trained attendant perform the following tasks before attempting a transfer:

- Turn the power off. See VII. “Operation.”
- Ensure your power chair is not in freewheel mode. See III. “Your Power Chair.”
- Turn both caster wheels toward the transfer destination to improve power chair stability during transfer.
- Make sure both armrests are flipped up or removed from your power chair.
- Flip the footrest up, or move the leg rests aside; this will help to keep your feet from getting caught on the footrest or the leg rests during the transfer.
- Reduce the distance between your power chair and the object you are transferring onto.

WARNING! Before transferring, position yourself as far back as possible in the power chair seat to prevent the power chair from tipping forward during transfer and causing injury.



WARNING! Avoid using your armrests for weight bearing purposes. Such use may cause the power chair to tip and cause personal injury.

WARNING! Avoid putting all of your weight on the footrest. Such use may cause the power chair to tip and cause personal injury.

Positioning Belts

Your authorised Pride Dealer, therapist(s), and other healthcare professionals are responsible for determining your requirement for a positioning belt in order to operate your power chair safely.

WARNING! If you require a positioning belt to safely operate your power chair, make sure it is fastened securely. Serious personal injury may result if you fall from the power chair.



WARNING! The positioning belt is not designed for use as a seat belt in a motor vehicle. Nor is your power chair suitable for use as a seat in any vehicle. Anyone traveling in a vehicle should be properly belted into seats approved by the vehicle manufacturer.

WARNING! Do not sit on your power chair while it is in a moving vehicle. Personal injury and/or property damage may result.

WARNING! Always be sure your power chair and its batteries are properly secured when it is being transported. Failure to do so may result in personal injury and/or damage to your power chair.

Inclement Weather Precautions



WARNING! Rain, snow, salt, mist/spray, or icy/slippery conditions could cause serious injury and/or damage to your power chair and the electronic system. Exposure to these weather elements should be avoided whenever possible. Use extreme care when driving at all times. Maintain and store your power chair in a dry and clean condition.

II. SAFETY

Reaching and Bending

Never reach, lean, or bend while driving your power chair. If it is absolutely necessary to reach, lean, or bend while seated on your power chair, it is important to maintain a stable center of gravity and keep the power chair from tipping. Pride recommends that the power chair user determine his/her personal limitations and practice bending and reaching in the presence of a qualified healthcare professional.



WARNING! Do not bend, lean, or reach for objects if you have to pick them up from the floor by reaching down between your knees. Movements such as these may change your center of gravity and the weight distribution of the power chair. This may cause your power chair to tip, possibly resulting in personal injury. Keep your hands away from the tyres when driving.

Batteries

In addition to following the warnings below, be sure to comply with all other battery handling information. For more information about your power chair's batteries, see VIII. "Batteries and Charging."



WARNING! Power chair batteries are heavy. See specifications table. If you are unable to lift that much weight, be sure to get help. Lifting beyond your capacity can result in personal injury.

WARNING! Battery posts, terminals, and related accessories contain lead and lead compounds. Wash hands after handling.

WARNING! Always protect the batteries from freezing and never charge a frozen battery. Charging a frozen battery may result in personal injury and/or damage to the battery.

Preventing Unintended Movement



WARNING! If you anticipate being seated in a stationary position for an extended period of time, turn off the power. This will prevent unexpected motion from inadvertent joystick contact. This will also eliminate the possibility of unintended chair movement from electromagnetic (EM) sources. Failure to do so may result in personal injury.

Prescription Drugs/Physical Limitations

Users must exercise care and common sense when operating a power chair. This includes awareness of safety issues when taking prescribed or over-the-counter drugs or when the user has specific physical limitations.



WARNING! Consult your physician if you are taking prescribed or over-the-counter medication or if you have certain physical limitations. Some medications and limitations may impair your ability to operate your power chair in a safe manner.

Alcohol

The power chair user must exercise care and common sense when operating his/her power chair. This includes awareness of safety issues while under the influence of alcohol.



WARNING! Do not operate your power chair while you are under the influence of alcohol, as this may impair your ability to operate your power chair in a safe manner.

Removable Parts



WARNING! Do not attempt to lift or move a power chair by any of its removable parts. Personal injury and/or damage to the power chair may result.

III. YOUR POWER CHAIR

Your Jazzy has two main assemblies: the seat and the power base. See figure 1b. There are a variety of seating options that are designed to accommodate most users. Typically, the seating system includes the armrests, the seatback, the seat base, and the controller. Your Jazzy seat may also have some optional accessories attached to it such as a basket, a cane and crutch holder, or a cup holder. See X. "Optional Accessories" in this manual.

The power base is the heart of the Jazzy 1113. The power base assembly includes two drive wheels, two anti-tip wheels, two rear caster wheels and harness connectors. See figures 1b, 2, and 3.

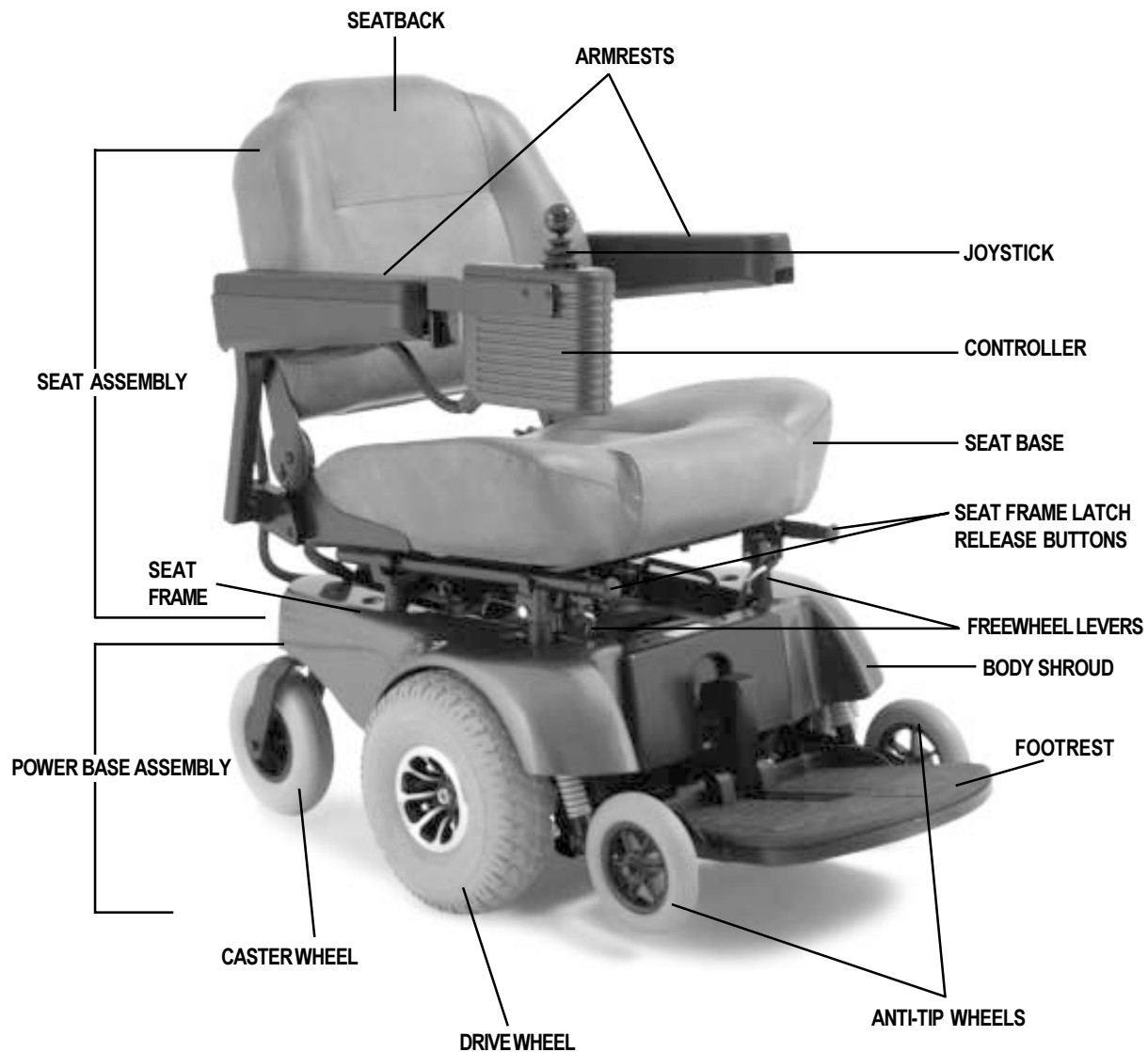
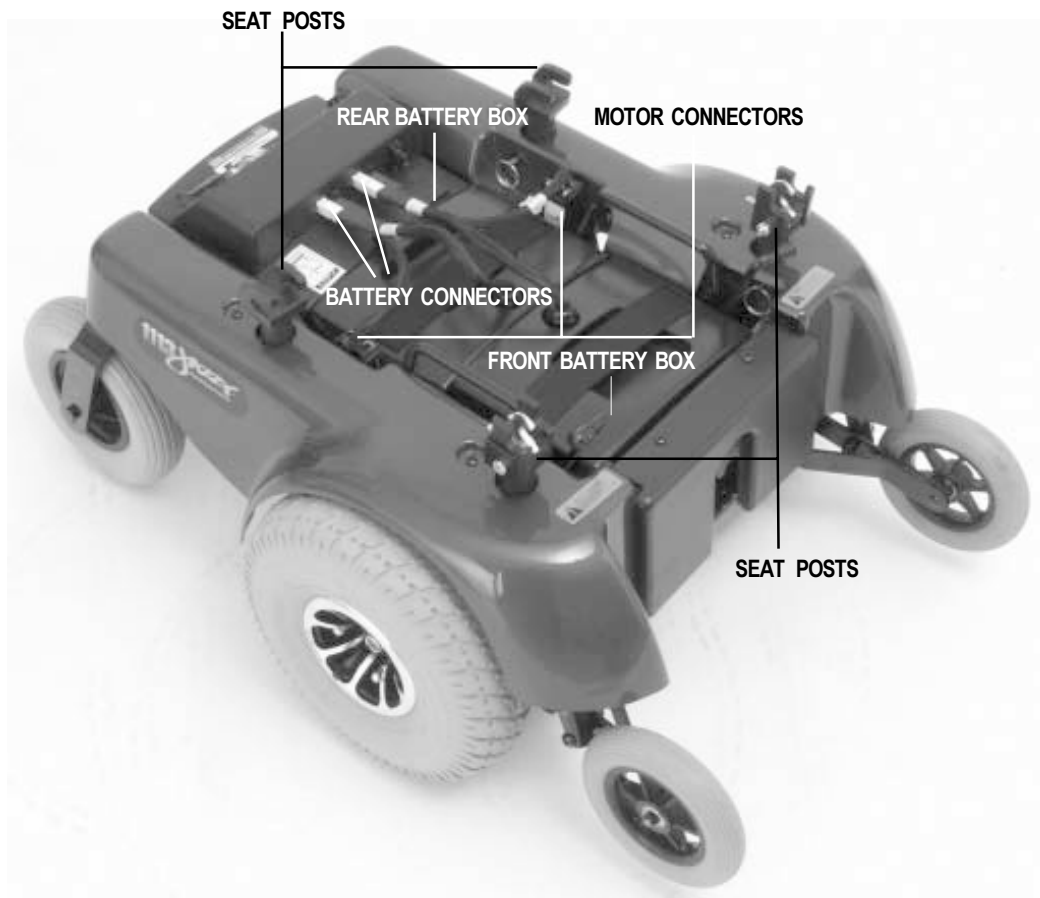
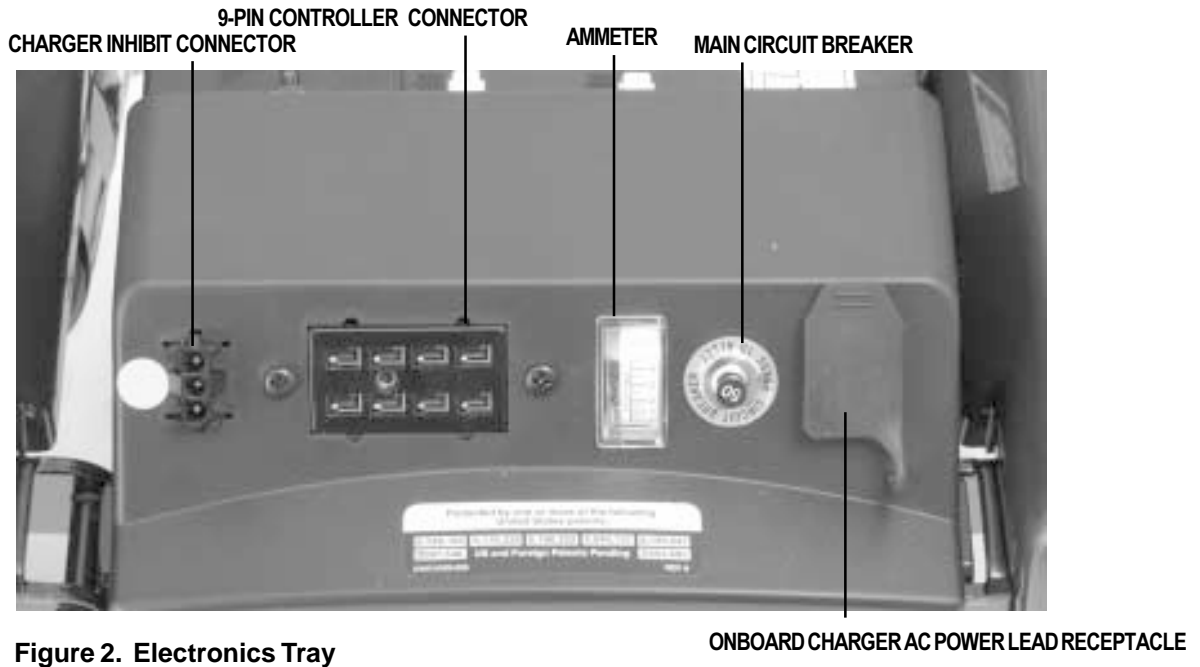

Figure 1b. The Jazzy 1113

III. YOUR POWER CHAIR

Specifications	
Suspension:	Limited suspension
Drive Wheels:	25 cm (10 in.), pneumatic, center mounted (solid tyres are optional)
Rear Caster Wheels:	20 cm (8 in.), solid, rear articulating
Anti-Tip Wheels:	15 cm (6 in.), solid, front mounted
Max. Speed:	Up to 6 km/h (4 mph)
Brakes:	“Intelligent Braking” electronic regenerative, disc park brake
Ground Clearance:	5 cm (2 in.)
Turning Radius:	43 cm (17 in.)
Overall Size:	Length: 82 cm (32 in.) Width: 59 cm (23 in.)
Seating Options:	Medium-Back (standard) Recliner High-Back with headrest
Drivetrain:	Two motor, mid-wheel
Batteries:	Two 12-volt, U-1 batteries
Range:	Up to 40 km (25 miles)
Battery Charger:	3-amp Onboard 3-amp Off-board (optional)
Electronics:	50-amp P&G VSI Controller 70 -amp Dynamic DX Controller 70-amp P&G Remote Plus Controller
Weight Capacity:	113 kg/18 stone/250 lbs.
Component Weights:	Seat: 15 kg (33 lbs.) Footrest: 4 kg (9 lbs.) Front battery and case: 11 kg (24.5 lbs.) (U-1) (Battery: 11 kg) Rear battery and case: 11 kg (24.5 lbs.) (U-1) (Battery: 11 kg) Battery well frame: 6 kg (13 lbs.) Front frame: 1 kg (2 lbs.) Right frame assembly: 15 kg (33 lbs.) Left frame assembly: 15 kg (33 lbs.)
Warranty:	Lifetime limited warranty on frame 2-year limited warranty on drivetrain 1-year limited warranty on electronics

III. YOUR POWER CHAIR



III. YOUR POWER CHAIR

The Power Base Assembly

The power base assembly consists of the right and left frame assemblies, the front and rear battery boxes, and the electronics tray. See figures 2, 3, and 4.

Ammeter: The ammeter displays the charger's current output in amps. See VIII. "Batteries and Charging."

Onboard Charger AC Power Lead Receptacle: This is where the AC power lead plugs into the onboard charger. The AC power lead plugs into a standard wall outlet.

Charger Fuse(s): The charger fuse protects the ammeter from overload during charging. The charger fuse is located under the electronics tray. A spare fuse is included.

Main Circuit Breaker: The main circuit breaker is a safety feature built into your power chair. When the batteries and the motors are heavily strained (e.g., from excessive loads), the main circuit breaker trips to prevent damage to the motors and the electronics. If the circuit breaker trips, allow your power chair to "rest" for approximately one minute. Then push in the circuit breaker reset button, turn on the controller, and continue normal operation. If the main circuit breaker trips repeatedly, contact your authorised Pride Dealer.

Controller Connector: This is where the controller connects to the battery, the motors, and the motor brakes. The VSI controller connector is shown.

Charger Inhibit Connector (VSI only): The VSI controller is equipped with a charger inhibit. The charger inhibit enables the onboard battery charger to disable the controller during charging. The charger inhibit connector is coded with coloured dots. The dots are positioned so that you can align the flat side of the male connector with the flat side of the female connector before making the connection.



CAUTION! Failure to properly align the connectors can result in damage to the controller, the onboard charger, and the connectors.

Manual Freewheel Levers

For your convenience, your power chair is equipped with two manual freewheel levers - one for each motor/brake assembly. See figures 3a and 3b. These levers allow you to disengage the drive motors and maneuver the chair manually.



WARNING! Do not use your power chair while the drive motors are disengaged unless you are in the presence of an attendant! Do not disengage the drive motors when your power chair is on an incline. The chair could roll down on its own, causing injury!

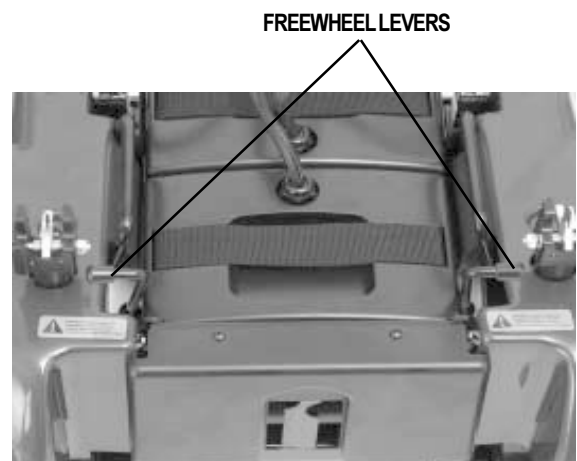

Figure 3a. Drive Motor Disengaged

III. YOUR POWER CHAIR

To engage or disengage the drive motors:

1. Turn the freewheel levers outward to disengage the drive motors.
2. Turn the freewheel levers toward the front of the Jazzy to engage the drive motors.



CAUTION! It is important to remember that when your power chair is in freewheel mode, the electronic braking system is disengaged.

If a lever is difficult to move in either direction, rock the Jazzy 1113 back and forth slightly. The lever should then move to the desired position.

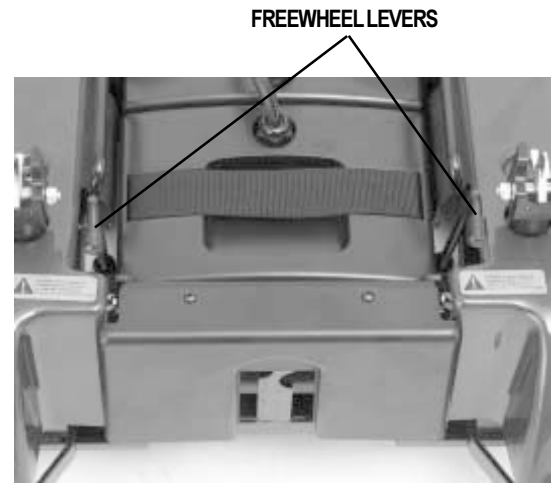

Figure 3b. Drive Motors Engaged

IV. DISASSEMBLY

The Jazzy 1113 disassembles into eight easily transportable component assemblies—with no tools required. See figure 4.



WARNING! Even though no tools are required to disassemble or assemble the Jazzy 1113, you should take care not to place your hands or fingers on the areas of the component assemblies where they may be pinched, as the assemblies “snap” together or “snap” apart.

WARNING! Some power chair components are heavy. You may need assistance to lift or carry them. Please refer to III. “Your Power Chair” for specific components weights.

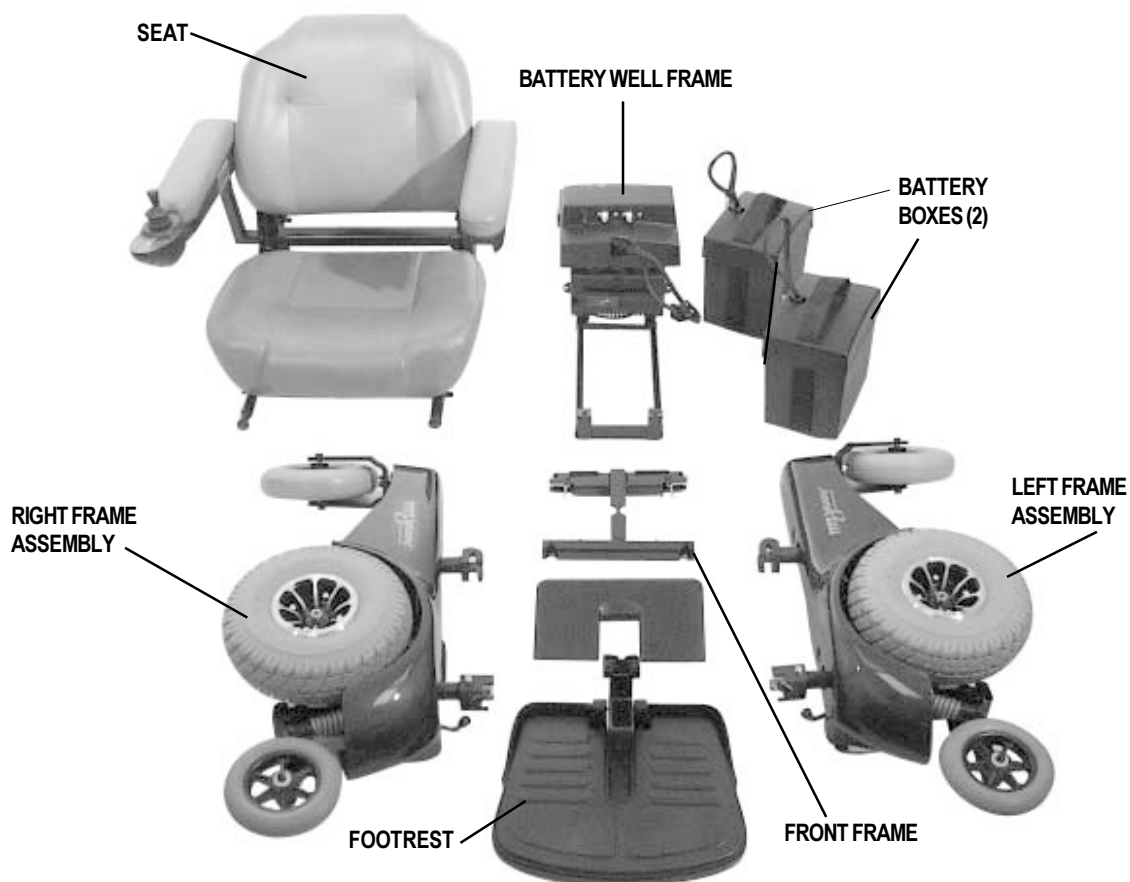

Figure 4. The Jazzy 1113 Component Assemblies

NOTE: During both the disassembly and the assembly of the Jazzy 1113, you may find it helpful to engage the Jazzy drive motors so that it does not roll while you are disassembling or assembling it. See III. “Your Power Chair.”

To disassemble the Jazzy 1113:

Position the Jazzy in a location where there is ample working room on all four sides of the Jazzy. We recommend 1 meter or more of clearance on all sides. There are eight component assemblies, some of which take up a great deal of space when disassembled from the chair. Also, make certain that the Jazzy is turned off.

IV. DISASSEMBLY

To remove the footrest:

Remove the footrest by sliding the mounting bracket up the vertical bar of the front frame until the tabs on the mounting bracket can be pulled forward through the matching slots in the front frame. See figure 5.

To disconnect the controller:

At the rear of the Jazzy, disconnect the controller (and charger inhibit if equipped) from the electronics tray located at the well frame. You may need to pull firmly and gently wiggle the connector to remove it from the socket. For the smaller connector, you must squeeze the connector latch release levers to disconnect the connector from the socket. See figure 6.

To remove the seat:

1. Disconnect the controller as previously described.
2. Push in the black spring-loaded seat frame latch release buttons (one on the front of each seat frame side tube). See figure 7.
3. While you are pushing both buttons or levers simultaneously, lift up on the front end of the seat frame.
4. Pull forward on the seat frame to release the locating pins from their slots in the rear seat post tower mounts. You may find it necessary to wiggle the frame gently from side to side to free the locating pins from their slots.



WARNING! Do not pick up the seat frame by the armrests. They are free to pivot, and you may lose control of the seat if they do so, resulting in personal injury or damage to the chair.

To remove the battery well frame:

1. Remove the seat as previously described.
2. Disconnect the battery case connectors (2) from the utility tray. See figure 8.
3. Next, disconnect and remove the battery cases (with the batteries in them) from the battery well frame.
4. Disconnect the left motor connector from its matching socket located on the left frame assembly. Squeeze the connector latch release levers to disconnect.
5. Disconnect the right motor connector from its matching socket located on the right frame assembly. Squeeze the connector latch release levers to disconnect.



Figure 5. Footrest Removal

DISCONNECT JOYSTICK CONTROLLER



Figure 6. Joystick Controller Harness

SEAT FRAME LATCH RELEASE BUTTONS

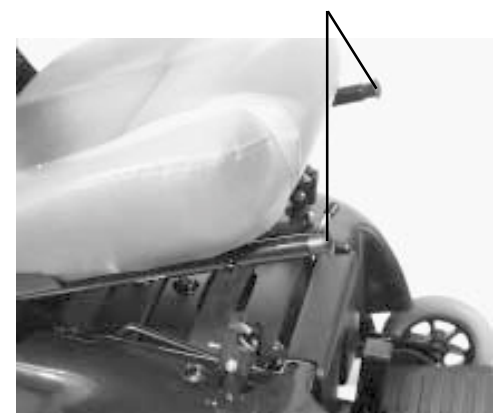

Figure 7. Remove the Seat

IV. DISASSEMBLY

6. Squeeze together the latch release levers that hang vertically down from the crossbar at the rear of the battery well frame. See figure 9. Lift up the rear end of the battery well frame. Pull it to the rear of the chair to release the front slots from the locating pins on the bottom bar of the front frame.

To disassemble the right frame assembly from the front frame:

1. Remove the battery well frame as previously described.
2. Stand behind the Jazzy and grasp the right frame assembly handle (located next to the front seat post tower) with your right hand.
3. Use your left hand and thumb to hold the front frame and press and hold (toward the center of the front frame) the silver-coloured latch release lever. See figure 10.
4. Push the right frame assembly outward (toward the right) with your right hand holding the right frame assembly handle.
5. Pull up with your left hand on the front frame until the latching mechanism releases.
6. Keep pulling upward with your left hand until the locating pin on the bottom of that side of the front frame releases from its slot in the right frame assembly.
7. Carefully let the right frame assembly tilt to a resting position.

To disassemble the left frame assembly from the front frame:

1. Remove the battery well frame as previously described.
2. Stand behind the Jazzy and grasp the left frame assembly handle (located next to the front seat post tower) with your left hand.
3. Use your right hand and thumb to hold the front frame and press and hold (toward the center of the front frame) the silver-coloured latch release lever. See figure 10.
4. Push the left frame assembly outward (toward the left) with your left hand holding the left frame assembly handle.
5. Pull up with your right hand on the front frame until the latching mechanism releases.
6. Keep pulling upward with your right hand until the locating pin on the bottom of that side of the front frame releases from its slot in the left frame assembly.
7. Carefully let the left frame assembly tilt to a resting position.



Figure 8. Disconnect Battery Cases



Figure 9. Front Frame



Figure 10. Front Frame

V. COMFORT ADJUSTMENTS

After you have become familiar with your Jazzy's operation, you may find the need to make adjustments to the Jazzy's seat. There are some adjustments you can make to increase your comfort such as seat height and angle, armrest height and angle, the footrest height and angles, and the joystick position.



WARNING! If your Jazzy 1113 was configured at your authorised Pride Dealer or service center, please consult your health care professional before changing seat position or making any other adjustment. Some of these adjustments may degrade your Jazzy's performance and safety by changing its center of gravity.

SEAT HEIGHT AND ANGLE

You can change the seat height by either raising or lowering the four seat towers.

To change the seat height:

1. Remove the seat. See IV. "Disassembly."
2. Remove the ball detent pin from each seat tower. See figure 11.

NOTE: Before you can remove the ball detent pin from each front seat tower, you must first remove the front battery box. See IV. "Disassembly."

3. Raise or lower each seat tower to the desired position.
4. Install the ball detent pin into each seat tower.
5. Reinstall the seat.

To change the seat angle:

You can change the seat angle by either raising or lowering only one set of seat towers (front or rear).

ARMREST WIDTH

To change the armrest width:

1. Locate the two knobs on the armrest receiver bracket. See figure 12.
2. Loosen the knobs and slide the armrests in or out to the desired width.
3. Tighten the knobs.

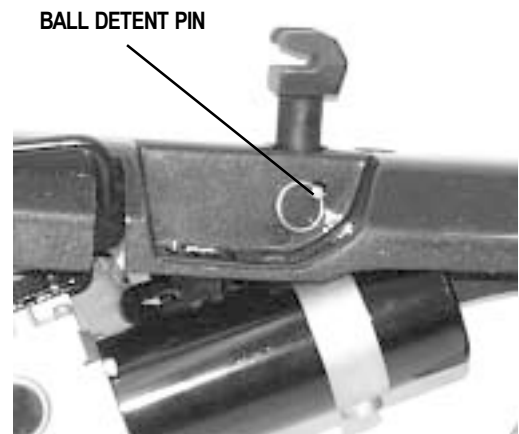

Figure 11. Seat Height Adjustment

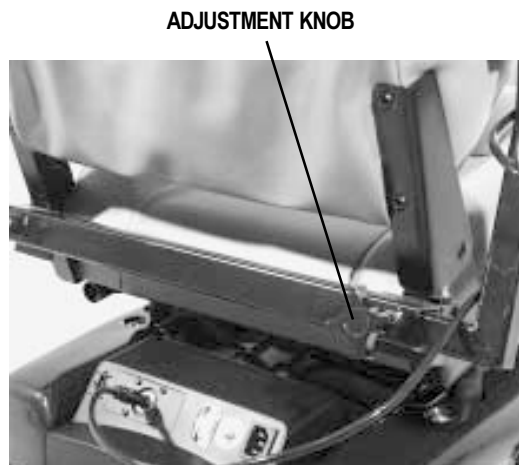

Figure 12. Armrest Width Adjustment

V. COMFORT ADJUSTMENTS

ARMREST ANGLE

You can increase or decrease the armrest angle to fit your specific needs. See figure 13.

To change the armrest angle:

1. Lift the armrest straight up so that it is perpendicular to the floor.
2. Use a 7/16-in. spanner to loosen the locking nut. See figure 13.
3. Use a 5/32-in. hex key to loosen the adjustment screw.
4. Turn the screw clockwise to lower the front of the armrest and anticlockwise to raise the front of the armrest.
5. Lock the adjustment screw into place by tightening the jam nut.

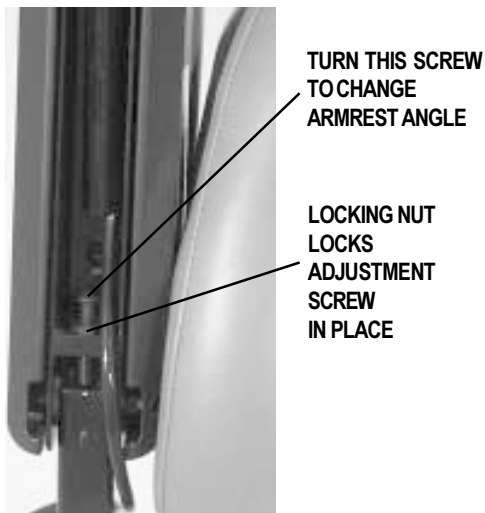

Figure 13. Armrest Angle Adjustment



Figure 14. Underside of Armrest

ARMREST HEIGHT (OPTIONAL)

Your Jazzy may be equipped with height-adjustable armrests.

To change the armrest height:

1. Remove the ball detent pin from the armrest.
2. Move the armrest up or down to the desired height.
3. Align the holes and reinsert the ball detent pin.

CONTROLLER EXTENSION

The controller can easily slide out away from the armrest, or in toward the armrest.

To extend the controller:

1. Use a 3/16-in. hex spanner to loosen the setscrew. See figure 14.
2. Slide the controller mounting bracket into or out of the armrest to the desired position.
3. Tighten the setscrew.

V. COMFORT ADJUSTMENTS

CONTROLLER POSITION

You can position the controller for either left-hand or right-hand use.

To change the controller position:

1. Disconnect the controller harness from the rear battery box. See figure 6.
2. Cut the wire tie that attaches the controller cable to the armrest.
3. Use a 3/16-in. hex key to loosen the setscrew. See figure 14.
4. Slide the controller mounting out of the armrest and place it in the other armrest.
5. Tighten the setscrew.
6. Connect the controller cable to the armrest with a wire tie. See figure 15.

FOOTREST HEIGHT

The footrest height is easily adjusted to one of six different heights, in 2.5 cm increments.

To raise or lower the footrest:

1. Remove the socket cap screw, 5/16-in. nut, and washers from the footrest. See figure 16.
2. Raise or lower the footrest to the desired height.
3. Install the socket cap screw, nut, and two washers into the footrest and tighten.

FOOTREST ANGLE

You can adjust the angle of the footrest with a 3/16-in. hex key. See figure 16.

To adjust the footrest angle:

1. Turn the setscrew clockwise to lower the front of the footrest.
2. Turn the setscrew anticlockwise to raise the front of the footrest.
3. Tighten the setscrew by turning it clockwise.

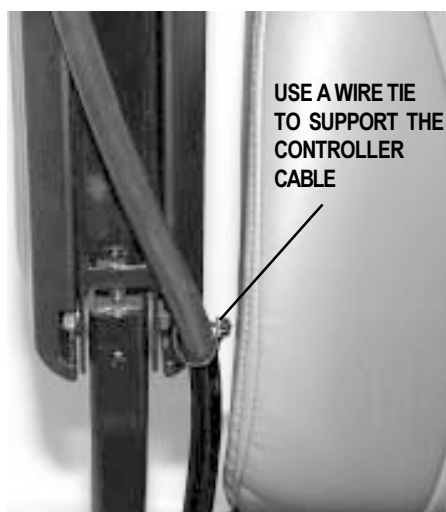

Figure 15. Wire Tie Location



Figure 16. Footrest Adjustment

V. COMFORT ADJUSTMENTS

ANTI-TIP WHEELS

The anti-tip wheels are an integral part of your power chair's mid-wheel design because they provide you with stability during deceleration. The anti-tip wheels are preset at the factory to a height of 2-cm, which is measured from the ground to the bottom of the wheel. This is the ideal setting for most power chair users. However, you may encounter situations where you may need to adjust the anti-tip wheels. For instance, if you drive your power chair on surfaces such as deep pile carpeting, you may notice that the anti-tip wheels have a tendency to drag on the carpet. In this case, you may need to raise the anti-tip wheels. If you drive your power chair primarily on smooth surfaces such as linoleum or tile, you may find that you tip forward more than is comfortable for you. (This may be more apparent for lighter users.) In this case, you may need to lower the anti-tip wheels.



WARNING! Consult your authorised Pride Dealer before attempting to change the anti-tip wheel height! Changing the anti-tip wheel height affects handling under deceleration!

WARNING! The higher you raise the anti-tip wheels, the more you increase your power chair's tendency to tilt forward when coming to a stop. You can compensate for this by having your authorised Pride Dealer make a small adjustment to the pre-programmed deceleration setting in the controller or by moving the seat assembly further to the rear of your power chair.

Anti-Tip Wheel Adjustment

You will need a 1/2-in. spanner and socket and a Phillips head screwdriver.

To adjust the anti-tip wheels:

1. Make sure that the manual freewheel levers are in the drive position.
2. Unplug the controller connectors from the electronics tray.
3. Remove the seat. See IV. "Disassembly."
4. Unplug the left and right motor connectors.
5. Unplug and remove both battery boxes.
6. Remove all four seat post ball detent pins (4) and remove the seat posts.
7. Remove both left and right shrouds by loosening and removing the four Phillips head screws. Two screws fasten each shroud section to the frame. These screws are located on the top of the shroud near the seat post holes.
8. Locate the anti-tip adjustment nut. See figure 17.
9. Use a 1/2-in. spanner to turn the adjustment nut. To lower the anti-tip wheels and soften the suspension, turn the adjustment nut anticlockwise. To raise the anti-tip wheels and stiffen the suspension, turn the adjustment nut clockwise. Make the same adjustment on both anti-tip wheels.
10. Reinstall the left and right shrouds.
11. Reinstall the four seat posts.
12. Reinstall both battery boxes.
13. Plug the left and right motor connectors back into their sockets.
14. Reinstall the seat.
15. Plug the controller connectors into the electronics tray.

ANTI-TIP ADJUSTMENT NUT



Figure 17. Anti-Tip Adjustment

VI. ASSEMBLY

ASSEMBLY

1. Place the three frame assemblies next to each other as shown in figure 18.
2. Stand behind the assemblies, grasp the front frame with your left hand, and fit the notch on the bottom bar of the front frame onto the locating pin on the lower section of the right frame assembly. (The frame is shown in figure 19.)
3. Pivot the front frame top bar toward the right frame assembly and, while holding the latch release lever, push the top bar of the front frame onto the locking mechanism until the two assemblies snap securely into place. Release the latch release lever to hold the two assemblies together.

NOTE: The front frame should be positioned with the two semicircular notches in the vertical bar facing forward.

4. Grasp the other frame assembly and lift the frame assembly into an upright position.
5. Tilt the front frame and the attached frame assembly (right side) so that the notch on the bottom bar of the front frame fits onto the locating pin on the bottom section of the other frame assembly (left side). You will also have to tilt the frame assembly (left side) slightly away from the front frame to make the parts fit together. See figure 20.
6. Pivot together the right frame assembly and the front frame, while holding the latch release lever, until the locking mechanism on the top bar of the front frame snaps securely to the left frame assembly. Release the latch release lever to hold the two assemblies together.



WARNING! Make certain that the front frame is snapped securely to both the right frame assembly and to the left frame assembly.



Figure 18. Frame Assemblies

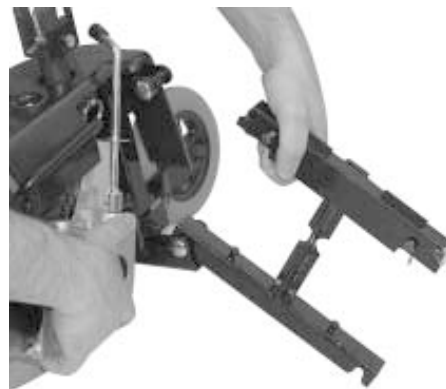

Figure 19. Front Frame Assembly

VI. ASSEMBLY

To install the battery well frame:

1. Face the rear of the chair and hold the battery well frame so that the “belly” of the well hangs downward.
2. Position the notches on the front of the battery well frame onto the locating pins on the bottom bar of the front frame. See figure 21.
3. Fit the notch on either side of the rear of the battery well frame onto the locating pin on the right frame assembly and onto the locating pin on the left frame assembly.
4. Make certain that the locking mechanisms snap securely into place.



Figure 20. Fitting the Frames

To install the battery cases:

1. Place the front battery case (with the battery inside) into the front end of the battery well frame.

NOTE: Make certain that the connectors are facing toward the center.

2. Place the rear battery case (with the battery inside) into the back end of the battery well frame.
3. Make certain that none of the wiring harnesses or cables are pinched between the battery or the motor controller box and the frame.
4. Connect the 4-conductor power cable connectors from the front and rear battery cases to the electronics tray. Push the connector firmly and fully into the socket. See figure 22.
5. Reconnect the left and right motor connectors to their sockets located on the left and right frame assemblies. Be certain to match the left connector to the left motor and the right connector to the right motor (the connectors are labeled left and right).

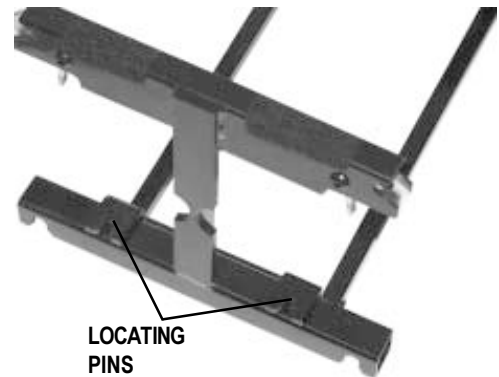

Figure 21. The Locating Pins

To install the seat:

1. Pick up the seat by the frame itself (not by the armrests) and slide the locating pins near the back of the frame into the matching slots on the left and rear seat post tower mounts.
2. Slide the pins to the back of the slots. It may be necessary to wiggle the seat slightly from side to side to seat the pins firmly at the back of the slots.
3. Push the front of the seat frame down until both the left and the right frame sides lock into the front seat post tower mounts. See figures 23 and 24.

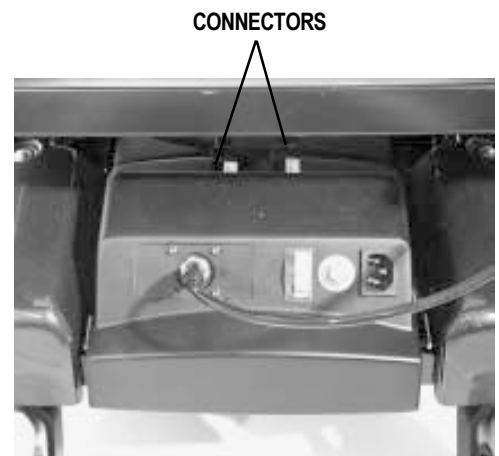

Figure 22. Electronics Tray

VI. ASSEMBLY

To mount the footrest:

1. Match the two tabs at the back of the footrest mounting bracket with the two semicircular notches in the vertical bar of the front frame.
2. Push the tabs through the matching notches.
3. Slide the footrest down into place. See figure 25.

To connect the controller:

1. Attach controller to the seat arm. See V. “Comfort Adjustments.”
2. Plug the controller harness connector into the electronics tray on the rear battery tray weldment as shown in figure 26.



CAUTION! Do not place the controller cable so that it can be pinched in the seat frame or the power base frame.



Figure 23. Seat Installation



Figure 24. Locking the Seat Frame



Figure 25. Mounting the Footrest



Figure 26. Connecting the Controller Harness

VII. OPERATION

VSI CONTROLLER

The electronic controller is what you use to operate your power chair. It takes the battery voltage and sends it to the appropriate system. The electronic controller enables you to move the power chair, as well as monitor battery charge, electronic controller functions, and the condition of your electrical system. Also, it may be used to control some optional systems such as power elevating seats and lights.

The VSI controller is an integral electronic controller. All of the electronics necessary to operate the power chair are contained in one module. See figure 27.

The VSI consists of:

1. joystick
2. keypad (see figure 28)
3. off-board charger/
programming socket
4. actuator connector
(optional)
5. controller connector
6. 3-pin charger inhibit
connector

Typically, the VSI is mounted to one of the armrests and is connected to the motors, batteries, and the onboard charger at the electronics tray.

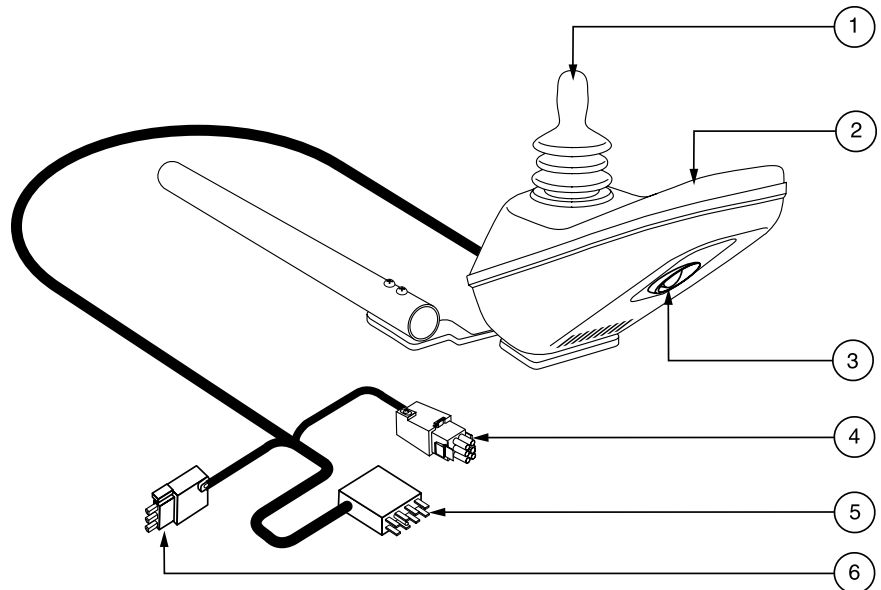

Figure 27. VSI Controller

Joystick

The joystick controls the direction and speed of your power chair. When you move the joystick from the neutral (center) position, the electromagnetic brakes release and allow your power chair to move. The further you push the joystick from its neutral position, the faster your power chair moves. When you release the joystick and allow it to return to the neutral position, you engage the electromagnetic brakes. This causes your power chair to decelerate and come to a complete stop.



WARNING! If your power chair begins to move in an unexpected manner, immediately release the joystick. Unless the joystick is damaged, this action should stop your power chair.

Keypad

The keypad is located in front of the joystick. It contains keys necessary to operate your Jazzy. See figure 28.

VII. OPERATION

On/Off Key

The on/off key turns the VSI on and off.



WARNING! Unless faced with an emergency situation, do not use the on/off key to stop the chair. This will cause the power chair to stop abruptly.

WARNING! Always turn the power off when you are stationary to prevent unexpected movement.

Battery Condition Meter

The battery condition meter is located in front of the joystick. See figure 28. This is a 10-segment illuminated display that indicates that the VSI is turned on and also gives the battery status, the VSI status, and the electrical system status.

- **Red, yellow, and green lights lit:** Battery charged; VSI and electrical system OK.
- **Red and yellow lights lit:** Charge battery if possible; VSI and electrical system OK.
- **Red lights only lit or slow flash:** Charge battery as soon as possible; VSI and electrical system OK.
- **Rapid flash of lights:** Indicates a fault in the VSI or the electrical system. Refer to “Trouble Codes.”
- **Ripple up and down of lights:** The joystick was not in the neutral position when the controller was turned on. If you get “ripple up and down of lights”, turn off the controller, allow the joystick to return to the neutral position, then turn on the controller.

NOTE: If you still get “ripple up and down of lights”, contact your authorised Pride Dealer.

NOTE: When the batteries approach a discharged state, the first red light will begin to slowly flash, reminding you the batteries need to be charged immediately!

Speed/Profile Keys

There are two keys that control either the speed or the profile. See figure 28. This depends on how your VSI was programmed. Press the speed/profile increase key to increase the speed or change the profile. Press the speed/profile decrease key to decrease the speed or change the profile. The speed/profile setting is displayed on the maximum speed/profile indicator. If your power chair was programmed with a drive profile, contact your authorised Pride Dealer for more information.

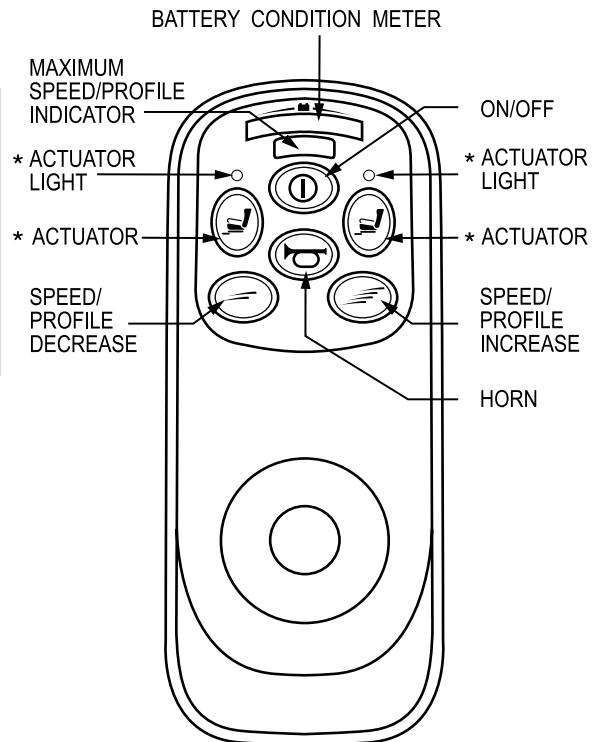

*For optional equipment on some models.

Figure 28. VSI Controller Keypad

VII. OPERATION

NOTE: We recommend that the first few times you operate your power chair, you set the speed to the slowest setting until you become familiar with your new power chair.

Actuator Key and Actuator Lights (for optional equipment)

Actuator keys and actuator lights are used for optional equipment such as power elevating seats or power elevating leg rests. For specific operation of the actuator keys and actuator lights, contact your authorised Pride Dealer.

Horn Key

The horn key activates the horn.

Off-board Charger/Programming Socket

You may use an off-board charger to charge the power chair batteries through the 3-pin socket located on the front of the VSI. See figure 27. If you use an off-board charger, the charger current should not exceed 12 amps. Contact your authorised Pride Dealer for more information.



CAUTION! Only chargers with Neutrik NC3MX plugs should be connected to the off-board charger/programming socket. See your authorised Pride Dealer for more information.

NOTE: The socket may also be used for reprogramming the VSI. Contact your authorised Pride Dealer for more information.

Controller Connector

This connects the VSI to the power chair's batteries, motors, and motor brakes.

3-pin Charger Inhibit Connector

This connects the VSI to the onboard battery charger. This connection provides an inhibit that disables the VSI when the battery charger is on. The charger inhibit connector is coded with coloured dots. The dots are positioned so that you align the flat side of the male connector with the flat side of the female connector before making the connection.



CAUTION! Failure to properly align the connectors can result in damage to the VSI, the charger, and the connectors.

Thermal Rollback

The VSI controller is equipped with a thermal rollback circuit. The circuit monitors the temperature of the controller, which roughly translates to motor temperature. In the event that the VSI controller becomes excessively hot (above 60° C/140° F), motor current (amperage) is reduced. For every degree above 60° C/140° F, the motor current limit is reduced by .55 amps until the VSI controller reaches 70° C/158° F, at which time the current output is reduced to zero. This reduces your power chair's "power," which could also reduce your power chair's speed, and allows the electrical components and motors to cool down. When the temperature returns to a safe level, your power chair resumes its normal operation.

VII. OPERATION

Troubleshooting

The VSI controller is designed with the user's safety as the prime consideration. It incorporates many sophisticated self-test features which search for potential problems at a rate of 100 times per second. If the VSI detects a problem either in its own circuits or in the power chair's electrical system, it may stop the power chair, depending on the severity of the problem. The VSI is designed to maximise the user's safety under all normal conditions. The table below identifies the individual error codes. Error codes are displayed as a rapid flashing of the lights on the battery condition meter. If you get one of these error codes, contact your authorised Pride Dealer.

Trouble Codes

FLASHING LIGHTS	DIAGNOSIS AND SOLUTION
1	The battery needs charging or there is a bad connection to the battery. Check the connections to the battery. If the connections are good, try charging the battery.
2	The left motor has a bad connection. Check the left motor connection.
3	The left motor has a short circuit to a battery connection. Contact your authorised Pride Dealer.
4	The right motor has a bad connection. Check the right motor connection.
5	The right motor has a short circuit to a battery connection. Contact your authorised Pride Dealer.
6	The power chair is being inhibited by the battery charger. Unplug the battery charger.
7	A joystick fault is indicated. Make sure that the joystick is in the neutral (center) position before turning on the controller.
8	A controller system fault is indicated. Make sure that all connections are secure.
9	The parking brakes have a bad connection. Check the parking brake and motor connections. Make sure the controller connections are secure.
10	An excessive voltage has been applied to the controller. This is usually caused by a poor battery connection. Check the battery connections.

VII. OPERATION

REMOTE PLUS CONTROLLER

The electronic controller is what you use to operate your power chair. It takes the battery voltage and sends it to the appropriate system. The electronic controller also enables you to monitor battery charge, electronic controller functions, and the condition of your electrical system. Also, it may be used to control some optional systems such as power elevating seats and lights.

The Remote Plus is a modular electronic control system. The electronics necessary to operate the power chair are contained in several modules located on different parts of your power chair.

The Remote Plus system consists of the following components:

- master remote
- communications cable(s)
- power module
- motor wiring harnesses
- battery wiring harnesses
- actuator lighting module (for optional equipment)

The master remote is located typically on the end of an armrest. The other components are located inside the power base.

Remote Plus Master Remote

The Remote Plus master remote consists of the following (see figure 29):

1. joystick
2. keypad
3. controller communications cable
4. off-board charger/programming socket

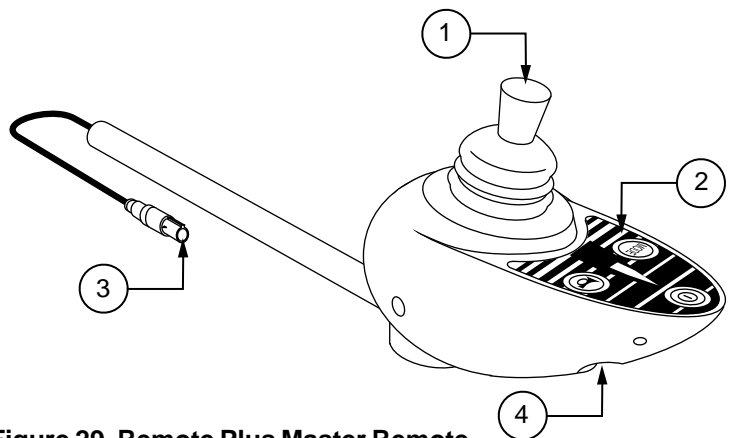

Figure 29. Remote Plus Master Remote

Joystick

The joystick controls the direction and speed of your power chair. When you move the joystick from the neutral (center) position, the electromagnetic brakes release and allow your power chair to move. The further you push the joystick from its neutral position, the faster your power chair moves. When you release the joystick and allow it to return to the neutral position, you engage the electromagnetic brakes. This causes your power chair to decelerate and come to a complete stop.



WARNING! If your power chair begins to move in an unexpected manner, immediately release the joystick. Unless the joystick is damaged, this action should stop your power chair.

Keypad

The keypad is located directly in front of the joystick. See figure 30. It contains keys that you will use to control your power chair.

VII. OPERATION

On/Off Key

The on/off keys turns the system power on and off.



WARNING! Unless faced with an emergency situation, do not use the on/off key to stop the chair. This will cause the power chair to stop abruptly.

WARNING! Always turn the power off when you are stationary to prevent unexpected movement.

Mode Key

Press the key to change speed setting or to activate the power accessories. See “Speed Settings” or “Power Accessories.”

Speed Setting Indicator

Indicates the selected speed setting.

Power Accessory Indicator

Indicates the selected power accessory. This is for optional accessories only.

Horn Key

The horn key activates the horn.

Right/Left Turn Indicator Keys

The right/left indicator keys toggle either the left or right turn indicators. Press once to turn on and press again to turn off. You can also turn off the selected indicator by pressing the opposite indicator key or the hazard key.

Light Key

The light key turns the headlights/taillights on and off independent of other indicators.

Hazard Key

The hazard key toggles both indicators at the same time. You can only cancel this by pressing the hazard key again.

Battery Condition Meter

The battery condition meter is located in front of the joystick. This is a 10-segment illuminated display that indicates that the Remote Plus is turned on and also gives the status of the battery, the controller, and the power chair electrical system.

- **Red, yellow, and green lights lit:** Battery charged; controller and electrical system OK.
- **Red and yellow lights lit:** Charge battery if possible; controller and electrical system OK.
- **Red lights only lit or slow flash:** Charge battery as soon as possible; controller and electrical system OK.
- **Rapid flash of lights:** Indicates a fault in the controller or the electrical system.
- **Ripple up and down of lights:** The joystick was not in the center position when the controller was turned on. If you get “ripple up and down of lights”, turn off the controller, allow the joystick to return to the center position, then turn on the controller.

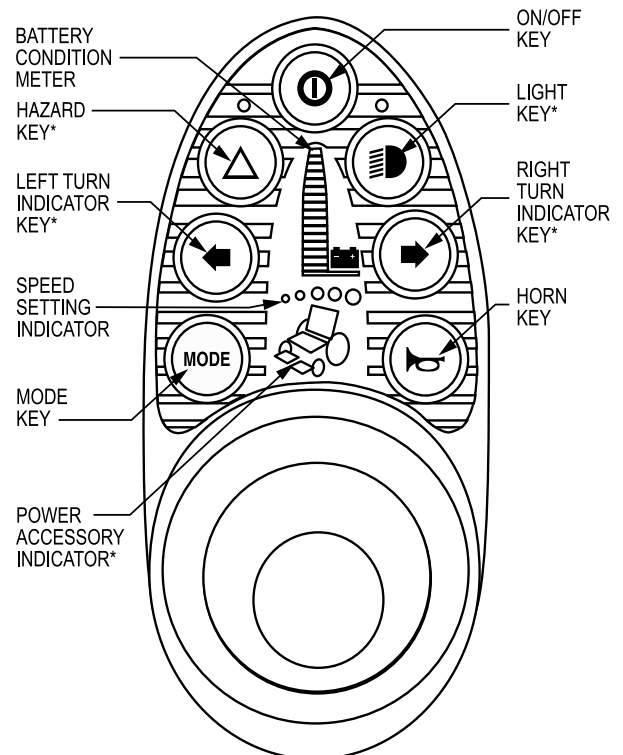

*These are optional accessories. Please contact your authorised Pride provider for more information.

Figure 30. Remote Plus Keypad

VII. OPERATION

NOTE: If you still get “ripple up and down of lights”, contact your authorised Pride Dealer.

NOTE: When the batteries approach a discharged state, the first red light will begin to slowly flash, reminding you the batteries need to be charged immediately!

Speed Settings

The Remote Plus speed settings range from 1 to 5. Typically, the slowest speed setting is 1 and the fastest speed setting is 5. The settings are indicated by the number of lights that are lit.

NOTE: The speed settings are preset at the factory. If your authorised Pride Dealer changes the order of these settings, please make note of these changes. Contact your authorised Pride Dealer for more information.

To select a speed setting:

1. Press the on/off key to power on the remote.
2. Press the mode key once.
3. To increase chair speed, push the joystick to the right. Each time you push the joystick, you will increase the speed setting.
4. To decrease chair speed, push the joystick to the left. Each time you push the joystick, you decrease the speed setting.
5. Once you select the desired speed setting, press the mode key once to keep the setting or push the joystick in the forward or reverse direction. The chair will resume operation at the selected speed.

NOTE: We recommend that the first few times you operate your power chair, you have your speed on the slowest setting until you become familiar with your new power chair.

Power Accessories

If your power chair is equipped with power accessories such as a power seat or power elevating leg rests, you can operate them through the remote keypad. Contact your authorised Pride Dealer for information on how to operate these accessories.

Off-board Charger/Programming Socket

You may use an off-board charger to charge the power chair batteries through the 3-pin socket located on the front of the controller. See figure 29. The socket may also be used for reprogramming the controller by using a Penny & Giles Programmer, should this be necessary. If you use an off-board charger, the charger current should not exceed 12 amps. Contact your authorised Pride Dealer for more information.



CAUTION! Only chargers with Neutrik NC3MX plugs should be connected to the off-board charger/programming socket. See your authorised Pride Dealer for more information.

Controller Communications Cable

The controller communications cable provides the joystick module with a connection to the power module at the back of the power base. See figure 29.

VII. OPERATION

Power Module

Typically, the power module is mounted to the power base. The power module provides a power interface for the joystick module. It routes the battery power to the motors and other powered accessories such as lights and power seats.

Actuator Lighting Module (Not Shown)

The actuator lighting module is also located on the power base. The actuator lighting module provides a control and power interface between the power module, the lights, and/or the power seat actuator.

Sleep Mode

Your Remote Plus controller has a sleep mode feature. Sleep mode is a built-in circuit that automatically shuts off the main power if the joystick is not moved in any direction for approximately five minutes. The battery condition meter lights on the keypad indicate sleep mode by blinking once every five seconds. To restore power and continue, push the on/off key twice.

Thermal Rollback

The Remote Plus is equipped with a thermal rollback circuit. This circuit monitors the temperature of the motors, power module, and remote. In the event that any of them become excessively hot (above 50° C /122° F), motor voltage is reduced. For every degree above 50° C /122° F, the voltage is reduced by 5 volts. This reduces your power chair's speed and allows the electrical components to cool down. When the temperature returns to a safe level, your power chair resumes its normal speed.

Trouble Codes

In addition to indicating the current state of battery charge, the battery condition meter can also indicate possible problems with your power chair. The battery condition meter has ten lights. The lights provide information by the number of lights that are flashing. If any of the meter lights are flashing rapidly, the controller may be indicating a fault. For instance, if the first light is flashing rapidly, the battery voltage is nearly depleted. The following is a list of the possible errors signified by the rapidly flashing meter. When you get a trouble code, contact your authorised Pride Dealer.

FLASHING LIGHTS	DIAGNOSIS	SOLUTION
10	High Battery Voltage	Check batteries.
9	Solenoid Brake Fault	Check motor/brake wiring.
8	Possible Controller Fault	See authorised Pride Dealer.
7	Possible Joystick Fault	See authorised Pride Dealer.
6	Inhibit Active Unplug Charger.	Check connections.
5	Right Motor Wiring Fault	Check right motor wiring.
4	Right Motor Disconnected	Check right motor wiring.
3	Left Motor Wiring Fault	Check left motor wiring.
2	Left Motor Disconnected	Check left motor wiring.
1	Low Battery Voltage	Check batteries/battery wiring.

VII. OPERATION

DX CONTROLLER

The Dynamic DX electronic control system is a modular system. The electronics necessary to operate the power chair are contained in several modules located on different parts of your power chair.

The Dynamic DX system consists of the following components:

- master remote (Europa)
- communications cable(s)
- power module
- motor wiring harnesses
- battery wiring harnesses
- actuator lighting module (for optional systems)

The master remote is located typically on the end of an armrest. The other components are located inside the power base.

Europa Master Remote

The Europa master remote consists of the following (see figure 31):

1. joystick
2. keypad
3. controller communications connector
4. off-board charger/programming socket

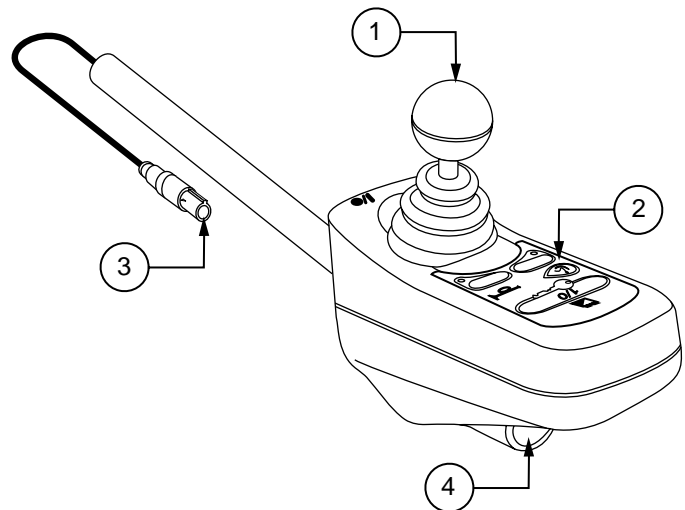

Figure 31. Europa Master Remote

Joystick

The joystick controls the direction and speed of the power chair. When you move the joystick from the neutral (center) position, the electromagnetic brake will release and allow the power chair to move. The further you push the joystick from its neutral position, the faster your power chair will move. When you release the joystick and allow it to return to the neutral position, you engage the electromagnetic brake. This helps the power chair decelerate and come to a complete stop. You can also use the joystick control power actuators.



WARNING! If your power chair begins to move in an unexpected manner, immediately release the joystick. Unless the joystick is damaged, this action should stop your power chair.

Out Of Neutral At Power Up

Your power chair joystick is equipped with Out Of Neutral At Power Up (OONAPU). If you power up the system and the joystick is not in the neutral position, the system status light flashes rapidly for either as long as the joystick is out of the neutral position or five seconds. If this has happened and the all the lights on the battery condition meter are flashing, you may have set flash code 1.

Keypad

The keypad is located directly in front of the joystick. It contains keys that you will use to control your power chair. See figure 32.

VII. OPERATION

On/Off Key

The on/off key turns the system power on and off.



WARNING! Unless faced with an emergency situation, do not use the on/off key to stop the chair. This will cause the power chair to stop abruptly.

WARNING! Always turn the power off when you are stationary to prevent unexpected movement.

NOTE: If the joystick is not in the neutral (center) position when you turn on the power, you may cause a fault in the system. See “Out Of Neutral At Power Up.”

System Status Light

The system status light is normally on when the system is powered up, and off when the system is powered down. It will also flash trouble codes when the system detects a fault. See “Trouble Codes.”

Magnetic Locking Area

Your power chair is equipped with a feature that enables you to “lockout” unauthorised users. For this function, you will need the magnetic key supplied with your power chair. If you lose this key, contact your authorised Pride Dealer.

To enable the lockout system:

1. Hold the magnetic key on or near the key symbol. The system will beep and automatically turn off.

NOTE: None of the remote lights should be lit.

2. Press the on/off key to turn on the power chair. The key symbol will flash, but you will not be able to drive your power chair. This means that it is still locked.
3. Hold the magnetic key on or near the key symbol again to unlock the system. When the key symbol stops flashing, you may turn on the power chair.

NOTE: If you turn on the power chair while it is locked and don't unlock it after one minute, the power chair will automatically turn off itself.

Battery Condition Meter

The battery condition meter consists of six lights arranged in an arc over the battery icon. From left to right, the first two are red, the second two are orange and the last two are green. These lights give you an accurate indication of your usable battery capacity. If the battery has at least 85% of its rated capacity, all of the lights will be on. As the battery voltage drops, the number of lights reduces from right to left. When the battery capacity drops to 10% or below, all of the lights will flash once every second.

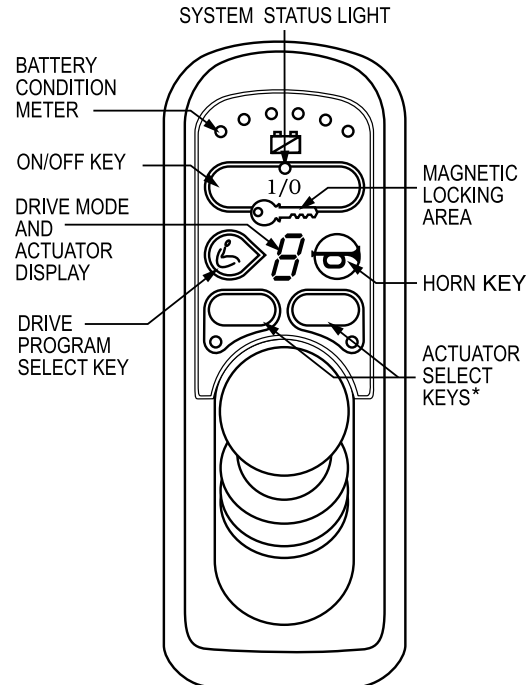

*These are optional accessories. Please contact your authorised Pride provider for more information.

Figure 32. Europa Master Remote Keypad

VII. OPERATION

Drive Program Select Key

The drive program select key enables you to select a drive program and an actuator mode. Your Dynamic DX controller was preprogrammed at the factory for five drive programs— 1 (slowest) to 5 (fastest). The drive mode is indicated by a number in the center of the keypad.

NOTE: The drive mode settings are preset at the factory. If your authorised Pride Dealer changes these settings, please make note of these changes.

To change the drive mode program:

1. Press the drive program select key.
2. Move the joystick right to increase the drive mode program.
3. Move the joystick left to decrease the drive mode program.
4. Press the drive mode select key.

Drive Mode and Actuator Display (also Remote Status Display)

This is a seven-segment light that displays the drive program. It also displays a drive inhibit and actuator mode (if applicable), when they occur.

Actuator Select Keys with Lights

If your power chair is equipped with power accessories such as a power seat or power elevating leg rests, you can operate them through the remote keypad. Contact your authorised Pride Dealer for information on how to operate these accessories.

Remote Status Light

This light will flash if there is an internal Dynamic DX Remote fault, or if an OONAPU fault has occurred. See “Out Of Neutral At Power Up.”

Horn Key

The horn key activates the horn.

Battery Saver Feature

When the battery capacity drops to below 21V (typically two lights), the controller will reduce power chair performance to conserve battery power.

Off-board Charger/Programming Socket

You may use an off-board charger to charge the power chair batteries through the 3-pin socket located on the front of the Europa. See figure 31. If you use an off-board charger, the charger current should not exceed 8 amps. Contact your authorised Pride Dealer for more information.

NOTE: The socket may also be used for reprogramming the Europa. Contact your authorised Pride Dealer for more information.

VII. OPERATION

Sleep Mode (If Enabled)

The power chair controller features a sleep mode. Sleep mode is a built-in circuit that will automatically shut off the main power if the joystick is not moved in any direction for a period of time. This time factor is programmed into the controller. To restore power and continue, push the on/off key on the keypad.

Trouble Codes

The system status light is displayed within the on/off key. This light is lit if the system is turned on. It also flashes in groups called flash codes, to indicate system faults. The table below identifies the individual fault codes. If your keypad displays one of these codes, contact your authorised Pride Dealer.

FLASH CODE SEQUENCE	DIAGNOSIS	SOLUTION
•—•—•—	DX module fault	See your authorised Pride dealer.
••—••—••—	DX accessory fault	See your authorised Pride Dealer.
•••—•••—	Left motor (or connection) fault	Check left motor wiring.
••••—••••—	Right motor (or connection) fault	Check right motor wiring.
•••••—•••••—	Left park brake fault	Check motor/brake wiring.
••••••—••••••—	Right park brake fault	Check motor/brake wiring.
•••••••—•••••••—	Low battery fault	Check that the battery wiring is secure.
••••••••—••••••••—	Over voltage fault	Check that the battery wiring is secure.
•••••••••—•••••••••—	CANL fault	See your authorised Pride Dealer.
••••••••••—••••••~	CANA fault	See your authorised Pride Dealer.
•••••••••••—••••••~	Stall timeout	Turn unit on, then off.
••••••~••••••~	Module mismatch	See your authorised Pride Dealer.

NOTE: You must turn the controller off and then on again to reset the controller, even if the source of the fault is removed/corrected.

In the event of a fault, the system status light displays diagnostic indications. Faults are encoded as follows: one (for a low battery voltage fault) to twelve (module mismatch) and are displayed by the light flashing the number of times prescribed by the fault code. The flash sequence (one to twelve) is followed by a long off period (2 seconds). If more than one fault exists, then the fault having the highest priority is indicated. The controller must be turned off and then on again even if the source of the fault is removed. If you cannot resolve the problem, contact your authorised Pride Dealer.

VIII. BATTERIES AND CHARGING

BATTERIES AND CHARGING

Your Jazzy 1113 uses two long-lasting, 12-volt batteries. These are sealed, maintenance free, deep-cycle batteries. Since they are sealed, there is no need to check the electrolyte (fluid) level. Deep-cycle batteries are designed to handle a deep discharge. Though they are similar in appearance to automotive batteries, they are not interchangeable. Automotive batteries are not designed to handle a long, deep discharge, and are also unsafe for use in power chairs.



WARNING! Battery posts, terminals, and related accessories contain lead and lead compounds. Wash hands after handling.

CHARGING YOUR BATTERIES

The battery charger is one of the most important parts of your Jazzy 1113. The battery charger is designed to optimise your Jazzy 1113's performance by charging the batteries safely, quickly, and easily. The charging system consists of the charger, the charger fuse, and the ammeter. The onboard charger is located on the battery tray. The charger fuse and the ammeter are located on the electronics tray. The ammeter indicates the rate of charge necessary to fully recharge the batteries. It is also a good indication of whether or not the charger is working. The ammeter and the charger are only functional when the charger power lead is plugged into a wall outlet.



WARNING! You must recharge your Jazzy 1113's batteries with the supplied onboard or off-board charging system. Do not use an automotive-type battery charger.



WARNING! Never use an extension lead to plug in your battery charger. Plug the charger directly into a properly wired standard wall outlet.

To charge the batteries by using the onboard charger:

1. Position the rear of your Jazzy 1113 close to a standard wall outlet.
2. Be certain that the controller power is turned off and the freewheel levers are in the engaged position. See III. "Your Power Chair."
3. Extend the charger power lead and plug it into the wall outlet. The Jazzy 1113 incorporates an inhibit function that disables the power chair when the charger is plugged into a wall outlet.
4. The ammeter indicates how much charge is needed to fully charge the batteries. Wait about a minute for the charger to warm up. The ammeter may move up to as high as 5.5 amps, then gradually move back down to 0 amps as it charges.
5. We recommend you charge the batteries for 8 to 14 hours. As the batteries charge, the ammeter needle will slowly drop to zero. When the batteries are fully charged, the needle will vibrate on or about the zero mark on the meter scale.
6. When your Jazzy 1113's batteries are fully charged, unplug the power lead from the wall outlet, wind it up, and store it in the seat pouch located on the back of the seat.

OFF-BOARD CHARGER

Your Jazzy may be equipped with an off-board, or external, charger. Typically, external chargers plug into the controller. If your Jazzy is equipped with an external charger, refer to the instructions that come with the charger.

VIII. BATTERIES AND CHARGING

BATTERY BREAK-IN

To break in your Jazzy's new batteries for maximum efficiency:

1. Fully recharge any new battery prior to initial use. This will bring the battery up to about 90% of its peak performance level.
2. Run your Jazzy 1113 about the house and grounds. Move slowly at first, and do not stray too far until you become accustomed to the controls and break in the batteries.
3. Give the batteries another full charge of 8 to 14 hours and run the Jazzy 1113 again. The batteries should now perform at over 90% of their potential.
4. After four or five charging cycles, the batteries will top off at 100% charge and last for an extended period.

BATTERIES AND CHARGING—FREQUENTLY ASKED QUESTIONS (FAQS)

How does the charger work?

The battery charger takes the standard wall outlet voltage of 120VAC (alternating current) and converts it to 28VDC (direct current). When the battery voltage is low, the charger works harder to charge the batteries. This is why the charging ammeter initially reads 5.5 or more amps. As the battery voltage approaches a full charge, the charger doesn't work as hard to complete the charging cycle. This explains why the amperage on the charging ammeter drops as the batteries approach a full charge. When the batteries are fully charged, the amperage from the charger is nearly zero. This is how the charger maintains a charge but does not overcharge the battery. Your Jazzy 1113's charger will not be able to charge your batteries after the batteries have been discharged to nearly zero voltage. If this happens, call your authorised Pride Dealer for assistance.

Can I use a different battery charger?

You should use the charger supplied with the Jazzy 1113. It is the safest, most efficient tool to charge the batteries. We do not recommend using other types of chargers (e.g., an automotive battery charger).

How often must I charge the batteries?

Many factors come into play when deciding how often to charge the batteries. You may use your Jazzy 1113 all day on a daily basis, or you may not use it for weeks at a time.

■ **Daily Use**

If you use your Jazzy 1113 on a daily basis, charge the batteries as soon as you are finished using it for the day. Then, your Jazzy 1113 will be ready each morning to give you a full day's service. We recommend that you charge the batteries 8 to 14 hours after daily use. Do not charge the batteries for more than 24 hours.

■ **Infrequent Use**

If you use your Jazzy 1113 infrequently (once a week or less), you should charge it at least once per week for 12 to 14 hours.

NOTE: Keep the batteries fully charged and avoid deeply discharging the batteries. Do not charge the batteries for more than 24 hours.

VIII. BATTERIES AND CHARGING

How can I get maximum range or distance per charge?

Rarely do you have an ideal driving situation such as smooth, flat, hard terrain with no hills or curves. More often you are presented with hills, pavement cracks, uneven and loosely packed surfaces, and curves. All of these factors affect the distance or running time per battery charge. The following are a few suggestions for obtaining the maximum range per charge:

- Always charge the batteries fully prior to your trip.
- Maintain **2-2.4 bar (30-35 psi)** in pneumatic drive tyres.
- Plan your trip in advance to avoid inclines if possible.
- Limit the baggage weight to essential items.

What type of battery should I use?

We recommend deep-cycle batteries that are sealed and maintenance free. Both AGM and Gel-Cell are deep-cycle batteries and are similar in performance.

Use these specifications to reorder deep-cycle batteries.

Battery Specifications	
Type:	Deep-Cycle AGM or Gel- Cell
Size:	U-1
Voltage:	12 volts each
Amp Hours:	35 amp hours



WARNING! Corrosive chemicals contained in batteries. Use only AGM or Gel-Cell batteries to reduce the risk of leakage or explosive conditions.

Why do my new batteries seem weak?

Deep-cycle batteries employ a different chemical technology than that used in car batteries, nickel-cadmium (nicads), or in other common battery types. Deep-cycle batteries are specifically designed to provide power, drain down their charge, and then accept a relatively quick recharge. Lead acid batteries should be charged as often as possible. They do not have a “memory” like nickel-cadmium batteries.

We work closely with our battery manufacturer to provide a battery that best suits the Jazzy 1113’s specific demands. Fresh batteries arrive regularly and are promptly shipped with a full charge. During shipping, the batteries encounter temperature extremes that may influence their initial performance. Heat robs the charge from the battery, and cold slows the power available and extends the time needed to recharge the battery (just as with a car battery).

It might take a few days for the temperature of the battery to stabilise and adjust to its new ambient temperature. More importantly, it takes a few “charging cycles” (a partial drain, then a full recharge) to establish the critical chemical balance that is essential to the battery’s peak performance and long life. It is well worth it for you to take the time to break in the batteries properly.

NOTE: The useful life of a battery is quite often a reflection of the care it receives.

VIII. BATTERIES AND CHARGING

How can I ensure maximum battery life?

A fully charged deep-cycle battery provides reliable performance and extended battery life. Keep your Jazzy's batteries fully charged whenever possible. Batteries that are regularly and deeply discharged, infrequently charged, or stored without a full charge may be permanently damaged, causing unreliable Jazzy operation and limited battery life.

How should I store my Jazzy 1113 and batteries?

If you do not use your Jazzy 1113 regularly, we recommend maintaining battery vitality by charging the batteries at least once a week.

If you do not plan on using your Jazzy 1113 for an extended period, fully charge the batteries prior to storage. Disconnect the battery harnesses and store the Jazzy in a warm, dry environment. Avoid temperature extremes such as freezing conditions and excessively hot conditions, and never attempt to charge a frozen battery. A cold or frozen battery should be warmed for several days prior to recharging.

NOTE: If you are storing a Jazzy 1113 for an extended period of time, you may wish to block the unit up off the ground with several boards under the frame. This keeps the tyres off the ground and prevents the possibility of flat spots developing.

What about public transportation?

If you intend to use public transportation while using your Jazzy, you must contact in advance the transportation Dealer to determine their specific requirements. See II. "Safety" for more details.

AGM and Gel-Cell batteries are designed for application in power chairs and in other mobility vehicles. Generally, AGM batteries are safe for all forms of transportation such as aircraft, buses, and trains. We suggest that you contact your transportation Dealer to determine specific requirements of transportation and packaging.

What about shipping?

If you wish to use a freight company to ship the Jazzy 1113 to your final destination, repack the Jazzy 1113 in the original shipping container and ship its batteries in separate boxes.

IX. CARE AND MAINTENANCE

ROUTINE MAINTENANCE

Your Jazzy is a sophisticated power chair. Like any motorised vehicle, it requires routine maintenance checks. You can perform some of these checks, but others require assistance from an authorised Pride Dealer. Preventive maintenance is very important. If you follow the maintenance checks in this section as scheduled, you can help ensure that your Jazzy gives you years of trouble-free operation. If you have any doubt as to your Jazzy's care or operation, contact your authorised Pride Dealer.



CAUTION! Your Jazzy 1113, like most electrical equipment, is susceptible to damage from the elements. Avoid damp areas of any kind. Direct exposure to water or dampness could cause the power chair to malfunction electronically and mechanically. Water can cause electrical components to corrode and the chair's frame to rust.

Should your Jazzy 1113 come in contact with water:

1. Dry your Jazzy 1113 as much as possible with a dry towel.
2. Allow your Jazzy 1113 to sit in a warm, dry place for 24 hours to allow unseen water to evaporate.
3. Check the joystick operation and the brakes before using your Jazzy again.
4. If any inconsistencies are found, take your Jazzy 1113 to an authorised Pride Dealer.

TEMPERATURE

Some of the parts of your Jazzy 1113 are susceptible to extreme changes in temperature. Always keep your Jazzy 1113 between the temperatures of 0° C/32° F and 50° C/122° F.

- In extremely cold temperatures, the batteries may freeze. The specific temperature at which they freeze depends on a number of factors such as battery charge, usage, and composition of the batteries (e.g., AGM or Gel-Cell).
- Temperatures above 50° C/122° F may cause the Jazzy 1113 to operate at a reduced speed. This is a safety feature built into the controller that helps prevent damage to the motor and other electrical components. See VII. "Operation" in this manual.

GENERAL GUIDELINES

- Avoid knocking or bumping your controller, especially the joystick.
- Avoid prolonged exposure of your Jazzy to extreme conditions such as heat, cold, or moisture.
- Keep the controller clean.
- Check all connections on the electronics connector housing to ensure that they are all tight and secured properly. Also, check the charger harness connector.
- When the battery condition meter is completely lit, the batteries are fully charged, and the controller and electrical system are OK.
- If one red bar on the battery condition meter is blinking slowly, the batteries are low and need to be charged, but the controller and electrical system are OK.
- If the battery condition meter is blinking rapidly, the controller has detected a fault in either its own circuits or in the Jazzy's circuits. See VII. "Operation" in this manual.

IX. CARE AND MAINTENANCE



WARNING! Overinflating tyres can cause them to explode and can result in personal injury.

WARNING! Do not use a high pressure hose to inflate your tyres.

- Use a rubber conditioner on the tyre sidewalls to help preserve them. Check the tyres for wear.



WARNING! Never use a rubber conditioner on the tread area of the tyres; doing so may make the tyres slippery and cause your Jazzy to skid.

- The body shroud has been sprayed with a clear sealant coating. You can apply a light coat of car wax to help it retain its high-gloss appearance.
- Check all electrical connections. Make sure they are tight and are not corroded. Batteries must sit flat within the battery area, with the battery terminals facing inward toward each other. Refer to the frame decal for the correct wiring layout.
- All wheel bearings are pre-lubricated and sealed. They require no subsequent lubrication.

DAILY CHECKS

- With the controller turned off, check the joystick. Make sure it is not bent or damaged and that it returns to the neutral position when you release it. Check the rubber boot around the base of the joystick for damage. Visually inspect the boot only. Do not handle or try to repair it. See your authorised service center if there is a problem.
- Visually inspect the controller harnesses. Make sure that they are not frayed, cut, or have any wires exposed. See your authorised Pride Dealer if there is a problem with any of these harnesses.

WEEKLY CHECKS

- Disconnect and inspect the controller from the electronics tray. Look for corrosion. Contact your authorised Pride Dealer if necessary.
- Ensure that all parts of the controller system are securely fastened to your power chair. Do not overtighten any screws.
- Check for proper tyre inflation. There should be **2-2.4 bar (30 – 35 psi)** in each tyre. If a tyre does not hold air, see an authorised Pride Dealer for replacement of the tube.
- Calibrate the joystick if a noticeable difference in performance is detected or if the joystick does not operate properly. To calibrate the joystick, power off the unit, place the joystick in the neutral position, and power the unit back on. If a problem still exists with your joystick's performance, contact your authorised Pride Dealer.
- Check the brakes. This test should be carried out on a level surface with at least one meter of clearance around your power chair.

To check the brakes:

1. Turn on the controller and turn down the speed level of your power chair.
2. After one second, check the battery condition meter. Make sure that it remains on.
3. Slowly push the joystick forward until you hear the electric brakes click. Immediately release the joystick. You must be able to hear each electrical brake operating within a few seconds of joystick movement. Repeat this test three times, pushing the joystick rearwards, then left, and then right.

IX. CARE AND MAINTENANCE

To calibrate the joystick (Remote Plus only):

1. Position the joystick in the full reverse position and hold it there. Turn on the controller.
2. The battery condition meter lights up from one light to ten lights, and then back to one light. It does this twice, then blinks rapidly.
3. Turn off the controller.
4. Position the joystick in the full forward position and hold it there; then turn the controller on.
5. The battery condition meter lights up from one light to ten lights, and then back to one light. It does this twice, then blinks once, and then it blinks continuously.
6. Turn off the controller. Now the joystick and controller are set up to function properly together.

MONTHLY CHECKS

- Check that the anti-tip wheels do not rub the ground when you are operating the Jazzy; adjust them as necessary. See V. “Comfort Adjustments” in this manual.
- Check for extreme wear on the anti-tip wheels. Replace them as necessary.
- Check for drive tyre wear. See an authorised Pride Dealer for repair.
- Check the rear casters for wear. Replace as necessary.
- Check the rear forks for damage or fluttering which indicates that they may need to be adjusted or the bearings may need to be replaced. See an authorised Pride Dealer for repair.
- Keep your Jazzy clean and free of foreign material such as hair, food, drink, etc.

YEARLY CHECKS

Take your Jazzy to an authorised Pride Dealer for yearly maintenance. This helps to ensure that your Jazzy is functioning properly and helps prevent future complications.

STORAGE

Your power chair should be stored in a dry place, free from temperature extremes. When storing, disconnect the batteries from the power chair. See VIII. “Batteries and Charging.”



WARNING! If you fail to store the unit properly, the frame can rust and the electronics can be damaged.

CLEANING PRECAUTIONS



CAUTION! Never hose off your power chair or place it in direct contact with water. Your power chair has a painted, ABS plastic body shroud that allows it to be easily wiped clean with a damp cloth.

CAUTION! Never use any chemicals to clean a vinyl seat, as they may cause the seat to become slippery or dry out and crack. Use soapy water and dry the seat thoroughly.

Your power chair, like most electrical equipment, is susceptible to damage from the elements. Avoid damp areas of any kind.

IX. CARE AND MAINTENANCE



CAUTION! Direct exposure to water or dampness could cause the power chair to malfunction electronically and mechanically. Water can cause electrical components to corrode and the chair's frame to rust.

TYRES AND TUBES

If your Jazzy 1113 is equipped with pneumatic tyres, you should check the air pressure at least once a week. This prolongs the life of your tyres and helps to ensure the perfect operation of your chair. If you have a flat tyre, replace the tube. Replacement tyres and tubes are readily available through the dealer where you purchased your Jazzy 1113.



WARNING! To avoid possible injury, be sure that the controller's power is turned off and the power chair is not in freewheel mode before performing this procedure.

WARNING! Completely deflate the tyre before attempting repair.

Follow these easy steps for a quick and safe tube or tyre replacement:

1. Completely deflate the tyre (if pneumatic).
2. Remove the nut from wheel axle. See figure 33.
3. Pull the wheel off of the axle.
4. Separate the tyre and tube from the wheel.
5. Remove the old tube and/or tyre and replace with new tube or tyre.
6. Slide the wheel back onto the shaft and torque the nut to 16 ft.-lbs.
7. Inflate the tyre to **2 - 2.4 bar (30 - 35 psi)** (if pneumatic).

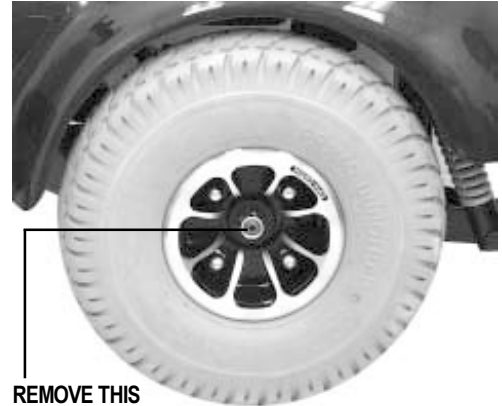

REMOVE THIS
NUT & WASHER TO REMOVE WHEEL

Figure 33. Drive Wheel



Figure 34. Disconnecting Battery Box Connections



Figure 35. Battery Box Removal

IX. CARE AND MAINTENANCE

BATTERY REPLACEMENT



WARNING! Battery posts, terminals, and related accessories contain lead and lead compounds. Wear goggles and gloves when handling batteries and wash hands after handling.

WARNING! Pride Power Chair batteries are heavy. See specifications table. If you are unable to lift that much weight, be sure to get help. Lifting beyond your capacity can result in personal injury.

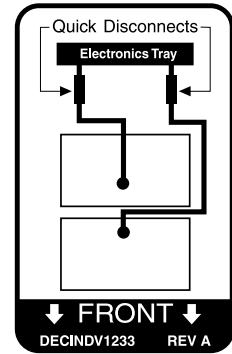

Figure 36. Battery Wiring Diagram

To replace the batteries:

1. Disconnect the controller cable and remove the seat. See IV. “Disassembly.”
2. Disconnect the front battery box and rear battery box from the electronics tray. See figure 34.
3. Lift out each battery box, one at a time, and set them on a solid, flat surface. See figure 35.
4. Unfasten the battery box straps on bottom of box.
5. Lift up the top cover.
6. Remove the rubber covers off the terminals. Unscrew the terminal nuts and bolts and disconnect the battery wires from the battery terminals.
7. Remove the battery from the bottom cover.
8. Place the new battery into the bottom cover.
9. Connect the red battery wire to the (+) positive terminal. Make sure you tighten the nuts and bolts so that the connection is secure.
10. Connect the black battery wire to the (-) negative terminal. Make sure you tighten the nuts and bolts so that the connection is secure.
11. Place the rubber covers over the terminals.



WARNING! Make sure you tighten the fasteners so that the connections are secure.

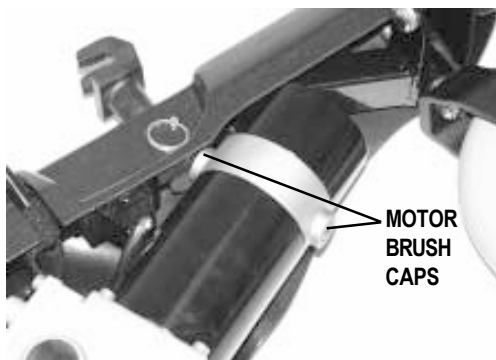

Figure 37. Motor Brush Caps

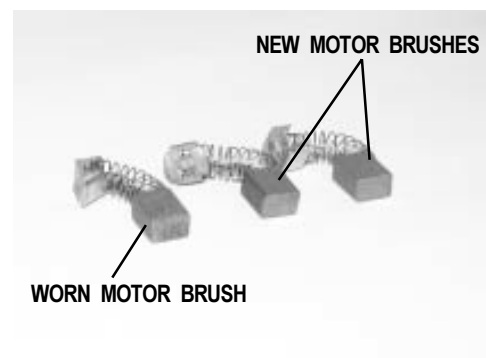

Figure 38. Motor Brushes

IX. CARE AND MAINTENANCE

12. Place the top cover back onto the bottom cover.
13. Fasten the straps and make sure the connection is secure. Place the battery box aside.
14. For the other battery, repeat steps 4 - 12.
15. Make sure that the battery terminals are opposite the battery charger.



WARNING! If you do not position the battery terminals on the opposite side of the charger, you run the risk of shorting out the batteries and severely damaging your Jazzy!

16. Place the rear battery box back into the Jazzy battery well.
17. Place the front battery box back into the Jazzy battery well.
18. Connect the rear battery box connector and the front battery box connector to the electronics tray. See figure 35.
19. Install the seat.
20. Connect the controller cable.

MOTOR BRUSHES

The electric motors that power your Jazzy 1113 use carbon brushes. These brushes may become susceptible to wear over a long period of time. The motor brushes are the two contacts located inside the motor assembly that supply power to the motor. They are designed to provide several thousand hours of operation.



CAUTION! If the brushes become dirty with carbon deposits or wear out, a motor will run poorly or not at all. If inspection determines excessive wear on the brushes, they must be replaced or motor damage will result. Failure to maintain the brushes could void the Jazzy 1113's warranty.

To inspect or replace the motor brushes:

1. Remove the seat and body shroud. See IV. "Disassembly" in this manual.
2. Unscrew the motor brush caps. See figure 37.
3. Remove the brushes.
4. Inspect for wear. See figure 38.
5. Replace the brushes, if necessary. Contact your authorised Pride Dealer for replacement brushes.

CORRECTIVE MAINTENANCE

If the battery condition meter does not light up when you turn on the power:

- Check the harness connections. Make sure they are tight.
- Check the circuit breaker. Reset it if necessary.
- Check the battery connections.

If the above conditions prove normal, you can load test the batteries with a battery load tester. These testers are available at automotive parts stores. Disconnect both batteries before load testing, and follow the directions that came with the load tester. If either one of the batteries fails the load test, replace both of them. If your Jazzy 1113 still does not power up, contact your authorised Pride Dealer.

IX. CARE AND MAINTENANCE

WHEN TO SEE YOUR PRIDE DEALER FOR SERVICE

The following symptoms could indicate a serious problem with your Jazzy 1113. If necessary, contact an authorised Pride Dealer. When calling, have the model number, serial number, nature of the problem, and the trouble code if available.

- Motor noise
- Frayed harnesses
- Cracked or broken connectors
- Uneven wear on any of the tyres
- Jerky motion
- Pulling to one side
- Bent or broken wheel assemblies
- Does not power up
- Powers up, but does not move

X. OPTIONAL ACCESSORIES

The following accessories are available from your authorised Pride Dealer.

POSITIONING BELT

The positioning belt is designed to support the operator's torso so that he or she does not slide down or forward in the seat. The positioning belt is not designed for use as a restraining device. Make sure the belt is secure but does not cause discomfort.



WARNING! The positioning belt is not designed for use as a seat belt in a motor vehicle. Nor is your Jazzy suitable for use as a seat in any vehicle. Anyone traveling in a vehicle should be properly belted into seats approved by the vehicle manufacturer.

OXYGEN TANK HOLDER

The removable oxygen tank holder is mounted to the back of the seat by means of the accessory bracket.

WALKER HOLDER

The removable walker holder is mounted to the back of the seat by means of the accessory bracket. It can hold a standard size walker.

CANE AND CRUTCH HOLDER

The removable cane and crutch holder is mounted to the back of the seat by means of the accessory bracket.

REAR BASKET

The rear basket is mounted to the accessory bracket. It has a handle that you can use when you remove the basket from the Jazzy 1113.

CUP HOLDER

The cup holder is mounted to the armrest.

SWING-AWAY JOYSTICK BRACKET

This option enables you to move the controller from the front of the armrest to the side of the armrest without disconnecting it.

ELEVATING LEG RESTS

Elevating Leg Rests (ELRs) allow you to raise each leg manually to aid in circulation. The ELRs are length-adjustable to accommodate different size legs.

SWING-AWAY FOOTRESTS

Swing-away Footrests provide the Jazzy 1113 with the ability to swing each footrest to the side for an easier transfer.

SPECIALTY SEATING SYSTEMS

Your Jazzy 1113 may be equipped with specialty seating or the Versa Seat. Please refer to the instructions that come with the seat.

XI. WARRANTY

LIFETIME LIMITED WARRANTY

Structural frame components, including: platform, fork, seat post, and frame welds.

TWO-YEAR LIMITED WARRANTY

Drivetrain, including: differential, motor, and brake.

ONE-YEAR LIMITED WARRANTY

Your Pride Jazzy is fully guaranteed for twelve (12) months from the date of purchase against faults arising due to defects in manufacture or materials. This warranty does not detract from, but is in addition to your legal rights.

All electronic parts, including controllers and battery chargers, have a one (1) year warranty. Servicing to the controller or battery charger must be carried out by your authorised Pride Dealer. Any attempt to open or dismantle these items renders the guarantee void on that item.

NOT COVERED UNDER WARRANTY

This guarantee does not extend to those items which may need replacement due to normal wear and tear (tyres, belts, bulbs, upholstery, plastic shrouds, motor brushes, fuses, and batteries), or damage to the product caused by misuse or accident for which Pride or its agent cannot be held responsible. This warranty does not include labour or service calls.

BATTERIES

Batteries are covered by a twelve (12) month warranty from the original manufacturer.

Gradual deterioration in performance due to being left in a discharged state, left in cold conditions for long periods of time, or worn out through heavy use is not covered.

SERVICE CHECKS AND WARRANTY SERVICE

Warranty service can be performed by your authorised Pride Dealer. Please contact your authorised Pride Dealer for advice on the current cost affecting the service visit.

NOTES

NOTES

Jazzy Power Chairs®

How a Power Chair Should Feel™



Quality Control-Model 1113

Thank you for making the Pride Jazzy your choice in power chairs.

We have thoroughly inspected your Jazzy. The following checkmarks indicate that it has been test driven and inspected.

Model # _____

Serial # _____

Controller

Controller Serial # _____

Inclusion of all Parts

Performance

Fit and Finish



Pride keeps a more detailed report on file at the factory.

Date Inspected

Inspector