

JET
Power Chairs

JET
Power Chairs

JET
Power Chairs

JET
Power Chairs

JET
Power Chairs

JET
Power Chairs

JET
Power Chairs

JET
Power Chairs

JET
Power Chairs

JET 3

Owner's Manual

ATTENTION:
Please read the content
of your owner's manual
before operating your
power chair.



Stylish Design and Premium Performance[®]

Pride
Mobility Products Ltd.

Unit 106, Heyford Park Camp Road
Upper Heyford, Oxfordshire OX25 5HA

www.pridemobility.com

Table of Contents

INTRODUCTION	4
YOUR POWER CHAIR	4
DESCRIPTION	4
SPECIFICATIONS	6
OPERATION	7
HOW TO TRANSFER ONTO AND OFF OF YOUR POWER CHAIR	7
SAFETY PRECAUTIONS	7
MAXIMUM RECOMMENDED INCLINE	8
KERB CLIMBING	8
CORNERS	8
ELECTRICAL SYSTEM	9
ELECTRICAL COMPONENTS AND CONNECTIONS	9
MAIN CIRCUIT BREAKER	9
CHARGING YOUR BATTERIES	9
BATTERY REPLACEMENT	10
FREQUENTLY ASKED QUESTIONS	11
MOTOR/BRAKE ASSEMBLY	11
MANUAL BRAKE RELEASE LEVERS	12
SEATING SYSTEM	13
SEAT HEIGHT ADJUSTMENT	13
ARMREST WIDTH AND HEIGHT ADJUSTMENT	14
ARMREST ANGLE	14
JOYSTICK/CONTROLLER EXTENSION	14
JOYSTICK/CONTROLLER POSITION	15
FOOTREST ANGLE	15
FOOTREST HEIGHT	15
FOOTREST DEPTH	16
POSITINING BELT	16
PILOT CONTROLLER	16
VSI CONTROLLER	18
WHEELS AND SUSPENSION	20
DRIVE WHEEL ASSEMBLY	20
ANTI-TIP WHEEL ASSEMBLY	21
CASTOR WHEEL ASSEMBLY	21
CARE AND MAINTENANCE	22
PREVENTIVE MAINTENANCE	22
HOW TO PREPARE YOUR POWER CHAIR FOR STORAGE	23
CORRECTIVE MAINTENANCE	23
WARRANTY	24

Introduction

Congratulations on the purchase of your new Pride Mobility Products Ltd. (Pride) Power Chair! Your power chair combines an advanced, state-of-the-art design with modern, attractive styling. We are certain that the design features and trouble-free operation of your new power chair will add convenience to your daily living.

Please read and follow all instructions in this owner's manual before attempting to operate your power chair for the first time. If there is anything in this manual you do not understand, or if you require additional assistance for setup, contact your authorised Pride dealer.

Our owner's manuals are compiled from the latest specifications and product information available at the time of publication. We reserve the right to make changes as they become necessary. Any changes to our products may cause slight variations between the illustrations and explanations in our manuals and your power chair. This owner's manual covers the standard equipment available on the Jet 3 Power Chair. Options and accessories are covered separately.

Using your Pride Power Chair safely depends upon your diligence in following the warnings, cautions, and instructions in this owner's manual. It also depends upon your own good judgement and common sense, as well as the judgement and common sense of your provider, carer, or healthcare professional. Pride is not responsible for injuries or damage resulting from any person's failure to follow the warnings, cautions, and instructions in this owner's manual. Pride is not responsible for injuries or damage resulting from any person's failure to exercise good judgement or common sense.

The symbols below are used throughout this manual to identify warnings, cautions, and notes. It is very important for you to read and understand them completely.



WARNING! Failure to heed the warnings in this owner's manual may result in personal injury.



CAUTION! Failure to heed the cautions in this owner's manual may result in damage to your power chair.



NOTE: Important concepts to remember while using your power chair.

If you experience any problems with your power chair that you are unable to resolve or if you do not feel capable of safely following any of the instructions or recommendations contained in this manual, please contact your authorised Pride dealer for assistance.

Once you understand how to operate and take care of your power chair, we are certain that it will give you years of trouble-free service and enjoyment.

Your Power Chair

DESCRIPTION

Your Pride Jet 3 is a motorised, mid-wheel drive power chair that is designed to operate both indoors and outdoors (in clear weather). It is sufficiently compact and maneuverable for some indoor environments but is also capable of negotiating some outdoor obstacles as well.

Your power chair has two main assemblies: the seat and the power base. There are a wide range of seating options for the power chair, as well as custom configurations. Commonly, the seating system consist of a seatback, armrests, joystick/controller, and footrest. See figures 1 and 2. Your power chair may have other specialty features to further enhance your mobility. If your power chair is equipped with other specialty features, refer to the information supplied with those products.

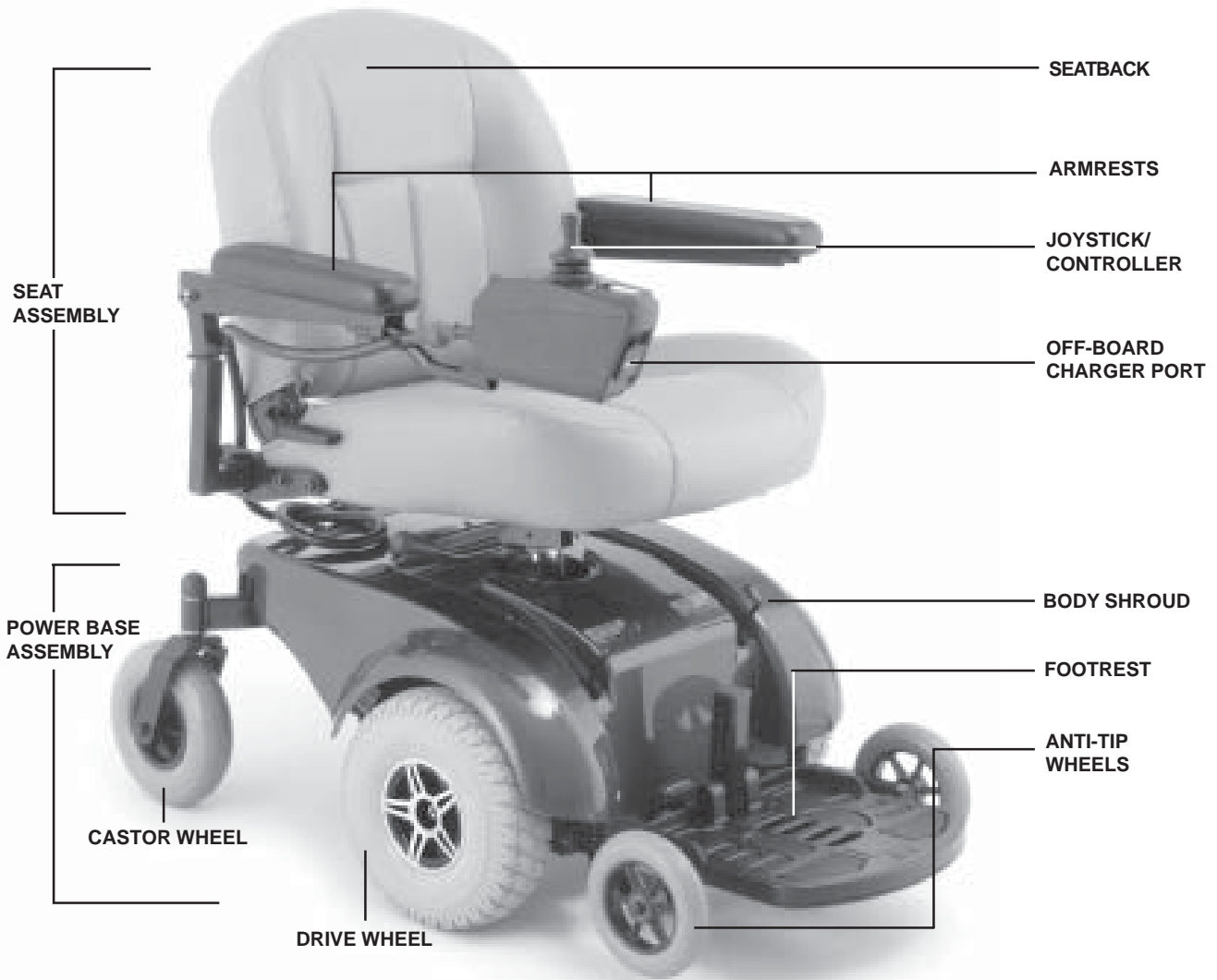

Figure 1. Jet 3

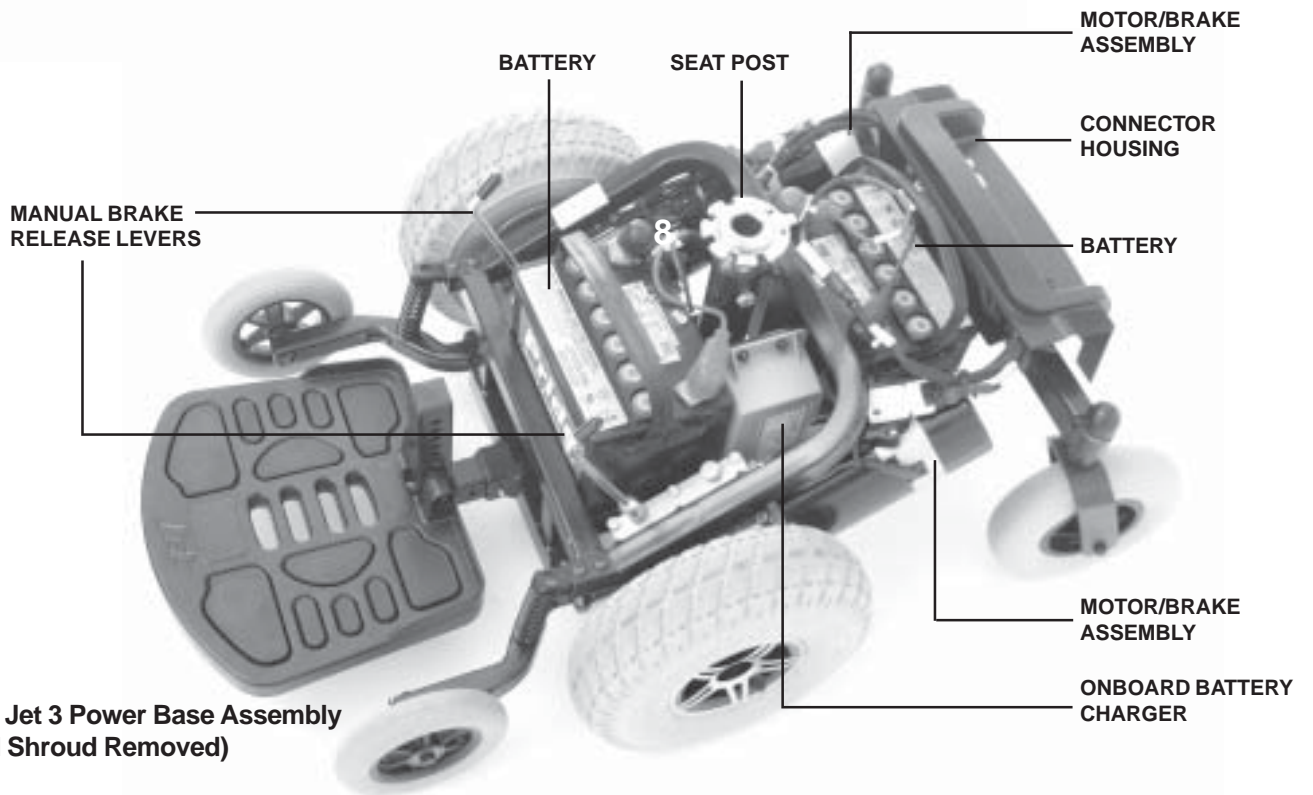

Figure 2. Jet 3 Power Base Assembly (Seat and Shroud Removed)

SPECIFICATIONS

JET 3 SPECIFICATIONS	
Class of Use:	A
Maximum Safe Slope:	8.7%
Maximum Climbing Ability:	8.7%
Maximum Obstacle Climbing Ability:	5 cm
Drive Wheels:	25 cm, center-mounted, solid tyres (pneumatic tyres are optional)
Caster Wheels:	20 cm, solid, rear articulating
Anti-tip Wheels:	15 cm, solid, front mounted
Maximum Speed:	Up to 6 km/h
Brakes:	Electronic, regenerative, "Intelligent Braking"
Ground Clearance:	7.6 cm (3 in.)
Turning Radius:	47 cm 18.5 in.)
Overall Size:	Length: 90 cm (34.5 in.) Width: 58 cm (23 in.)
Seating Options:	High back with headrest
Drivetrain:	Two-motor, rear-wheel
Batteries:	Two 12-volt, U-1 32 AH batteries
Range:	Up to 40 km
Battery Charger:	Onboard (standard) Off-board (optional)
Motor Controller:	P&G VSI (standard) P&G Pilot (optional)
Weight Capacity:	113 kg (250 lb./22 Stone)
Jet 3 Weights:	Base: 43 kg (95 lbs.) Seat: 17 kg (36.5 lbs.) Batteries: 11 kg (24.5 lbs.) each
Warranties:	Five-year limited warranty on frame Two-year warranty on drivetrain One-year warranty on electronics

Tools Required for Service

Your power chair is delivered fully assembled. The seat and batteries can be removed without tools. However, to make adjustments or to service your power chair, you should have access to the following tools:

- set of hex keys or hex bits (SAE and Metric).
- drive socket set (SAE and Metric).
- adjustable spanner.
- spanner set (SAE and Metric).
- set of screwdrivers.

Operation

Your power chair is designed to provide optimum stability under normal driving conditions such as dry, level surfaces composed of concrete, blacktop, or tarmac. However, Pride recognises that there may be times when you will encounter other types of surfaces. For this reason, your power chair can also drive on packed soil, grass, and gravel. Feel free to use your power chair safely on dry lawns and in park areas as well.

Follow these guidelines:

- Reduce your power chair's speed when driving on uneven terrain and/or soft surfaces.
- Avoid tall grass that can get tangled in the running gear.
- Avoid loosely packed gravel and sand.
- If you feel unsure about a driving surface, avoid that surface.
- Check for proper tyre inflation if equipped with pneumatic tyres. **Maintain 30-35 psi (2 - 2.4 bar)** in each drive tyre.

To operate your power chair:

1. Turn on the power.
2. Move the joystick in the desired direction. The farther away from the center you move the joystick, the faster the power chair moves. We recommend setting the joystick/controller to its slowest setting and practicing simple maneuvers with a trained attendant before going off on your own.

HOW TO TRANSFER ONTO AND OFF OF YOUR POWER CHAIR

Transferring onto or off of your power chair safely requires practice. Always have an attendant or healthcare professional present while learning to properly transfer yourself.



WARNING! To eliminate the possibility of injury, Pride recommends that you or a trained attendant perform the following tasks before attempting a transfer:

1. Reduce the distance between your power chair and your transfer destination.
2. Turn the power off.
3. Turn both castor wheels toward the transfer destination to improve power chair stability during transfer.
4. Make sure that your power chair is not in freewheel mode.
5. Make sure the armrests are flipped up or removed from your power chair.
6. Flip the footrest up, or move the leg rests aside; this will help to keep your feet from getting caught on the footrest or on the leg rests during the transfer.

MISSING OR DAMAGED PARTS

Your power chair is shipped fully assembled. If you think that your power chair is either missing parts or some parts are damaged, please contact your authorised Pride dealer immediately.

SAFETY PRECAUTIONS



WARNING! You should not operate your power chair on public streets and roadways. Be aware that it may be difficult for traffic to see you when you are seated on your power chair. Wait until your path is clear of traffic, and then proceed with extreme caution. Obey all pedestrian traffic rules.



WARNING! Never use your power chair to negotiate steps or escalators. You may cause injury to yourself and to others and damage your power chair.



WARNING! Avoid icy or slippery conditions and salted surfaces (i.e., walks or roads).



WARNING! Consult your physician if you are taking prescribed or over-the-counter medication, or if you have certain physical limitations. Some medications and limitations may impair your ability to operate your power chair in a safe manner.



WARNING! Do not operate your power chair while you are under the influence of alcohol, as this may impair your ability to operate your power chair in a safe manner.



WARNING! Do not attempt to drive onto an incline without first checking your brakes. If you attempt to drive onto an incline and the brakes are not functioning correctly, you risk serious injury.

⚠ WARNING! Your power chair's performance may be influenced by electromagnetic fields caused by mobile telephones or other radiating devices, such as hand-held radios, radio and television stations, wireless computer links, microwave sources, and paging transmitters.

⚠ WARNING! Your power chair can be a source of electromagnetic and radio frequency interference.

MAXIMUM RECOMMENDED INCLINE

Pride performs extensive testing on our power chairs. Our results indicate that the maximum slope your power chair can climb safely is 8.7% at maximum weight capacity. See figure 3. Eight-seven percent is the angle of most handicap access ramps. Any attempt to climb a steeper incline may put your power chair in an unstable position.



Figure 3. Maximum Recommended Safe Slope

⚠ WARNING! Although your power chair may be capable of climbing slopes greater than those illustrated above, do not, under any circumstances, exceed the incline guidelines or any other specifications presented in this manual. Doing so could cause instability in your power chair, resulting in personal injury and/or damage to your power chair.

⚠ WARNING! Always exercise extreme caution when negotiating an incline. Do not zigzag or drive at an angle. Drive your power chair straight up the incline. This greatly reduces the possibility of a tip or a fall.

⚠ WARNING! You should not travel up or down a potentially hazardous incline (i.e., areas covered with snow, ice, cut grass, or wet leaves). Pride will not be held responsible for injuries and/or property damage resulting from zigzagging, driving at an angle up the face of an incline, failing to exercise extreme caution when negotiating an incline, and/or traveling on a low traction surface incline.

⚠ WARNING! When on any sort of an incline, never place the power chair in freewheel mode while seated on it or standing next to it.

KERB CLIMBING

If you are going to attempt to climb onto a kerb, approach it slowly and head-on. Try to keep your power chair moving. If you must stop in the middle of the climb, start again slowly and accelerate cautiously.

⚠ WARNING! The front anti-tip wheels may cause trouble when ascending or descending a kerb if they are not adjusted correctly. Contact your authorised Pride dealer for more information.

CORNERS

We do not recommend high cornering speeds. While your power chair is equipped with castor wheels and anti-tip wheels for increased stability, excessively high cornering speeds can still create the possibility of tipping. Factors which affect the possibility of tipping include, but are not limited to:

- cornering speed.
- steering angle (how sharply you are turning).
- riding on uneven road surfaces.
- riding on inclined road surfaces.
- riding from an area of low traction to an area of high traction (such as passing from a grassy area to a paved area, especially at high speed while turning).
- making abrupt directional changes.

⚠ WARNING! To avoid personal injury or property damage, always exercise common sense when cornering. If the situation arises where you have to negotiate a sharp corner, reduce your speed and steering angle (i.e., lessen the sharpness of the turn). This greatly reduces the possibility of a tip or fall.

Electrical System

The electrical system is powered by two long-lasting, 12-volt, deep-cycle batteries. These batteries are connected in series to provide 24 volts of direct current (DC). The main electrical components consist of the batteries, a battery charging system, the main circuit breaker, the motor/brake assembly, and the controller (see figures 1, 2, and 4).

ELECTRICAL COMPONENTS AND CONNECTIONS

The joystick/controller is connected to the battery and the motors through two electrical connections: the controller connector and the charger harness connector. Both are located on the electrical connector housing at the back of the power chair. See figure 4.

Controller Connector: This is where the controller is connected to the batteries and motors.

Charger Harness Connector: This is where the charger connects to the joystick/controller.

MAIN CIRCUIT BREAKER

The main circuit breaker is a safety feature built into your Jet 3. It is located at the back of the power chair. See figure 4. When the batteries and the motors are heavily strained (e.g., from excessive loads), the main circuit breaker will trip to prevent damage to the motors and the electronics. If the circuit breaker trips, allow the Jet 3 to rest for approximately one minute. Then, push in the circuit breaker button, turn on the controller power, and continue normal operation. If the main circuit breaker trips repeatedly, contact your authorised Pride dealer.

CHARGING YOUR BATTERIES

The batteries are sealed and maintenance free, so there is no need to check the electrolyte fluid level. Deep-cycle batteries are designed to handle a longer and deeper discharge. Though they are similar in appearance to automotive batteries, they are not interchangeable.



CAUTION! Automotive batteries are not designed to handle a long, deep discharge, and are unsafe for use in power chairs.

BATTERY CHARGING SYSTEM

The battery charger is essential in providing long life for your power chair's batteries. Your power chair may be equipped with an onboard charger located between the batteries. See figure 2. The ammeter is located on the electronics connector housing, for easy viewing. The 7.5 amp, in-line fuse is located under the electronics connector housing. The in-line fuse protects the entire charger circuit from shorts or bad connections. The ammeter indicates the rate of charge necessary to fully recharge the batteries. The ammeter is also a good indication of whether or not the charger is working. The ammeter and the charger are functional only when the charger power cord is plugged into a wall outlet.



WARNING! You must recharge your Jet 3's batteries with the supplied onboard or off-board charging system. Do not use an automotive-type battery charger.

To charge the batteries using the onboard charger:

1. Position the rear of your Jet 3 close to a standard wall outlet.
2. Be certain the controller power is turned off and the Jet 3 is not in freewheel mode.
3. Plug the charger lead into the receptacle on the connector housing.
4. Extend the charger power lead and plug it into the wall outlet. The Jet 3 incorporates an inhibit function that disables the power chair when the charger is plugged into a wall outlet.
5. The ammeter will indicate how much charge is needed to fully charge the batteries. Wait about a minute for the charger to warm up. The ammeter may move up to as high as 4 amps, then gradually move back down to 0 amps as it charges.
6. We recommend you charge the batteries for 8 to 14 hours. As the batteries charge, the ammeter needle will slowly drop to the zero mark. When the batteries are fully charged, the needle will vibrate on or about the zero mark on the meter scale.

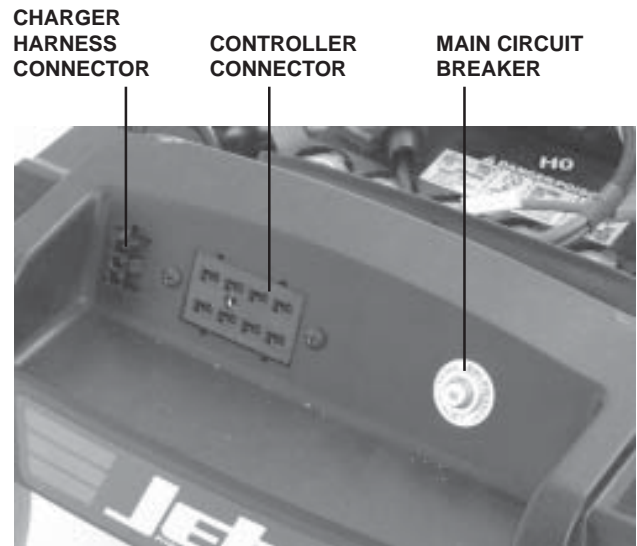

Figure 4. Electronics Tray

- When your Jet 3 batteries are fully charged, unplug the power lead from the wall outlet and from the charger receptacle and store the lead in a safe place.

OFF-BOARD CHARGER

Your Jet 3 may be equipped with an off-board charger. Typically, off-board chargers plug into the joystick controller. (See figure 19.) If your Jet 3 is equipped with an off-board charger, refer to the instructions that come with the charger.

BATTERY BREAK-IN

To break in new batteries for maximum efficiency:

- Fully recharge any new battery prior to its initial use. This brings the battery up to about 90% of its peak performance level.
- Operate your power chair about the house and/or yard. Move slowly at first. Don't drive too far until you become accustomed to the controls and you break-in the batteries.
- Give the batteries another full charge of 8 to 14 hours before operating your power chair again. The batteries should now perform at over 90% of their potential.
- After four or five charging cycles, the batteries top off at 100% charge and should last for an extended period.

BATTERY REPLACEMENT



WARNING! Battery posts, terminals, and related accessories contain lead and lead compounds. Wash hands after handling.



NOTE: It is easier to disconnect the battery harnesses when the batteries are removed from the chair.

- Turn the power off.
- Make sure the Jet 3 is not in freewheel mode.
- Unplug the controller and charger harness connectors.
- Lift the seat up from the seat post.
- Remove the body shroud.
- Locate the two wiring harnesses attached to your batteries. Disconnect these two harnesses from their respective quick disconnects and remove the batteries. See figures 5 and 6. A diagram decal is located on the Jet 3 frame near the battery tray.



NOTE: It is easier to connect the harnesses to the batteries when you have the batteries away from your power chair. This gives you more room to work.

- Connect the wire labeled REAR BATTERY (+) to the battery's positive (red) terminal. Connect the wire labeled REAR BATTERY (-) to the negative (black) terminal. See figure 7. Install the battery in the rear of your Jet 3's battery tray with the battery terminals facing inward, to ward the center of the Jet 3. Plug the wiring harness into the quick disconnect.
- Connect the wire labeled FRONT BATTERY (+) to the

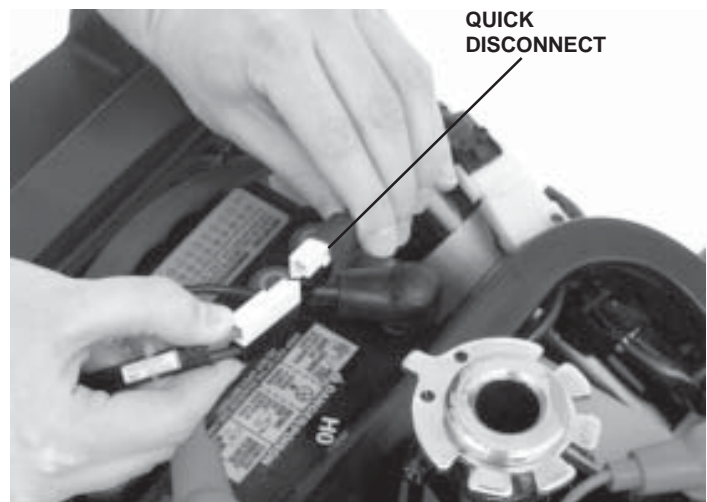

Figure 5. Quick Disconnect



Figure 6. Removing the Batteries from Your Jet 3



Figure 7. Connecting Wires to the Battery Terminals

other battery's positive (red) terminal. Connect the wire labeled FRONT BATTERY (-) to the negative (black) terminal. See figure 7. Install the battery in the front of your Jet 3's battery tray with the battery terminals facing inward, toward the center of the Jet 3. Plug the wiring harness into a quick disconnect.



NOTE: It is important to be sure that your battery connections are tight and secure.

NOTE: The battery wiring diagram decal is located on the front battery box.

9. Dispose of your old batteries in accordance with local disposal laws.

FREQUENTLY ASKED QUESTIONS

HOW OFTEN MUST I CHARGE THE BATTERIES?

If you use your power chair on a daily basis, charge the batteries as soon as you are done using it. Your power chair will be ready each morning to give you a full day's service. If you use your power chair infrequently (once a week or less), charge the batteries at least once per week for 12 to 14 hours.



NOTE: Keep your batteries fully charged and avoid deeply discharging your batteries. Do not charge the batteries for more than 24 hours at a charging cycle.

WHAT TYPE OF BATTERY SHOULD I USE?

We recommend deep-cycle batteries that are sealed and maintenance free. Deep-cycle batteries employ a much different chemical technology than that used in car batteries, in nickel-cadmium batteries (nicads), or in other common battery types. Deep-cycle batteries are specifically designed to provide power, drain down their charge, and then accept a relatively quick recharge. Sealed lead-acid batteries should be charged as often as possible. They do not have a "memory" like nickel-cadmium batteries. Both sealed lead-acid (SLA) and gel cell are deep-cycle batteries that are similar in performance.

Use these specifications to reorder deep-cycle batteries:

Type: Deep-cycle (sealed lead-acid or gel cell)
Size: U-1
Voltage: 12 volts each
Amperage: 30-35 amp hours

HOW SHOULD I STORE MY POWER CHAIR AND ITS BATTERIES?

If you do not use your power chair regularly, we recommend charging the batteries at least once a week.

If you do not plan to use your power chair for an extended period, fully charge the batteries prior to storage. Disconnect the battery harnesses and store the power chair in a warm, dry environment. Avoid temperature extremes, such as freezing and excessively hot conditions, and never attempt to charge a frozen battery. If you encounter a cold or frozen battery, allow it to reach to room temperature prior to recharging.

HOW SHOULD I DISPOSE OF OLD BATTERIES?

If you encounter a damaged or cracked battery, immediately enclose it in a plastic bag and call your authorised Pride dealer for instructions on disposal. Your authorised Pride dealer will also have the necessary information on battery recycling, which is our recommended course of action.



WARNING! Do not attempt to dispose of damaged batteries. If you suspect that your batteries are damaged, contact your authorized Pride dealer immediately.

MOTOR/BRAKE ASSEMBLY

Your power chair is equipped with two motor/brake assemblies, one for each drive wheel. The motor/brake assembly consists of a 24-volt motor, an electronic brake, and a gearbox. The gearbox features a brake release lever that disconnects the motor from the gearbox and enables you to move the chair manually.



Figure 8. Drive Motors Engaged



Figure 9. Drive Motors Disengaged (Freewheel Mode)

MANUAL BRAKE RELEASE LEVERS

For convenience, your Jet 3 is equipped with two manual brake release levers located on the front of your Jet 3. See figure 8 and 9. These levers allow you to disengage the drive motors and maneuver the chair manually.

To engage or disengage the drive motors:

1. Locate the two (2) manual brake release levers protruding through the body shroud.
2. Turn the levers outward to engage the drive motors. See figures 8.
3. Turn the levers inward to disengage the drive motors (freewheel mode). See figure 9.

If a lever is difficult to move in either direction, rock the power chair gently back and forth while turning the levers. The levers should then move to the desired position.



WARNING! Do not disengage the drive motors without an attendant present. Personal injury may result.



WARNING! Do not attempt to disengage the drive motors while seated on your power chair. Personal injury may result. Ask your attendant for assistance.



WARNING! Do not disengage the drive motors while on an incline. The chair could roll uncontrollably on its own, causing personal injury.

MOTOR BRAKE TEST

To check the brakes:

1. Turn on the power and turn down the speed and response adjustment knob. See figure 18.
2. After one second, check the battery condition lights. Make sure that they remain on. See figure 18.
3. Slowly push the joystick forward until you hear the joystick. You must be able to hear each electronic

MOTOR BRUSHES ARE LOCATED UNDER THE CAPS.

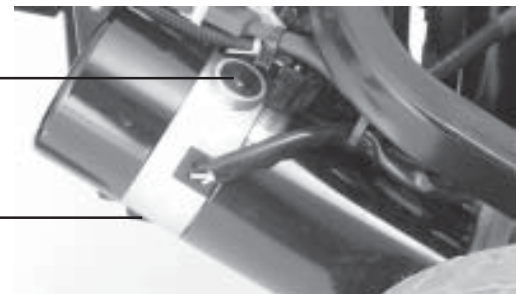

Figure 10. Motor Brush Location

brakes click. Immediately release the brake operating within a few seconds of joystick movement.

- Repeat this test three times, pushing the joystick backwards, then left, and then right. If either brake does not sound like it is engaging, contact your authorised Pride dealer immediately.

MOTOR BRUSHES

The electric motors that propel your power chair use carbon brushes. The motor brushes are the two contacts located inside the motor / brake assembly that supply power to the motor. They are designed to provide several thousand hours of operation. However, if the brushes become dirty with carbon deposits or wear out, the motor may run poorly or not at all. If an inspection determines excessive wear on the brushes, they must be replaced or motor damage will result.

CAUTION! Failure to maintain the brushes could damage your motor/ brake assemblies and void your warranty.

To inspect or replace the motor brushes:

- Remove the battery boxes.
- Unscrew the motor brush caps. There are two on each motor. See figure 10.
- Remove the brushes.
- Inspect for wear, such as black deposits on the brush contact surface.
- Replace brushes, if necessary. Contact your authorised Pride dealer.

Seating System

After you have used your Jet 3 for an extended period of time, you may find the need to make some adjustments to increase your comfort.

WARNING! If your Jet 3 was configured by your authorized Pride dealer, please consult them before making any adjustments. Some adjustments may degrade your Jet 3's performance and safety by changing its center of gravity.

SEAT HEIGHT ADJUSTMENT

You can change the seat height to one of five positions in 2.5 cm (1in.) increments.

To change the seat height:

- Remove the seat and the shroud.
- Use a 14-mm spanner to loosen and remove the hex-head nut and bolt. See figure 11.
- Loosen the seat post base locking nut using a 11-mm spanner and a 5-mm hex key.
- Slide the seat pedestal up or down in the seat post base.
- Align the holes on the seat post and the seat post base.
- Reinstall and tighten the hex-head nut and bolt.
- Retighten the seat post base locking nut.

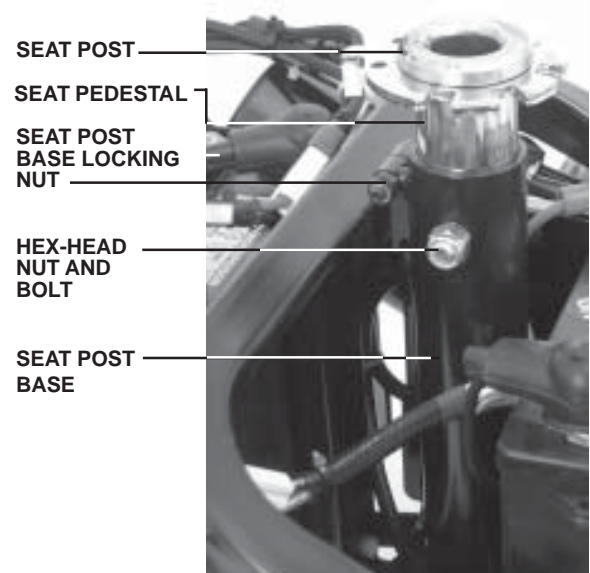

Figure 11. Seat Height Adjustment

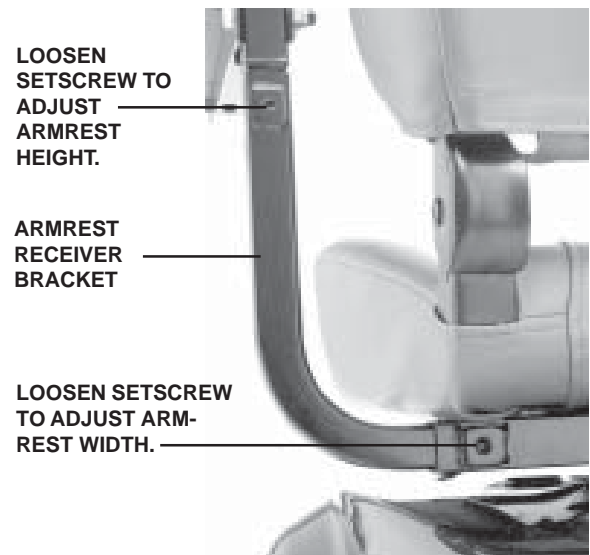

Figure 12. Armrest Width/Height Adjustment

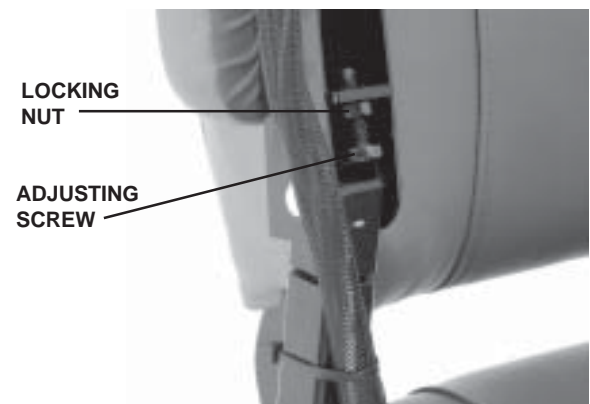

Figure 13. Armrest Angle

ARMREST WIDTH AND HEIGHT ADJUSTMENT

To change the armrest width:

1. Locate the setscrew on the armrest receiver bracket. See figure 12.
2. Loosen the setscrew, and slide the armrest in or out to the desired width.
3. Retighten the setscrew.
4. Repeat for the other armrest.

JOYSTICK MOUNTING
BRACKET

LOOSEN THIS SETSCREW
TO ADJUST THE
JOYSTICK.

To change the armrest height:

1. Loosen the armrest adjustment height setscrew located underneath the armrest. See figure 12.
2. Raise or lower the armrest as desired.
3. Retighten the setscrew.
4. Repeat for the other armrest.

ARMREST ANGLE

You can adjust the armrest angle to fit your specific needs.

To change the armrest angle:

1. Lift the armrest straight up so that it is perpendicular to the floor.
2. Use an 11-mm spanner to loosen the locking nut. See figure 13.
3. Use an 11-mm spanner to loosen the adjusting screw. Turn the screw clockwise to raise the front of the armrest and anticlockwise to lower the front of the armrest.
4. Lock the adjusting screw into place by tightening the locking nut.

JOYSTICK/CONTROLLER EXTENSION

The joystick/ controller can easily slide out away from the armrest or in toward the armrest.

To extend the joystick/controller:

1. Use a 5-mm hex key to loosen the setscrew. See figure 14.
2. Slide the joystick mounting bracket into or out of the armrest to the desired position.
3. Retighten the setscrew by turning it clockwise.

USE A TIE-WRAP TO
SUPPORT THE
CONTROLLER CABLE.

Figure 14. Joystick/Controller Extension

Figure 15. Tie-Wrap Location

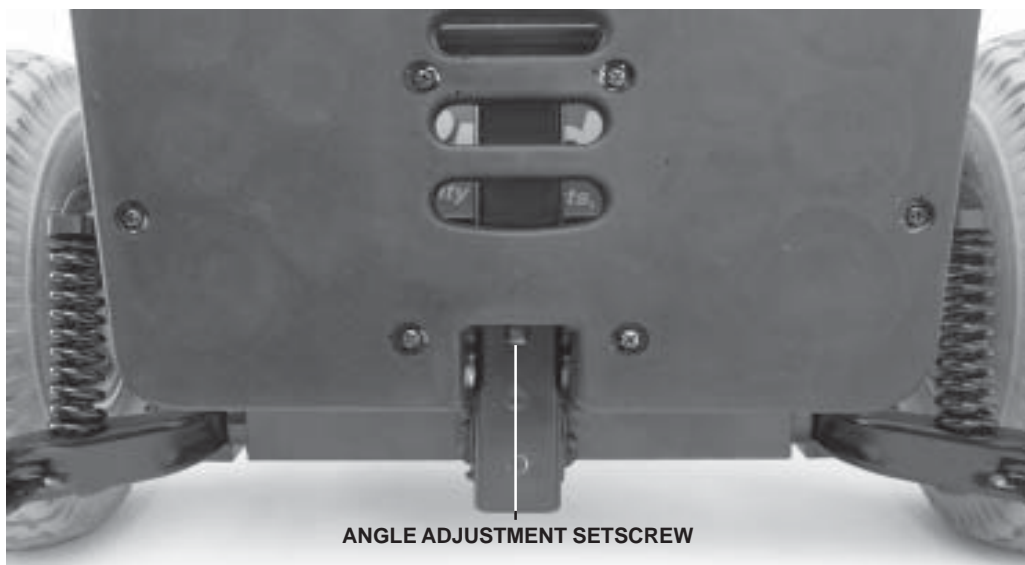

Figure 16. Footrest Angle Adjustment

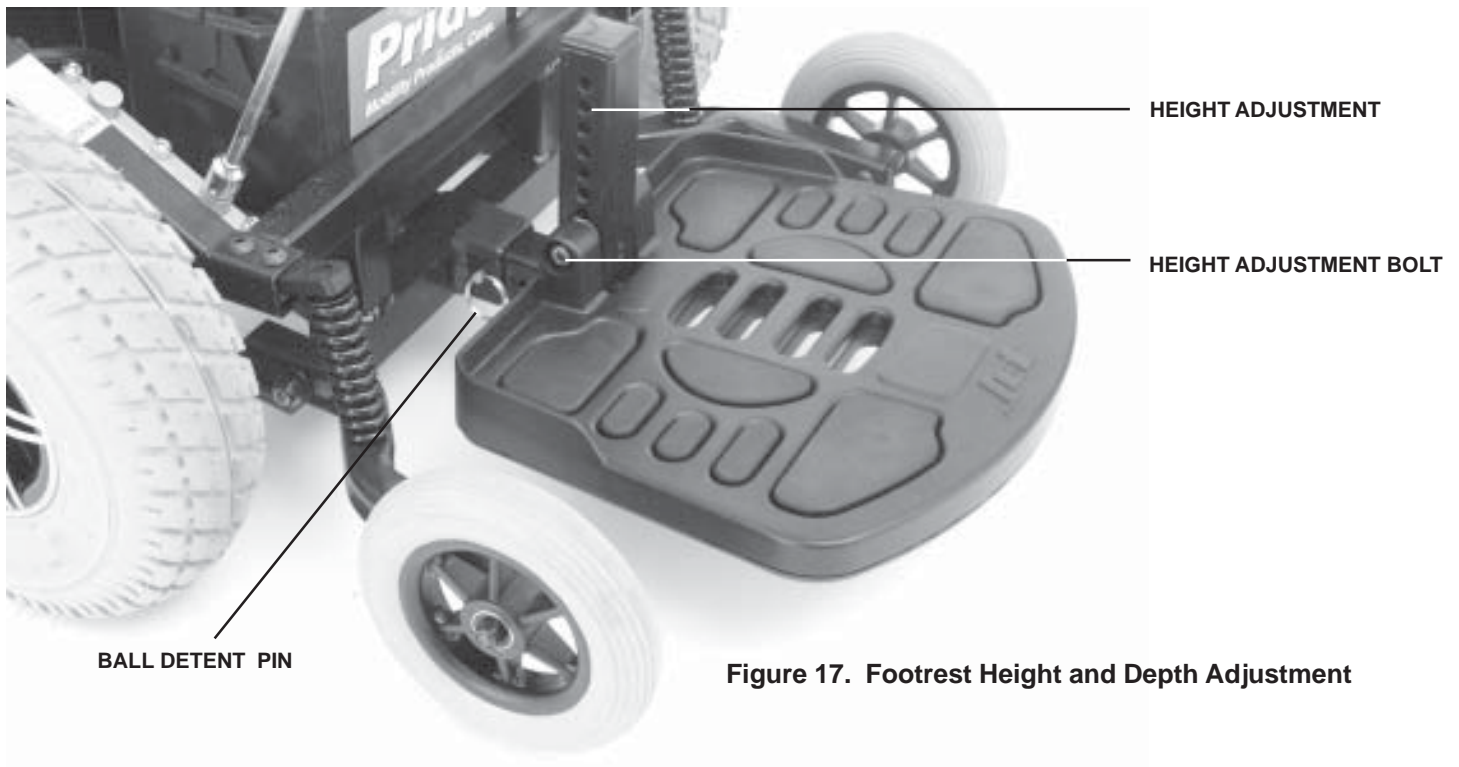

Figure 17. Footrest Height and Depth Adjustment

JOYSTICK/CONTROLLER POSITION

You can position the joystick/ controller for either left-hand or right-hand use.

To change the joystick position:

1. Disconnect the controller and charger harness connectors. See figure 4.
2. Cut the tie-wrap that attaches the controller cable to the armrest. See figure 15.
3. Use a 5-mm hex key to loosen the setscrew. See figure 14.
4. Slide the joystick mounting bracket out of the armrest.
5. Loosen the setscrew in the other armrest.
6. Place the joystick mounting bracket in the other armrest.
7. Tighten the setscrew in each armrest.
8. Connect the controller cable to the armrest with a new tie-wrap. See figure 15.

FOOTREST ANGLE

You can adjust the angle of the footrest with a 5-mm hex spanner. See figure 16.

To adjust the footrest angle:

1. Turn the setscrew clockwise to lower the front of the footrest.
2. Turn the setscrew anticlockwise to raise the front of the footrest.

FOOTREST HEIGHT

The footrest height is easily adjusted to any one of six different heights. See figure 17.

To raise or lower the footrest:

1. Remove the height adjustment bolt from the footrest using a 6-mm hex key and 13-mm socket. See figure 17.
2. Raise or lower the footrest to the desired height.
3. Reinstall the bolt into the footrest.

To adjust the anti-tip wheel height:

1. Remove the seat, the body shroud, and the batteries.
2. Locate the jam nut and bolt on the anti-tip assembly. See figure 22.

FOOTREST DEPTH

The Jet 3 uses a ball detent pin to fasten the footrest to the power base. See figure 17.

To adjust the footrest depth:

1. Remove the ball detent pin from the footrest bracket.
2. Move the footrest in or out to the desired depth.
3. Reinstall the ball detent pin.

POSITIONING BELT

Your power chair seat may be equipped with an adjustable, auto-type positioning belt. The positioning belt is designed to support you so you do not slide down or forward in the seat. The positioning belt is not designed for use as a restraining device.

To install the positioning belt:

1. Remove the rearmost screw that holds the seat hinge to the seat base on both the left and right seat hinges.
2. Insert the screw through the supplied washer, through the positioning belt, and into the seat base for each side.
3. Tighten both screws.

To adjust the positioning belt:

1. When seated, insert the metal tab on the right side of the belt into the plastic housing on the opposite strap until you hear a click.
2. Pull the strap on the right side of the belt until it is secure but not so tight as to cause discomfort.



WARNING! Although your power chair may be equipped with a positioning belt, this belt is not designed to provide proper restraint during motor vehicle transport. Anyone traveling in a motor vehicle should be properly secured in the motor vehicle seat with safety belts securely fastened. Do not sit on your power chair while it is in a moving vehicle. Personal injury and/or property damage may result.

Pilot Controller

Your power chair may be equipped with a Pilot controller. The joystick is housed in the same enclosure as the controller. This assembly is mounted on the seat arm. The Pilot controller is connected to the motors and the batteries through the controller connector and the charger harness connector. See figure 4.

JOYSTICK

The joystick controls the direction and speed of your power chair. When you move the joystick from the neutral (center) position, the electromagnetic brakes release and allow your power chair to move. The farther you push the joystick from its neutral position, the faster your power chair moves. When you release the joystick and allow it to return to the center position, you engage the electromagnetic brakes. This causes your power chair to decelerate and come to a complete stop.



WARNING! If your power chair begins to move in an unexpected manner, immediately release the joystick. Unless the joystick is damaged, this action should stop your power chair.



WARNING! Do not use the power button to stop the chair. This may cause injury.

PEED AND RESPONSE ADJUSTMENT

The Pilot controller is equipped with a speed and response adjustment knob that allows you to select the speed and response settings best suited to your requirements and environment. See figure 18. When you increase the speed (clockwise) or decrease the speed (anticlockwise), appropriate changes are automatically made to the sensitivity.



NOTE: We recommend that the first few times you operate your power chair, you turn the speed and response adjustment knob to the slowest setting until you become familiar with your new power chair.

BATTERY CONDITION LIGHTS

The battery condition lights are located immediately in front of the joystick. This enables you to monitor battery life. The battery condition lights indicates the approximate amount of battery life left.

SPEED AND RESPONSE ADJUSTMENT

The Pilot controller may be equipped with a speed and response adjustment knob that allows you to select the speed and response settings best suited to your requirements and environment. See figure 18. When you increase the speed (clockwise) or decrease the speed (anticlockwise), appropriate changes are automatically made to the sensitivity.



NOTE: We recommend that the first few times you operate your power chair, you turn the speed and response adjustment knob to the slowest setting until you become familiar with your new power chair.

BATTERY CONDITION LIGHTS

The battery condition lights are located immediately in front of the joystick. This enables you to monitor battery life. The battery condition lights indicates the approximate amount of battery life left.

- Red, yellow, and green bars indicate that the batteries are fully charged.
- Red and yellow bars indicate that you should charge the batteries.
- Red bars indicate that you should charge the batteries as soon as possible, because low battery voltage may cause your power chair to become inoperative.



NOTE: When the batteries approach a discharged state, the first red bar will begin to slowly flash, reminding you the batteries need to be charged immediately!

CHARGER INHIBIT CONNECTOR

The charger inhibit connector on the utility tray is coded with colored dots. The dots are positioned so that you align the flat side of the male connector with the flat side of the female connector before making the connection. See figure 4.



CAUTION! Failure to properly align the connectors can result in damage to the controller, the charger harness, and the connectors.

THERMAL ROLLBACK

The Pilot controller is equipped with a thermal rollback circuit. This circuit monitors the temperature of the motors and the controller. In the event that the motors or the controller become excessively hot (above 50C/122F), the controller reduces the motor voltage. For every degree above 50C/122F, the controller reduces the voltage by 5 volts. This reduces your power chair's speed and allows the electrical components to cool down. When the temperature returns to a safe level, your power chair resumes its normal speed.



Figure 18. Pilot Controller

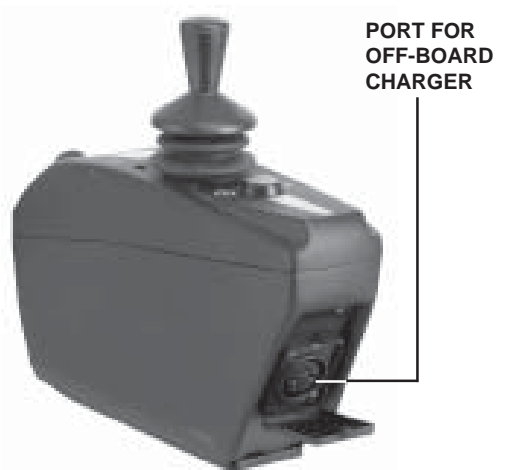

Figure 19. Off-board Charger Port

VSI Controller

The VSI controller is an integral electronic controller. All of the electronics necessary to operate the power chair are contained in one module. See figure 20.

The VSI consists of:

1. joystick
2. keypad (see figure 21)
3. off-board charger/programming socket
4. actuator connector (optional)
5. controller connector
6. 3-pin charger inhibit connector

Typically, the VSI is mounted to one of the armrests and is connected to the motors, batteries, and the onboard charger at the electronics tray.

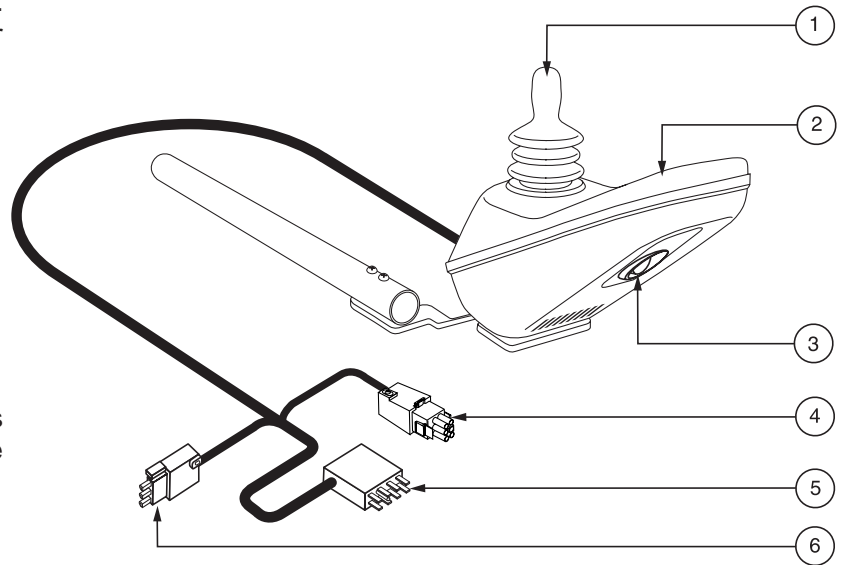

Figure 20. VSI Controller

JOYSTICK

The joystick controls the direction and speed of your power chair. See figure 20. When you move the joystick from the neutral (center) position, the electromagnetic brakes release and allow your power chair to move. The further you push the joystick from its neutral position, the faster your power chair moves. When you release the joystick and allow it to return to the neutral position, you engage the electromagnetic brakes. This causes your power chair to decelerate and come to a complete stop.

⚠ WARNING! If your power chair begins to move in an unexpected manner, immediately release the joystick. Unless the joystick is damaged, this action should stop your power chair.

KEYPAD

The keypad is located in front of the joystick. It contains keys necessary to operate your Jet 3. See figure 21.

ON/OFF KEY

The on/off key turns the VSI on and off. See figure 21.

⚠ WARNING! Unless faced with an emergency situation, do not use the on/off key to stop the chair. This will cause the power chair to stop abruptly.

⚠ WARNING! Always turn the power off when you are stationary to prevent unexpected movement.

BATTERY CONDITION METER

The battery condition meter is located in front of the joystick. See figure 21. This is a 10-segment illuminated display that indicates that the VSI is turned on and also gives the battery status, the VSI status, and the electrical system status.

- **Red, yellow, and green lights lit:** Battery charged; VSI and electrical system OK.
- **Red and yellow lights lit:** Charge battery if possible; VSI and electrical system OK.
- **Red lights only lit or slow flash:** Charge battery as soon as possible; VSI and electrical system OK.
- **Rapid flash of lights:** Indicates a fault in the VSI or the electrical system. Refer to *iVSI Error Codes*.
- **Ripple up and down of lights:** The joystick was not in the neutral position when the controller was turned on. If you get ripple up and down of lights, turn off the controller, allow the joystick to return to the neutral position, then turn on the controller.

i **NOTE:** If you still get “ripple up and down of lights”, contact your authorised Pride provider.

i **NOTE:** When the batteries approach a discharged state, the first red light will begin to slowly flash, reminding you the batteries need to be charged immediately!

SPEED/PROFILE KEYS

There are two keys that control either the speed or the profile. See figure 21. This depends on how your VSI was programmed. Press the speed/profile increase key to increase the speed or change the profile. Press the speed/profile decrease key to decrease the speed or change the profile. The speed/profile setting is displayed in the maximum speed/profile indicator. If your power chair was programmed with a drive profile, contact your authorised Pride provider for more information.

i **NOTE:** We recommend that the first few times you operate your power chair, you set the speed to the slowest setting until you become familiar with your new power chair.

ACTUATOR KEY AND ACTUATOR LIGHTS (FOR OPTIONAL EQUIPMENT)

Actuator keys and actuator lights are used for optional equipment such as power elevating seats or power elevating leg rests. See figure 21. For specific operation of the actuator keys and actuator lights, contact your authorised Pride provider.

HORN KEY

The horn key activates the horn. See figure 21.

OFF-BOARD CHARGER/PROGRAMMING SOCKET

You may use an off-board charger to charge the power chair batteries through the 3-pin socket located on the front of the VSI. See figure 20. If you use an off-board charger, the charger current should not exceed 12 amps. Contact your authorised Pride provider for more information.

⚠ CAUTION! Only chargers with Neutrik NC3MX plugs should be connected to the off-board charger/programming socket. See your authorised Pride provider for more information.

i **NOTE:** The socket may also be used for reprogramming the VSI. Contact your authorised Pride provider for more information.

CONTROLLER CONNECTOR

This connects the VSI to the power chair's batteries, motors, and motor brakes. See figure 20.

3-PIN CHARGER INHIBIT CONNECTOR

This connects the VSI to the onboard battery charger. See figure 20. This connection provides an inhibit that disables the VSI when the battery charger is on. The charger inhibit connector is coded with colored dots. The dots are positioned so that you align the flat side of the male connector with the flat side of the female connector before making the connection.

⚠ CAUTION! Failure to properly align the connectors can result in damage to the VSI, the charger harness, and the connectors.

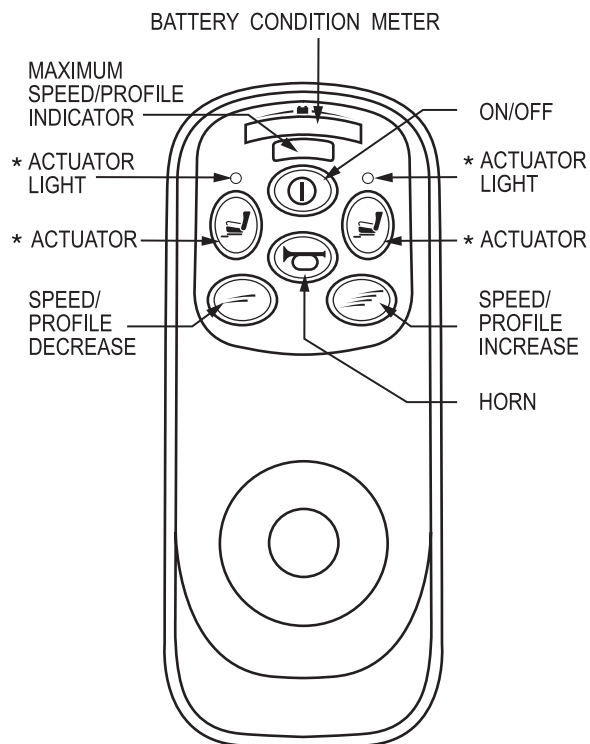

*For optional equipment on some models.

Figure 21. VSI Controller Keypad

THERMAL ROLLBACK

The VSI controller is equipped with a thermal rollback circuit. The circuit monitors the temperature of the controller, which roughly translates to motor temperature. In the event that the VSI controller becomes excessively hot (above 60 C/140 F), motor current (amperage) is reduced. For every degree above 60 C/140 F, the motor current limit is reduced by .55 amps until the VSI controller reaches 70 C/158 F, at which time the current output is reduced to zero. This reduces your power chair's power, which could also reduce your power chair's speed, and allows the electrical components and motors to cool down. When the temperature returns to a safe level, your power chair resumes its normal operation.

TROUBLESHOOTING

The VSI controller is designed with the user's safety as the prime consideration. It incorporates many sophisticated self-test features which search for potential problems at a rate of 100 times per second. If the VSI detects a problem either in its own circuits or in the power chair's electrical system, it may decide to stop the power chair, depending on the severity of the problem. The VSI is designed to maximise the user's safety under all normal conditions. The table below identifies the individual error codes. Error codes are displayed as a rapid flashing of the lights. If you get one of these error codes, contact your authorised Pride provider.

VSI ERROR CODES

Flashing Lights	Diagnosis and Solution
1	The battery needs charging or there is a bad connection to the battery. Check the connections to the battery. If the connections are good, try charging the battery.
2	The left motor has a bad connection. Check the left motor connection.
3	The left motor has a short circuit to a battery connection. Contact your authorised Pride provider.
4	The right motor has a bad connection. Check the right motor connection.
5	The right motor has a short circuit to a battery connection. Contact your authorised Pride provider.
6	The power chair is being inhibited by the battery charger. Unplug the battery charger.
7	A joystick fault is indicated. Make sure that the joystick is in the neutral (center) position before turning on the controller.
8	A controller system fault is indicated. Make sure that all connections are secure.
9	The parking brakes have a bad connection. Check the parking brake and motor connections. Make sure the control system connections are secure.
10	An excessive voltage has been applied to the controller. This is usually caused by a poor battery connection. Check the battery connections.

Wheels and Suspension

Your power chair is equipped with three sets of wheel assemblies: anti-tip wheels, drive wheels, and castor wheels. See figure 1.



WARNING! The drive wheel and castor wheel systems are optimised at the factory and should not be adjusted by the user. If you alter either system, you may alter the power chair's handling characteristics, possibly resulting in serious injury.

DRIVE WHEEL ASSEMBLY

Your Pride Power Chair uses two drive wheels that are directly connected to the motor/gearbox assembly. The drive wheel tyres may have solid inserts and do not require air.

TYRES AND TUBES

If your Jet 3 is equipped with pneumatic tyres, you should check the air pressure at least once per week. This will prolong the life of your tyres as well as help ensure the perfect operation of your chair. If you have a flat tyre, replace the tube. Replacement tyres and tubes are readily available at your authorised Pride dealer.



WARNING! Completely deflate the tire before attempting repair.

Follow these easy steps for a quick & safe tube or tyre replacement:

1. Completely deflate the tyre (if pneumatic).
2. Use a 17 mm socket to remove the nut and washer from wheel axle.
3. Pull the wheel off of the axle.
4. Use a 5 mm hex key to remove the five bolts that hold the two-piece wheel together. The wheel will separate into two pieces.
5. Remove the old tube and/or tyre and replace it with a new tube and/or or tyre.
6. Place the wheel halves together and reinstall the bolts.
7. Slide the wheel back onto the shaft, reinstall the washer, and tighten the nut.
8. Inflate a pneumatic tyre to **30 - 35 psi (2 - 2.4 bar)**.

ANTI-TIP WHEEL ASSEMBLY

The Jet 3 mid-wheel drive design provides superior performance and safety. The anti-tip wheels are an integral part of this design, because they provide stability during deceleration. The anti-tip wheels are preset at the factory to a height of 1.27 cm) 1/2-in. off the ground. This is the ideal setting for most Jet 3 users. However, you may encounter situations where you may need to adjust the anti-tip wheels. For instance, if you drive your Jet 3 on deep-pile carpeting or similar surfaces, you may notice that the anti-tip wheels have a tendency to drag on the carpet. In this case, you may need to raise the anti-tip wheels. If you drive your Jet 3 primarily on smooth surfaces, such as linoleum or tile, you may find that you are tipping forward a bit more than you find comfortable. (This may be particularly true for lighter users.) In this case, you may need to lower the anti-tip wheels.

i **NOTE:** Before making height or pre-load adjustments to your front anti-tip wheels, consult your authorised Pride dealer to make sure that your seat is properly positioned

3. Use a 13 mm spanner to loosen the locking nut.
4. Turn the bolt clockwise to raise the anti-tip wheel. Turn the bolt anticlockwise to lower the anti-tip wheel.
5. Tighten the locking nut.
6. Repeat for other anti-tip wheel.

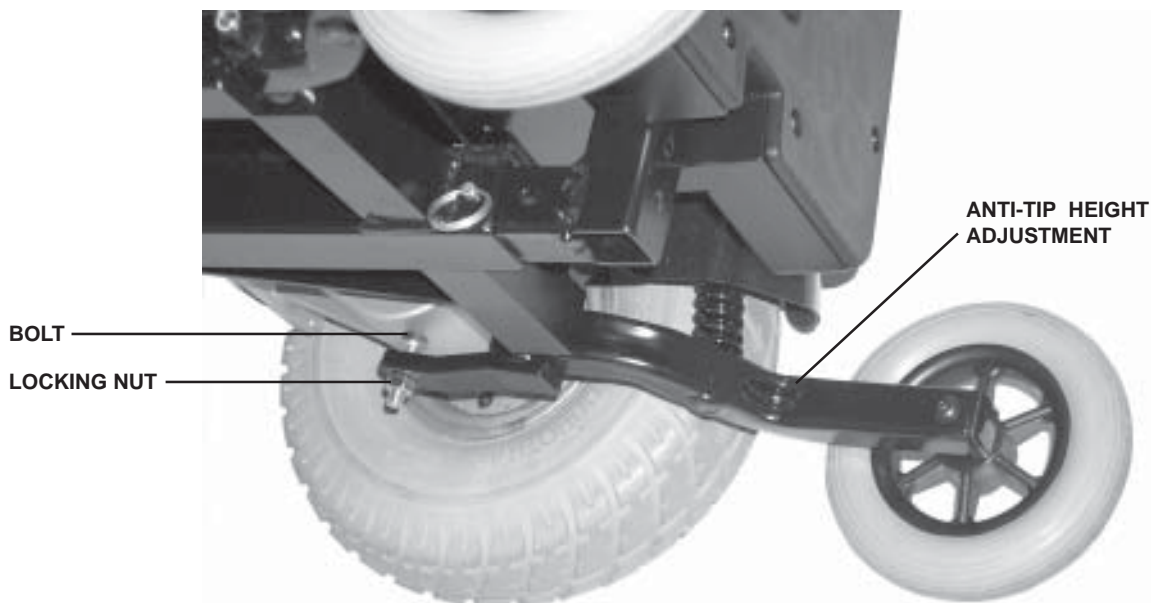

Figure 22. Anti-tip Wheel Height Adjustment

CASTOR WHEEL ASSEMBLY

Your power chair is equipped with two castor wheel assemblies. The castor wheel system works by allowing the castor forks to respond to weight transfers and uneven terrain. The castor wheels will pivot as you drive over obstacles. This system also enhances performance when the front anti-tip wheels are set lower to the surface.

Care and Maintenance

PREVENTIVE MAINTENANCE

Refer to the table below for a recommended maintenance schedule. If, after you perform the following periodic maintenance checks, you perceive that there is a problem with your power chair, contact your authorised Pride dealer.

JOYSTICK/CONTROLLER

Visually inspect the joystick. Make sure that it is not cracked or damaged and that it returns to center when you release it.

Periodic Maintenance Table					
Maintenance Check	Daily	Weekly	Monthly	Semi-annually	Yearly
Joystick/Controller	X				
Controller Harness and Charger Connections	X				
Controller Harness and Charger Condition		X			
Tyre Pressure		X			
Electromagnetic Brakes		X			
Anti-tip Wheels			X		
Castor Wheels			X		
Drive Wheel Tyres			X		
Motor Brushes				X	
Annual Check-up					X

CONTROLLER HARNESS CONNECTION

Inspect the controller harness. Make sure that it is not frayed or cut or that any of the wires are exposed.

CONTROLLER HARNESS CONDITION

Disconnect the controller and charger harnesses from the electrical connector housing. Inspect for corrosion. Ensure that all parts of the controller system are securely fastened to your power chair. Do not overtighten any screws.

ELECTROMAGNETIC BRAKES

Check the brakes. Refer to 'Electrical System.'

ANTI-TIP WHEELS

Check that the anti-tip wheels are not rubbing the ground when you are operating your power chair. If they are, contact your authorised Pride dealer to have them adjusted. Check for extreme wear on the anti-tip wheels. Replace them as necessary.

CASTOR WHEELS

Check the castor wheels for wear. Replace as necessary.

DRIVE WHEEL TYRES

Check for drive wheel tyre wear. If they are worn excessively, replace them. If one side is worn more than the other or if they appear to have worn unevenly, contact your authorised Pride dealer before replacing them.

MOTOR BRUSHES

Check the motor brushes. Refer to 'Electrical System.'

YEARLY CHECK-UP

Take your power chair to your authorised Pride dealer for yearly maintenance. This will help ensure that your power chair is functioning properly and help prevent future complications.

CLEANING

Your power chair has a clear-coated ABS-plastic body shroud that you may clean easily with a damp cloth. Never hose off your power chair or place it in direct contact with water. Never use any chemicals to clean a vinyl seat, as they may cause the seat to become slippery or dry out and crack. Use soapy water and dry the seat thoroughly.

HOW TO PREPARE YOUR POWER CHAIR FOR STORAGE

Fully charge the batteries and disconnect them from their wiring harnesses. If you plan to store your power chair for an extended period, block the unit up off of the ground with several boards under the frame. This will keep the tyres off of the ground and prevent the possibility of flat spots developing in the tyres.



CAUTION! Some of the parts of your Jet 3 are susceptible to extreme changes in temperature. Always keep your Jet 3 between the temperatures of -8°C/18°F and 50°C/122°F.

CORRECTIVE MAINTENANCE

Your controller is programmed to let you know if it detects a fault in one of the circuits. If the controller is suspected to be the cause of the problem, it will have to be checked using the programmer available only to authorised Pride dealer.

REPLACEMENT PARTS

Replacement parts are available from your authorised Pride dealer. Contact them for more information.

AUTHORISED PRIDE DEALER REPAIRS

If you feel that your power chair's performance has degraded or is not operating correctly, contact your authorised Pride dealer. All components should be serviced by an authorised Pride dealer while the unit is still under warranty. We do not recommend that you remove any parts and send them back for repair without first contacting your authorised Pride dealer.

Contact your authorised Pride dealer for a list of dealer service facilities or visit us at www.pridemobility.com. If there is a suspected malfunction or damage to your controller or the motors, contact your authorised Pride dealer immediately. They will advise you of the circumstances of repair.

Warranty

FIVE-YEAR LIMITED WARRANTY

Structural frame components including: platform, fork, seat posts, and frame welds.

TWO-YEAR WARRANTY

Drivetrain, including differential, motor, and brakes.

ONE-YEAR WARRANTY

Your Pride Power Chair is fully guaranteed for twelve (12) months from the date of purchase against faults arising due to defects in manufacture or materials. This warranty does not detract from, but is in addition to your legal rights.

All electronic parts including controllers, have a one (1) year warranty. Servicing to the controller or the battery chargers must be carried out by your authorised Pride dealer. Any attempt to open or dismantle these items renders the guarantee void on that item.

NOT COVERED UNDER WARRANTY

This warranty does not extend to those items which may need replacement due to wear and tear (tyres, belts, bulbs, upholstery, plastic shrouds, motor brushes, fuses, and batteries), or damage to the product caused by misuse or accident for which Pride or its agent cannot be held responsible. This warranty does not include labour or service calls.

BATTERIES

Batteries are covered by a twelve (12) month warranty from the original manufacturer.

Gradual deterioration in performance due to being left in a discharged state, left in cold conditions for long periods of time, or worn out through heavy use is not covered.

WARRANTY EXCLUSIONS

Warranty service can be performed by your authorised Pride dealer. Please contact your authorised Pride dealer for advice on the current cost affecting the service visit.

Notes

Notes

JET 3



Quality Control

Thank you for making the Jet 3 your choice in power chairs.

We have thoroughly inspected your Jet 3. The following checkmarks indicate that it has been driven and inspected

Model # _____

Serial # _____

Inclusion of all
Parts

Performance



Controller

Serial # _____

Fit and Finish

Pride keeps a more detailed report on file at the factory.

Date Inspected

Inspector