

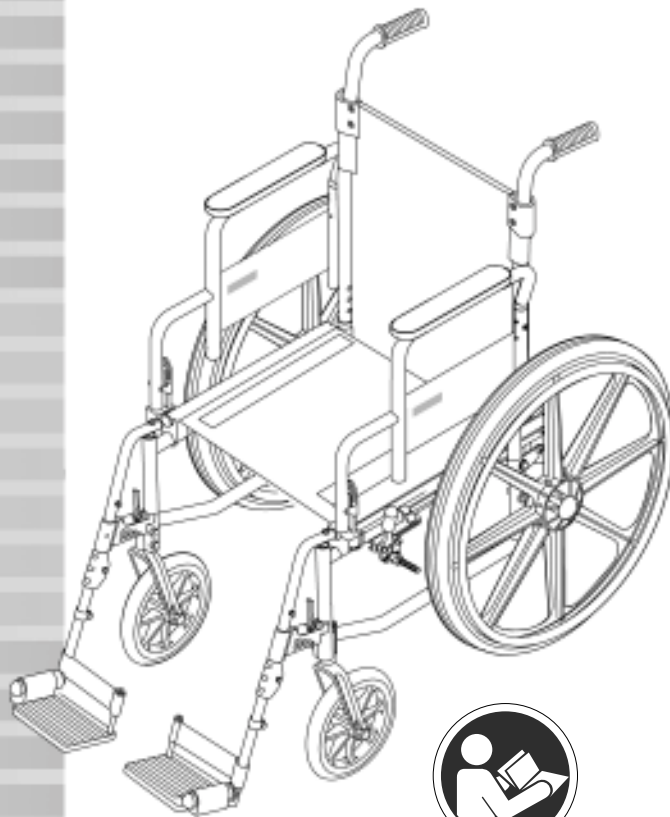

STYLUS 450
OWNER'S MANUAL



PRIDE MOBILITY PRODUCTS LTD.
UNIT 106, HEYFORD PARK CAMP ROAD
UPPER HEYFORD, OXFORDSHIRE OX25 5HA

Stylus

INFORMATION LABELING

Symbols are used throughout this owner's manual and on this product to convey important information regarding proper use, care, and maintenance.



WARNING! Failure to follow designated procedures can cause either personal injury, component damage, or malfunction (black symbol on yellow triangle with black border).



MANDATORY! These actions should be performed as specified. Failure to perform mandatory actions can cause injury to personnel and/or damage to equipment (white symbol on blue dot with white border).



PROHIBITED! These actions should be prohibited. These actions should not be performed at any time or in any circumstances. Performing a prohibited action can cause injury to personnel and/or damage to equipment (black symbol with red circle and red slash).



NOTE: Supplemental information that may be helpful to operate the equipment.

Symbols below are used on this product. Please read the information associated with each of the symbols presented and follow accordingly.



MANDATORY! Read and follow the information in the owner's manual.



MANDATORY! Maximum seating weight.



Copyright 2004
Pride Mobility Products Ltd.
INFMANU2734/Rev A/May04

TABLE OF CONTENTS

INFORMATION LABELING	2
SAFETY	4
PURCHASER'S AGREEMENT TO ENSURE SAFE OPERATION	4
CONTACT US	5
THE PRIDE STYLUS	6
WEIGHT CAPACITY	7
USING THE PRIDE STYLUS	8
UNFOLDING	8
FOLDING	8
TRANSPORTING YOUR PRIDE STYLUS	9
PRE-RIDE CHECKS	9
PREPARING YOUR WHEELCHAIR FOR TRANSFER	10
REACHING AND BENDING	11
TIPS FOR SAFE USE	12
PRIDE STYLUS ADJUSTMENTS	14
DRIVE WHEEL POSITION	14
SWING-AWAY FOOTREST (SFR) FOOT PLATE LENGTH	15
SEATBACK HEIGHT	16
SEAT ANGLE (DUMP)	16
CASTER ANGLE	17
MAINTENANCE	18
PREVENTIVE MAINTENANCE	18
CORRECTIVE MAINTENANCE	20
OPTIONAL ACCESSORIES	20
OXYGEN TANK HOLDER	20
ANTI-TIP WHEELS	20
WARRANTY	21

This owner's manual is compiled from the latest specifications and product information available at the time of publication. We reserve the right to make changes as they become necessary. Any changes to our products may cause slight variations between the illustrations and explanations in this manual and the product you have purchased.

SAFETY

WELCOME to Pride Mobility Products Ltd. (Pride). The product you have purchased combines state-of-the-art components with **safety**, comfort, and styling in mind. We are confident that these design features will provide you with the conveniences you expect during your daily activities. Once you understand how to **safely** operate and care for this product, it should give you years of trouble free operation and service.

Read and **follow** all instructions, warnings, and notes in this manual before attempting to operate this product for the first time. In addition, your **safety** depends upon you, as well as your dealer, caretaker, or healthcare professional in using good judgement.

If there is any information in this manual which you do not understand, or if you require additional assistance for setup or operation, please contact your authorised Pride Dealer. **Failure to follow the instructions in this manual and those located on your product can lead to personal injury and/or damage to the product, including voiding the warranty.**

PURCHASER'S AGREEMENT TO ENSURE SAFE OPERATION

By accepting delivery of this product, you promise that you will not change, alter, or modify this product or remove or render inoperable or unsafe any guards, shields, or other safety features of this product; fail, refuse, or neglect to install any retrofits kits from time to time provided by Pride to enhance or preserve the safe use of this product.

CONTACT US

We want to hear your questions, comments, and suggestions regarding this owner's manual and our products. We would also like to hear about the service you receive from your authorised Pride Dealer. Please feel free to contact us directly.

Pride Mobility Products Ltd.
Unit 106, Heyford Park Camp Road
Upper Heyford, Oxfordshire OX25 5HA
www.pridemobility.com

Please notify us if you change your address, so we can keep you apprised of important information regarding safety, new products, and new options that can increase your ability to use and enjoy this product.

Keep the following information on your Pride product. We need to know this when you contact us.

Authorised Pride Dealer: _____

Address: _____

Phone Number: _____ Purchase Date: _____

If you ever lose or misplace your product registration card or owner's manual, contact us and we will be glad to send you a new one immediately.

THE PRIDE STYLUS

The Pride Stylus is a dual-position, rear-wheel drive wheelchair designed to operate both indoors and outdoors on smooth surfaces.

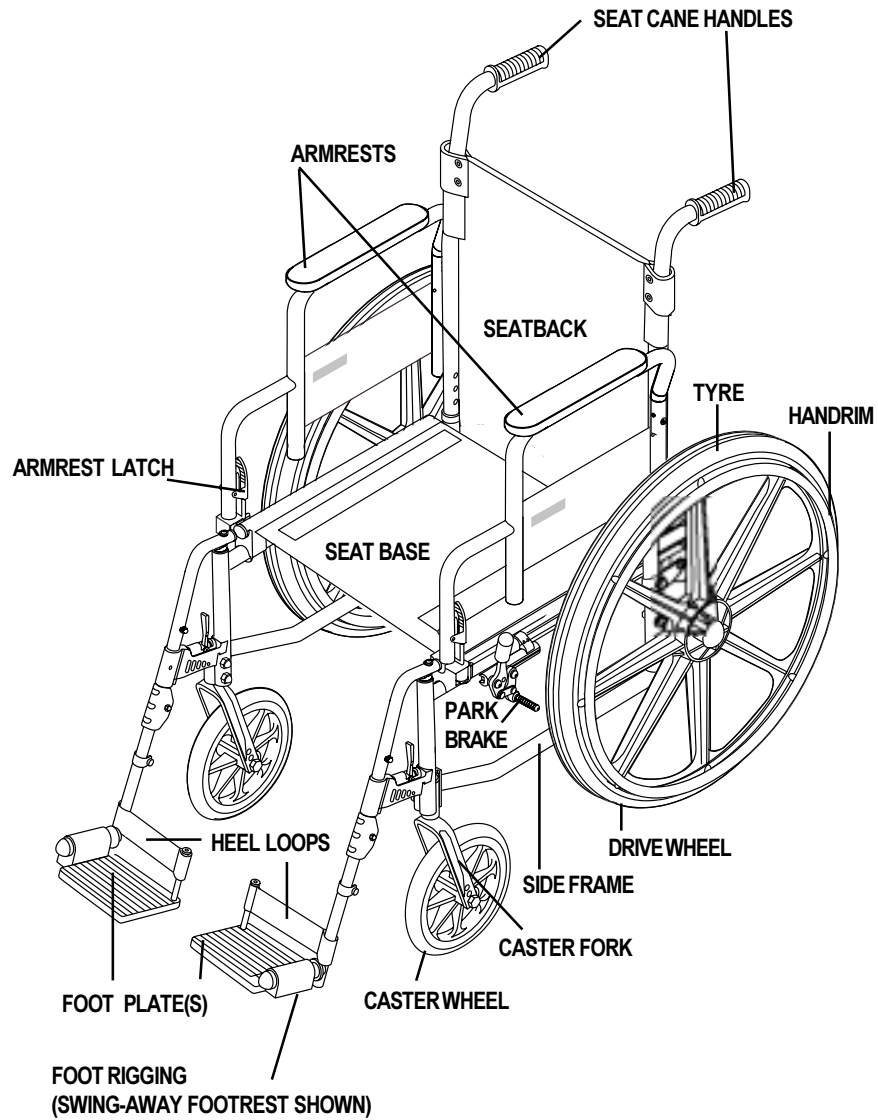

Figure 1. Pride Stylus

Pride Stylus Specifications Table	
Base Weight:	13 kg (29 lbs.) (<i>without foot riggings</i>) 15 kg (33 lbs.) (<i>with foot riggings</i>)
Seat Dimensions:	41 cm X 41 cm (16 in. X 16 in.) 46 cm X 41 cm (18 in. X 16 in.) 46 cm X 46 cm (18 in. X 18 in.) 51 cm X 41 cm (20 in. X 16 in.) 51 cm X 46 cm (20 in. X 18 in.)
Back Height:	38 cm — 43 cm (15 in. — 17 in.)
Seat-to-Floor Height:	Standard wheel: 47 cm — 49.5 cm (18.5 in. — 19.5 in.) adjustable Super-Hemi (SH) wheel: 39 cm (15.5 in.)
Seat Upholstery:	Adjustable tension
Drive Wheels:	61 cm (24 in.) Mag wheel with aluminum handrim and solid* tyre
Axle Mount:	2-position, Quick-release
Caster Wheels:	20 cm (8 in.) solid* tyre
Caster Fork:	4-position axle
Armrests:	Flip-back, desk-length
Foot Riggings:	70° swing-away, industry-compatible, through-bolted foot plate extension tubes, reinforced hanger brackets
Brakes:	Push-to-lock, adjustable
Frame Finish:	Silver Vein
Accessories:	Oxygen Tank Holder (<i>optional</i>) Anti-tip Wheels (<i>optional</i>)
Weight Capacity:	113.5 kg/250 lbs./17.86 stone

*polyurethane

WEIGHT CAPACITY

Refer to the Pride Stylus Specifications Table for the maximum weight capacity. Exceeding the maximum weight capacity may cause your wheelchair to become unstable and tip over. It is also likely to damage your wheelchair. Pride will not be responsible for injuries and/or property damage resulting from failure to observe weight limitations. Damage to your wheelchair caused by exceeding the weight limit is not covered by the warranty.

The following conditions increase the possibility of exceeding the weight limit:

- **Rear Flap** - The rear flap is for pocket items such as cell phones, keys, and papers. There are no other storage areas on your wheelchair. Carrying heavy baggage or tying heavy baggage to your wheelchair can make it unstable.
- **Multiple Riders** - Your wheelchair was designed to carry one person. Carrying more than one person will likely exceed the weight limit and cause your wheelchair to become unstable.

MODIFICATIONS

Under no circumstances should you modify, add, remove, or disable any feature, part, or function of your wheelchair unless under the direction of an authorised Pride Dealer.

USING THE PRIDE STYLUS

The Pride Stylus is a manual wheelchair. Either an attendant pushes it, or you move it by gripping the handrims and turning them in the desired direction of travel. You steer it by turning one wheel faster than the other. To stop the wheelchair, you apply pressure to both handrims until the wheelchair comes to a complete stop.

UNFOLDING

The Pride Stylus is a folding wheelchair. You must unfold it completely before sitting in it.

To unfold the Pride Stylus:

1. Engage both park brakes. See figure 2.
2. Flip up the seat canes and lock them into place.
3. Place the palm of your hands on each seat base rail. See figure 3.
4. Press down until the seat base rails are locked into place.

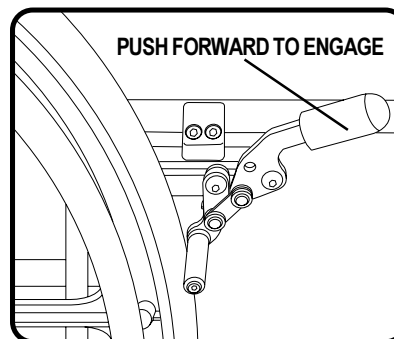

Figure 2. Right Park Brake Engaged

FOLDING

Folding the wheelchair makes it easier to carry and store. The folded width is 30 cm (11.75 in.).

To fold the Pride Stylus:

1. Engage both park brakes. See figure 2.
2. Push down on the seat cane release lever on each side to fold the canes down.
3. Grasp the seat base by the centre at the front and at the back. See figure 5.
4. Pull up on the seat base until both wheels close together.

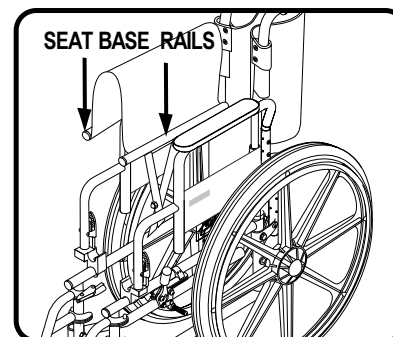

Figure 3. Unfolding the Pride Stylus

TRANSPORTING YOUR PRIDE STYLUS

Currently, there are no approved standards for tie-down systems used to secure your wheelchair to a moving vehicle of any type while you or anyone else is seated in the wheelchair. Although your wheelchair may be equipped with a positioning belt, this belt is not designed to provide proper restraint during motor vehicle transport. Anyone travelling in a motor vehicle should be properly secured in the motor vehicle seat with safety belts securely fastened. The Pride Stylus was designed to be folded and stored in a secure location such as in the boot of a car.

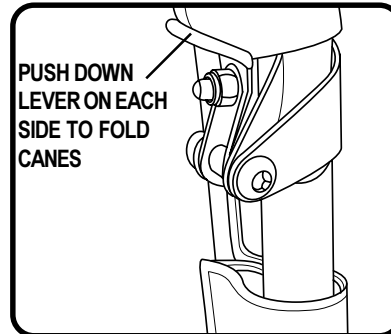

Figure 4. Seat Cane Release Lever

i **NOTE:** You can also remove the drive wheels to make the wheelchair more compact. See figure 14.

To lift or carry the Pride Stylus:

1. Fold the Pride Stylus.
2. With one hand, grab and squeeze together both seat cane handles. See figure 6.
3. With the other hand, grab and squeeze together both seat base rails.

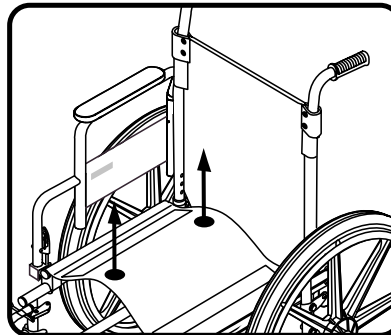

Figure 5. Folding the Pride Stylus

! **WARNING!** Prevent injury. If you remove the drive wheels, make sure the quick-release buttons snap into place when reinstalling a wheel. See figure 14.

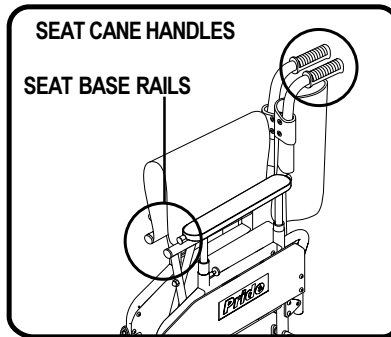

Figure 6. Lifting Points

PRE-RIDE CHECKS

Pride recommends that you practice using the wheelchair in the presence of a trained attendant. A trained attendant is a healthcare professional specifically trained to assist wheelchair users in various daily activities. Perform the following pre-ride checks before using your wheelchair to help ensure your wheelchair operates smoothly and safely:

- ✓ Check for loose or missing screws, nuts, and bolts. Replace or tighten them as necessary.

- ✓ Check the tyres. Look for uneven wear, holes, or tyre/wheel separation. If they look excessively worn, then have them replaced.
- ✓ Visually inspect pneumatic tyres for punctures. Confirm correct air pressure as marked on the side of the tyre. Always use a pressure-regulated air supply to inflate the tyres.
- ✓ Check the handrims. Make sure that they are fastened securely to the wheels.
- ✓ Check the park brakes. Make sure they work properly. If they don't, instructions on how to adjust them are provided in this manual.



WARNING! The park brakes are designed to keep your chair stationary while you are parked. They are not designed to stop the wheelchair during driving. Do not use either of the park brakes to stop the wheelchair while driving it. This can cause your wheelchair to become unstable and tip. Failure to heed can result in personal injury and/or damage to your wheelchair

- ✓ Check that your wheelchair drives straight and does not pull to one side. Pulling to one side could be an indication that a wheel bearing needs to be replaced.
- ✓ Check the caster wheels. Look for uneven wear, holes, or tyre/wheel separation. If they look excessively worn, then have them replaced. Make sure they swivel freely. If they don't, the swivel bearings may need to be replaced.
- ✓ Check the seat for sagging, rips, or tears.
- ✓ If your wheelchair is equipped with a positioning belt, make sure it is fastened securely to the wheelchair and there are no rips or tears.
- ✓ Check the anti-tip wheels (optional equipment). Make sure that they are attached securely.

If you discover a problem, contact your authorised Pride Dealer for assistance.

PREPARING YOUR WHEEL-CHAIR FOR TRANSFER

There are a variety of methods you can use to transfer onto or off of your wheelchair. Regardless of the method you use, transferring onto or off of your wheelchair safely requires practice and, in some cases, the presence of a certified healthcare professional or trained attendant. Make sure you have a certified healthcare professional or trained attendant present while learning to properly transfer yourself.

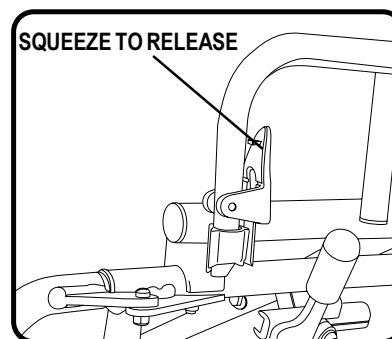

Figure 7. Flip-up Armrest Latch

To prepare your wheelchair for transfer:

1. Move the wheelchair as close as possible to you (or to your transfer destination).
2. Turn both caster wheels toward you (or toward your transfer destination) to improve wheelchair stability during transfer.
3. Make sure that both park brakes are engaged. See figure 2.
4. If necessary, flip up an armrest. See figure 7.

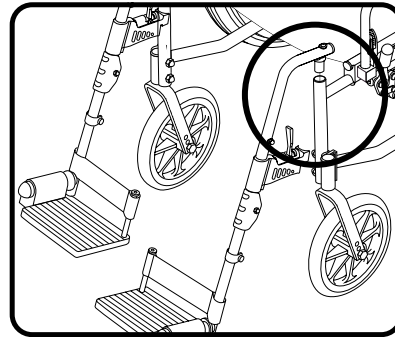

Figure 8. Foot Rigging Removal



WARNING! Reduce the risk of your wheelchair tipping. Do not use armrests to support yourself during transfer. Failure to heed can result in personal injury and/or damage to your wheelchair.

5. Either remove the foot riggings or move them aside. See figure 8. You can also flip up the foot plates. This will help to prevent your feet from being caught on the foot riggings during the transfer. If you use the foot riggings to support yourself during transfer, you risk tipping your wheelchair.

REACHING AND BENDING

Reaching and bending when seated in your wheelchair requires practice. Pride recommends that you determine your personal limitations, and practice bending and reaching in the presence of a certified healthcare professional or trained attendant. Keep the following in mind when reaching or bending:

- Come to a complete stop and engage the park brakes before attempting to reach or bend.
- When reaching, bending, or leaning while seated in your wheelchair, it is important that you maintain stability to keep the wheelchair from tipping.
- Reaching, bending, or leaning down to pick up objects between your knees may change your centre of gravity and the weight distribution of your wheelchair and cause your wheelchair to tip over.

TIPS FOR SAFE USE

The Pride Stylus was designed to be simple to use on smooth, level surfaces. However, you may encounter situations that require a higher level of skill. It is for these situations that you will benefit from practicing with a trained attendant. Pride performs extensive testing on our wheelchairs. From the results of these tests, we have determined that the following conditions are outside the normal operating range of the Pride Stylus and require the presence of a certified health-care professional or trained attendant.

PERFORMING “WHEELIES”

Performing “wheelies” (lifting the caster wheels off the ground to travel over an object) requires skill, balance, and hours of practice in the presence of a trained attendant. If you attempt to perform a “wheelie” and do not have the skill to do so alone, you risk tipping over rearward. Do not perform “wheelies” unless you are skilled enough to do so.

CLIMBING INCLINES

The maximum incline angle your wheelchair can climb safely on solid ground is 8.7% at maximum weight capacity. See figure 9. Most handicap access ramps are pitched at 8.7%. Any attempt to climb a steeper incline may put your wheelchair in an unstable position, especially if the incline is rough or uneven terrain.

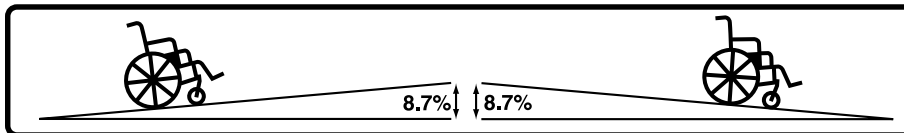

Figure 9. Maximum Safe Incline Angle (Ascending and Descending)

KERBS AND OTHER OBSTACLES

Pride recommends driving around kerbs or other obstacles, rather than over them. However, there may be some situations where it may be necessary to climb a kerb. If you are going to attempt to climb onto a kerb, approach it slow and straightforward. See figures 10 and 11.

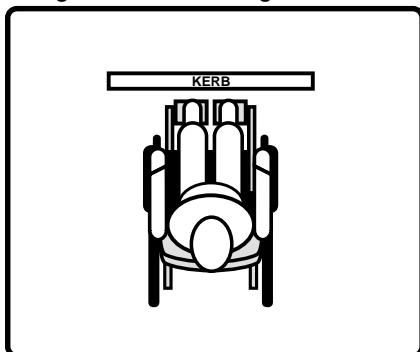

Figure 10. Incorrect Kerb Approach

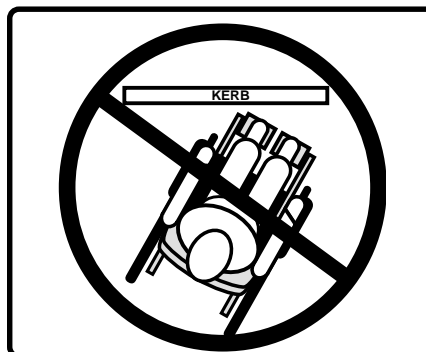

Figure 11. Correct Kerb Approach

STAIRS AND LIFTS

Most multilevel buildings that have stairs and escalators also have lifts. Pride recommends that you use the lift to move to a different level. Under no circumstances should you use escalators. If you must use steps, then we recommend that you seek assistance. Do not attempt to have your wheelchair proceed rearward down any step, kerb, or other obstacle. This may cause the wheelchair to tip and cause personal injury.

CORNERING

Always exercise common sense when cornering. If the situation arises where you have to negotiate a sharp corner, reduce your speed and lessen the sharpness of the turn. This greatly reduces the possibility of a tip or fall.

Other factors which affect the possibility of tipping include, but are not limited to:

- cornering speed
- steering angle (how sharply you are turning)
- cornering on uneven road surfaces
- cornering on inclined road surfaces
- cornering on a surface that has different types of traction (such as passing from a grassy area to a paved area, especially at high speed while turning)
- making abrupt directional changes

OFF-ROAD

Pride does not recommend that you use your wheelchair on anything other than solid, smooth surfaces. Driving your chair on uneven surfaces can cause your wheelchair to become unstable and tip over.

STREETS AND ROADWAYS

Consult your local laws concerning the use of your wheelchair on public streets and roadways. Be aware that it may be difficult for traffic to see you. When crossing public streets or roadways, wait until your path is clear of traffic and then proceed with extreme caution. Always obey all local pedestrian traffic rules.

MEDICATIONS

Some medications may impair your ability to drive your wheelchair in a safe manner. Consult your physician if you are taking prescribed or over-the-counter medication. This includes alcohol. Your prescription may impair your ability to operate your wheelchair in a safe manner.

INCLEMENT WEATHER

Although your wheelchair was designed for outdoor use, we do not recommend that you use it outdoors during inclement weather. Driving your wheelchair in the rain or snow or on icy surfaces increases the risk of an accident.

PRIDE STYLUS ADJUSTMENTS

You must have your Pride Stylus set up by your authorised Pride Dealer prior to initial use. If you make adjustments to the Pride Stylus without proper guidance, you can change your centre of gravity and cause the wheelchair to become unstable under certain conditions (such as stopping, cornering, etc.). There are several adjustments that can be made to the Pride Stylus:

- Drive Wheel Position
- Swing-away (SFR) Footrest Length
- Seatback Height
- Seat Angle (Dump)
- Park Brake
- Seat Tension

TOOLS REQUIRED FOR ADJUSTMENT

Adjustments to your wheelchair can be made using the following:

- Metric sockets
- Metric hex keys
- Adjustable spanner

DRIVE WHEEL POSITION

Each drive wheel is attached to the frame by a bracket. The position of this bracket on the frame changes the drive wheel position. See figures 12 and 13. When the bracket is in positions A or C, the seat-to-floor height is 49.5 cm (19.5 in.). When the bracket is in positions B or D, the seat-to-floor height is 47 cm (18.5 in.). Drive wheel bracket position also affects performance and centre of gravity. Positions A and B move the drive wheel rearward. Positions C and D move the drive wheel forward.

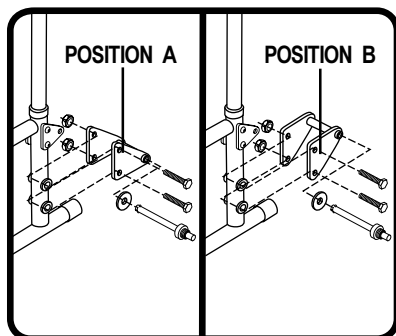

Figure 12. Drive Wheel Bracket

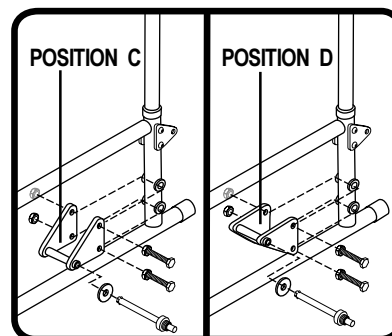

Figure 13. Drive Wheel Bracket

i **NOTE:** If you change the drive wheel position, you may have to shorten the foot plate length, change the caster height, and adjust the park brake. Consult your authorised Pride Dealer. Also refer to the Seat-to-Floor Height Matrix.

To change the drive wheel position:

1. Press the quick-release button and pull the drive wheel off. See figure 14.
2. Remove the hardware that fastens the drive wheel bracket to the frame.
3. Reposition the drive wheel bracket (either position A, B, C, or D).
4. Reinstall the hardware that fastens the drive wheel bracket to the frame.
5. Reinstall the drive wheel. Make sure that the wheel axle is snapped securely into the drive wheel bracket.
6. Repeat for the other drive wheel.

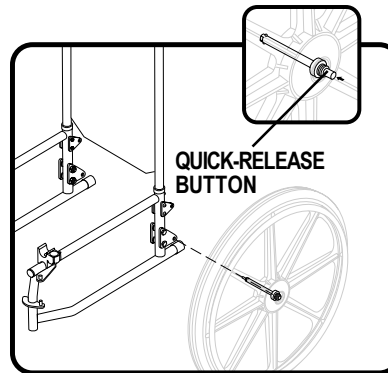

Figure 14. Drive Wheel Quick Release

i **NOTE:** When using an oxygen tank holder, the drive wheel bracket must be in either position A or B.

Seat-to-Floor Height Matrix		
S-T-F Height	Caster Position	Drive Wheel Position
49.5 cm (19.5 in.)	20 cm (8 in.) (second hole from bottom)	61 cm (24 in.)(position A or C)
47 cm (18.5 in.)	15 cm (6 in.) (second hole from bottom)	56 cm (22 in.)(position A or C)
47 cm (18.5 in.)	20 cm (8 in.) (top hole)	61 cm (24 in.)(position B or D)
44.5 cm (17.5 in.)	20 cm (8 in.) (top hole)	56 cm (22 in.)(position A or C)
47 cm (18.5 in.)	15 cm (6 in.) (second hole from bottom)	61 cm (24 in.)(position B or D)
44.5 cm (17.5 in.)	15 cm (6 in.) (top hole)	56 cm (22 in.)(position B or D)
39 cm (15.5 in.) (SH)*	13 cm (5 in.) (top hole)	51 cm (20 in.)(position A or C)

* Super Hemi

**SWING-AWAY FOOTREST (SFR)
FOOT PLATE LENGTH**

You can change the SFR foot plate length between 30 – 43 cm (12 – 17 in.) in 2.5 cm (1 in.) increments. This length is measured from the SFR foot plate to the top of the SFR. See figure 15.

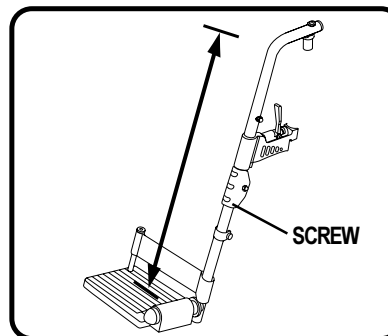

Figure 15. SFR Foot Plate Adjustment

To change the SFR foot plate length:

1. Remove the screw from the SFR.
2. Adjust the foot plate to the desired length.
3. Reinstall the screw into the SFR.
4. Repeat for the other side.

SEATBACK HEIGHT

You can adjust the seatback to one of three different heights. The adjustment range is 7.5 cm (3 in.) in 2.5 cm (1 in.) increments. See figure 16.

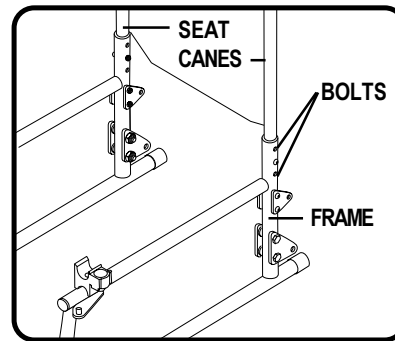

Figure 16. Seatback Height Adjustment

To adjust the seatback height:

1. Remove the bolts to unfasten the seat canes from each side of the frame.
2. Slide the canes up or down into one of the three holes for the desired height.
3. Use the bolts to refasten the seat canes into the frame.

SEAT ANGLE (DUMP)

The position of the caster wheels affects the angle of the seat (dump). There are four holes in the caster fork. By changing the location of the caster wheel on the fork, you change the seat angle. See figure 17.

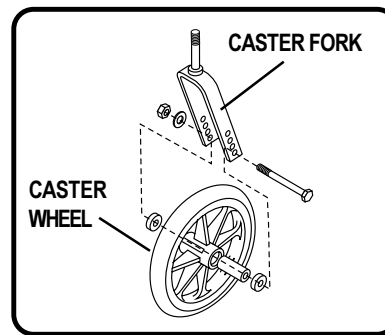

Figure 17. Caster Wheel Position



NOTE: You can also adjust the seat angle by raising or lowering the drive wheel. See “Drive Wheel Position.”

To change the seat angle:

1. Remove the hardware that fastens the caster wheel to the caster fork.
2. Reposition the caster wheel on the caster fork.
3. Reinstall the hardware that fastens the caster wheel to the caster fork.
4. Repeat the procedure for the other side.



WARNING! Changing the seat angle may adversely affect stability and cause the wheelchair to tip over. Failure to heed this warning can result in personal injury and/or damage to your wheelchair.

CASTER ANGLE

When you change the seat angle, you must also change the caster angle so that the caster wheels remain at a 90° angle to the ground. There are three possible caster angles. See figure 18. If the front of the seat is higher than the rear, the caster wheel assembly should be in position 1. If there is little or no seat dump (i.e., the seat is parallel to the ground), the caster wheel assembly should be in position 2. If the rear of the seat is higher than the front, the caster wheel assembly should be in position 3.

i **NOTE:** There are two bolts that fasten the caster wheel assembly to the frame. The bolt shafts are offset to the bolt heads. The bolt shafts must be positioned either fore or aft relative to the holes.

To change the caster angle:

1. Remove the bolts that fasten the caster wheel assembly to the frame.
2. Reposition the bolts according to the table below.
3. Tighten the bolts.

Caster Position	Top Bolt Position	Bottom Bolt Position	Caster Wheel Angle
1	Fore	Aft	95°
2	Fore	Fore	90°
3	Aft	Fore	85°

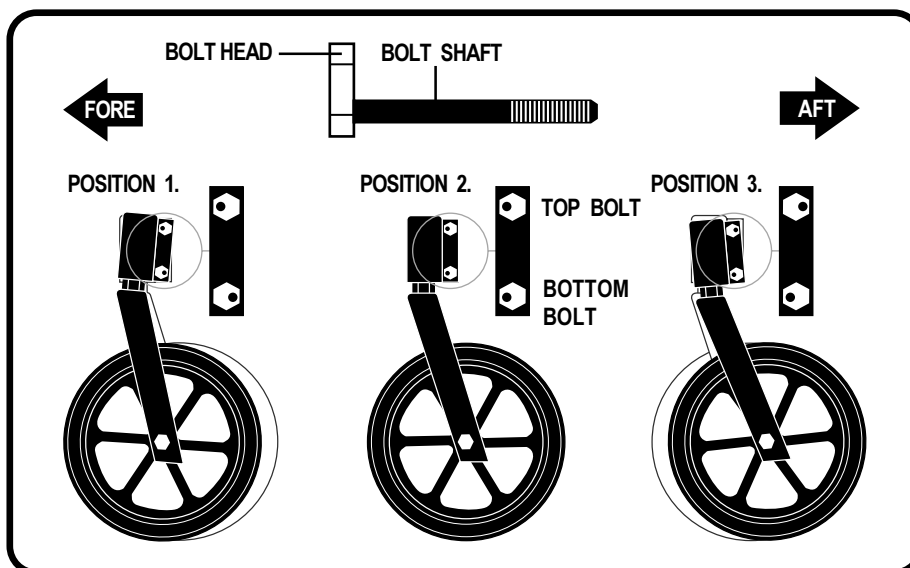

Figure 18. Caster Angle Adjustment

MAINTENANCE

Maintenance is an important part of wheelchair ownership. There are two types of maintenance: preventive (routine) and corrective. Preventive maintenance enables you to help extend the life of your wheelchair by catching potential problems before it becomes necessary to correct them. Corrective maintenance is what you must do when your wheelchair needs immediate repair.

PREVENTIVE MAINTENANCE

In addition to your pre-ride checks, you can pay particular attention to your drive wheels and the overall appearance of your wheelchair. Keep your wheelchair clean. This will help prevent dirt and other contaminants from getting into places where it doesn't belong, like the drive wheel bearings, the frame hinges, or the caster bearings. Drive wheel and caster bearings are sealed and do not require lubrication.

DRIVE WHEELS AND CASTER WHEELS

Worn tyres can make your wheelchair difficult to drive. Check for drive tyre and caster tyre wear. If they are worn excessively, then replace them. If they appear to have worn unevenly, then contact your authorised Pride Dealer before replacing them. Pneumatic tyre tubes may be either patched or replaced. Though patching pneumatic tyre tubes is a viable method of repair, we recommend replacing the pneumatic tyre tube. We also recommend using a regulated air source. This will decrease the likelihood of overinflating the tyre and causing it to burst.



NOTE: Although you can remove the tube from the tyre without first removing the drive wheel, we recommend removing the drive wheel first.

To replace a pneumatic tyre tube:

1. Remove the drive wheel from the frame. See figure 14.
2. Make sure that the tube is deflated completely.
3. Use several tyre levers to pry the tyre from the wheel. Tyre levers are available from a bicycle shop.
4. Remove the old tube.
5. Inflate the new tube with enough air so that it just starts to take shape, about **10 psi/.69 bar**.
6. Insert the tube into the tyre.
7. Use the tyre levers to secure the tyre back onto the wheel.
8. Inflate the tyre to the pressure recommended on the sidewall. Always use a regulated air source.
9. Reinstall the drive wheel to the frame. Make sure that the wheel axle is snapped securely into the drive wheel bracket.

PARK BRAKES

After several months of use, you may find it necessary to adjust the park brakes so that they lock securely when engaged. You also may need to adjust them after changing the drive wheel position.



WARNING! If your wheelchair is equipped with pneumatic tyres, make sure they are inflated to the pressure recommended on the sidewall of the tyre. Failure to heed can result in personal injury and/or damage to your wheelchair.

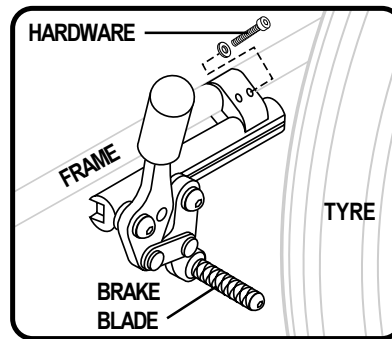

Figure 19. Park Brake Adjustment

To adjust each park brake:

1. Engage the park brake. See figure 2. The distance that the park brake blade should travel into the tyre is 31 mm (1/8 in.) for pneumatic tyres and 63 mm (1/4 in.) for solid tyres.
2. Disengage the park brake.
3. Loosen the hardware that fastens the park brake to the frame. See figure 19.
4. Reposition the park brake.
5. Tighten the hardware that fastens the park brake to the frame.
6. Reengage the park brake and note the position of the blade.
7. Reposition the park brake if necessary.
8. Repeat the procedure for the other side.

CASTER WHEEL SWIVEL

Caster wheels that have difficulty swiveling may indicate that the bearings need to be changed. If they are not swiveling freely, contact your authorised Pride Dealer immediately.

SEAT TENSION

After a period of use, you may find it necessary to adjust the seat tension.

To adjust the seat tension:

1. Loosen the screws that attach the seat to the side rail on the left side (side with hook and loop). See figure 20.
2. Unfasten the hook and loop.
3. Grab the bottom flap and pull the seat tight.
4. Fasten the hook and loop.
5. Tighten the screws. Make sure that the plastic washers are on top of the fabric.

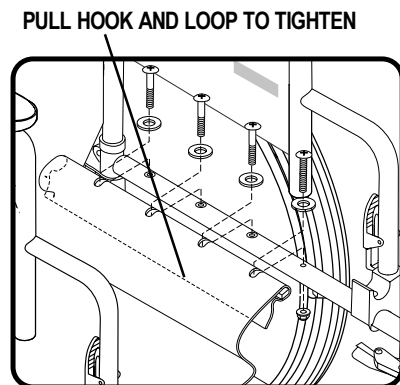

Figure 20. Seat Tension Adjustment

CLEANING

To keep your wheelchair clean, use a damp cloth and wipe it down. Don't use a hose. This could force moisture into the caster swivel or the drive wheel hub. Always use soapy water on the seat and dry it thoroughly before using.

CORRECTIVE MAINTENANCE

If you feel that your wheelchair's performance has degraded or is not operating correctly, contact your authorised Pride Dealer. All components should be serviced by an authorised Pride Dealer while the unit is still under warranty. We do not recommend that you remove any parts and send them back for repair without first contacting your authorised Pride Dealer. Contact your authorised Pride Dealer for a list of authorised service facilities or you can visit us at www.pridemobility.com.

REPLACEMENT PARTS

Replacement parts are available from your authorised Pride Dealer.

OPTIONAL ACCESSORIES

Installation instructions for optional accessories are provided with the accessory.

OXYGEN TANK HOLDER

The oxygen tank holder mounts to the back of the wheelchair and is capable of carrying a 4.5 kg (10 lb.) tank. The anti-tip wheels must be used with the oxygen tank. Refer to the instructions that accompany the oxygen tank holder.



MANDATORY! Install anti-tip wheels when the oxygen tank holder is installed.

ANTI-TIP WHEELS

Anti-tip wheels are available for the Pride Stylus.

WARRANTY

Pride warrants this product, so far as the same is of its own manufacture, to be free of defects in material and workmanship, when used by the purchaser under normal conditions, for (1) year after purchase. The side frames and cross-frames are warranted for the life of the product to the original purchaser.

The warranties herein specified shall not apply if the failure of any component of this product to satisfy such warranty is due to accident, neglect, misuse, improper transportation arranged by the purchaser or its agent, or causes other than ordinary use including operation contrary to Pride's operating instructions or if any person other than Pride's authorised personnel shall modify, adjust, or repair such product or perform any related service on it.

It must be understood that the purchaser assumes full responsibility for the overall safe operation in the environment for which the product is intended to function.

NOTES



Quality Control - Stylus

Thank you for making the Stylus your choice in wheelchairs.

We have thoroughly inspected your Stylus. The following checkmarks indicate that it has been test driven and inspected.

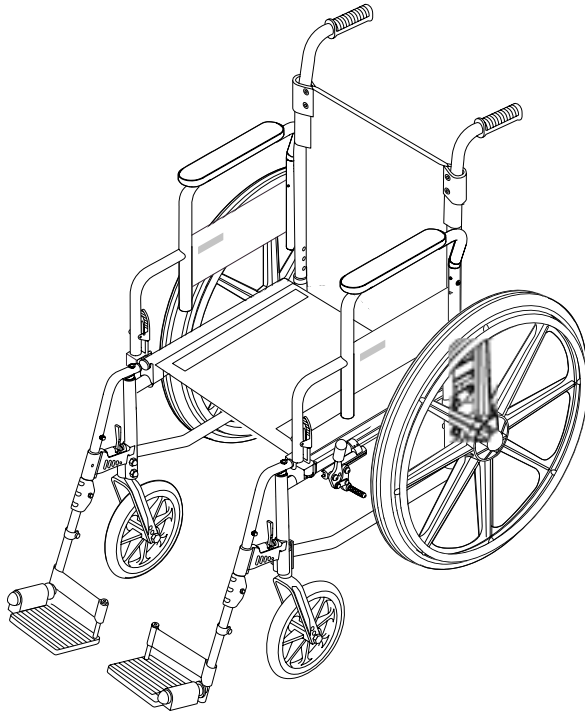

- Inclusion of all Parts
- Performance
- Fit and Finish

Date Inspected _____

Inspector _____

Serial # _____

Pride keeps a more detailed report on file at the factory.