

Hurricane

Owner's Manual



The Ultimate In Style & Performance[®]

Pride
Mobility Products Ltd.

*Unit 106 Heyford Park Camp Road
Upper Heyford Oxfordshire OX25 5HA*

www.pridemobility.com

SAFETY GUIDELINES

Please read and follow all instructions in this owner's manual before attempting to operate your scooter for the first time. If there is anything in this manual you do not understand, or if you require additional assistance for set-up, contact your authorised Pride provider.

Using your Pride product safely depends upon your diligence in following the warnings, cautions, and instructions in this owner's manual. Using your Pride product safely also depends upon your own good judgement and/or common sense, as well as that of your provider, caregiver, and/or healthcare professional. Pride is not responsible for injuries and/or damage resulting from any person's failure to follow the warnings, cautions, and instructions in this owner's manual. Pride is not responsible for injuries and/or damage resulting from any person's failure to exercise good judgement and/or common sense.

The symbols below are used throughout this owner's manual to identify warnings and cautions. It is very important for you to read and understand them completely.



WARNING! Failure to heed the warnings in this owner's manual may result in personal injury.



CAUTION! Failure to heed the cautions in this owner's manual may result in damage to your scooter.

C O N T E N T S

I. INTRODUCTION	4
II. SAFETY	6
III. SPECIFICATIONS	15
IV. YOUR HURRICANE	17
V. BATTERIES AND CHARGING	24
VI. OPERATION	28
VII. COMFORT ADJUSTMENTS	30
VIII. DISASSEMBLY AND ASSEMBLY	33
IX. OPTIONAL ACCESSORIES	36
X. BASIC TROUBLESHOOTING	37
XI. CARE AND MAINTENANCE	39
XII. WARRANTY	41

I. INTRODUCTION

Welcome to Pride Mobility Products Ltd. (Pride). Congratulations on the purchase of your new Pride scooter. Your scooter design combines the most advanced state-of-the-art components with modern, attractive styling. We are certain that the design features and trouble-free operation will add convenience to your daily living and ensure complete satisfaction.

At Pride, your safety is important to us. **Please read and follow all of the instructions in this manual before you attempt to operate your Hurricane for the first time.** These instructions were produced for your benefit. Your understanding of these instructions is essential for the safe operation of your new Pride Hurricane.

Pride is not liable for damage to property or personal injury arising out of unsafe use of a Pride scooter. Pride is also not liable for any property damage or personal injury arising out of the failure of any person and/or user to follow the instructions and recommendations set forth in this manual or any other instructions or recommendations contained in other Hurricane related literature issued by Pride or contained on the Pride Scooter itself.

This owner's manual is compiled from the latest specifications and product information available at the time of publication. We reserve the right to make changes as they become necessary. Any changes to our products may cause slight variations between the illustrations and explanations in this manual and the product you have purchased.

If you experience any problems with your Hurricane that you are unable to solve, or if you do not feel capable of safely following any of the instructions and/or recommendations as contained in this manual, please contact your authorised Pride provider for assistance.

Once you understand how to operate and take care of your Hurricane, we are certain that it will give you years of trouble-free service and enjoyment.

Information Exchange

We want to hear your questions, comments, and suggestions about this manual. We would also like to hear about the safety and reliability of your new Pride Scooter and the service you received from your authorised Pride provider.

Please notify us of any change of address so we can keep you apprised of important information about safety, new products, and new options that can increase your ability to use and enjoy your Pride Scooter. Please feel free to write us at the address below:

Pride Mobility Products Ltd.
Unit 106, Heyford Park Camp Road
Upper Heyford, Oxfordshire, OX25 5HA

I. INTRODUCTION

My Authorised Pride Provider Is:

Name: _____

Address: _____

Phone Number: _____

Quick Reference Information:

Model: _____

Serial Number: _____

Purchase Date: _____

NOTE: If you ever lose or misplace your warranty card or your copy of this manual, e-mail or write to us and we will be glad to send you a new one immediately.

II. SAFETY

GENERAL



WARNING! Do not operate your new Hurricane for the first time without completely reading and understanding this owner's manual.

Your Hurricane is a state-of-the-art life-enhancement device designed to increase mobility. Pride provides an extensive variety of products to best fit the individual needs of the Hurricane user. Please be aware that the final selection and purchasing decision regarding the type of Hurricane to be used is the responsibility of the Hurricane user who is capable of making such a decision and his/her healthcare professional (i.e., medical doctor, physical therapist, etc.).

The contents of this manual are based on the expectation that a mobility device expert has properly fitted the Hurricane to the user and has assisted the prescribing healthcare professional and/or the authorised Pride provider in the instruction process for the use of the product.

There are certain situations, including some medical conditions, where the Hurricane user will need to practice operating the Hurricane in the presence of a trained attendant. A trained attendant can be defined as a family member or care professional specially trained in assisting a Hurricane user in various daily living activities.

As you begin using your Hurricane during daily activities, you will probably encounter situations in which you will need some practice. Simply take your time and you will soon be in full and confident control as you maneuver through doorways, on and off elevators, up and down ramps, and over moderate terrain.

Below are some precautions, tips, and other safety considerations that will help the user become accustomed to operating the Hurricane safely.

MODIFICATIONS

Pride has designed and engineered your Hurricane to provide maximum mobility and utility. A wide range of accessories is available from your Pride provider to further customize your Hurricane to better suit your needs and/or preferences. However, under no circumstances should you modify, add, remove, or disable any feature, part, or function of your Hurricane.



WARNING! Do not modify your Hurricane in any way not authorised by Pride. Unauthorised modifications may result in personal injury and/or damage to your Hurricane.

II. SAFETY

PRE-RIDE SAFETY CHECK

Get to know the feel of your Hurricane and its capabilities. Pride recommends that you perform a safety check before each use to make sure your Hurricane operates smoothly and safely. For details on how to perform these necessary inspections, see XI. “Care and Maintenance.”

Perform the following inspections prior to using your Hurricane:

- Check for proper tyre inflation. Maintain **30-35 psi** in each tyre (if equipped with pneumatic tyres).
- Check all electrical connections. Make sure they are tight and not corroded.
- Check all controller connections to the electronics module. Make sure they are secured properly.
- Check the brakes.
- Check battery charge.



WARNING! It is critically important that 30-35 psi tyre pressure be maintained in pneumatic tyres at all times. Failure to maintain 30-35 psi tyre pressure in pneumatic tyres at all times may result in catastrophic tyre and/or wheel failure, causing serious personal injury and/or damage to your Hurricane.

WARNING! Do not carry passengers on your Hurricane. Carrying passengers on your Hurricane may result in personal injury and/or property damage.

If you discover a problem, contact your authorised Pride provider for assistance.

WEIGHT LIMITATIONS

Your scooter is rated for a maximum 181 kg, (400 lb.) weight limit.



WARNING! Exceeding the weight limit voids your warranty and may result in personal injury and damage to your Hurricane. Pride will not be held responsible for injuries and/or property damage resulting from failure to observe weight limitations.

INCLINE INFORMATION

More and more buildings have ramps with specified degrees of inclination, designed for easy and safe access. Some ramps may have turning switchbacks (180-degree turns) that require you to have good cornering skills on your Hurricane.

- Proceed with extreme caution as you approach the downgrade of a ramp or other incline.
- Take wide swings with your Hurricane’s front wheels around any tight corners. If you do that, the Hurricane’s rear wheels will follow a wide arc, not cut the corner short, and not bump into or get hung up on any railing corners.
- When driving down a ramp, keep the Hurricane’s speed adjustment set to the slowest speed setting to ensure a safely controlled descent. See IV. “Your Hurricane.”
- Avoid sudden stops and starts.

II. SAFETY

When climbing an incline, try to keep your Hurricane moving. If you must stop, start up again slowly, and then accelerate cautiously. When driving down an incline, do so by setting the speed adjustment button to the slowest setting and driving in the forward direction only. If your Hurricane starts to move down the incline faster than you anticipated or desired, allow it to come to a complete stop by releasing the throttle control lever. Then push the throttle control lever forward slightly to ensure a safely controlled descent.

WARNING! When climbing an incline, do not zigzag or drive at an angle up the face of the incline. Drive your Hurricane straight up the incline. This greatly reduces the possibility of a tip or a fall. Always exercise extreme caution when negotiating an incline.



WARNING! You should not travel up or down a potentially hazardous incline (i.e., areas covered with snow, ice, cut grass, or wet leaves).

WARNING! When on any sort of an incline or decline, never place the Hurricane in freewheel mode while seated on it or standing next to it.

Handicap public access ramps are not subject to government regulation in all countries, and therefore do not necessarily share the same standard percent of slope. Other inclines may be natural or, if man-made, not designed specifically for scooters. Figure 1 illustrates your scooter's stability and its ability to climb grades under various weight loads and under controlled testing conditions.

These tests were conducted with the Hurricane's seat in the highest position and adjusted rearward on the seat base to its farthest rearward position. Use this information as a guideline. Your Hurricane's ability to travel up inclines is affected by your weight, your Hurricane's speed, your angle of approach to the incline, and your Hurricane's setup.

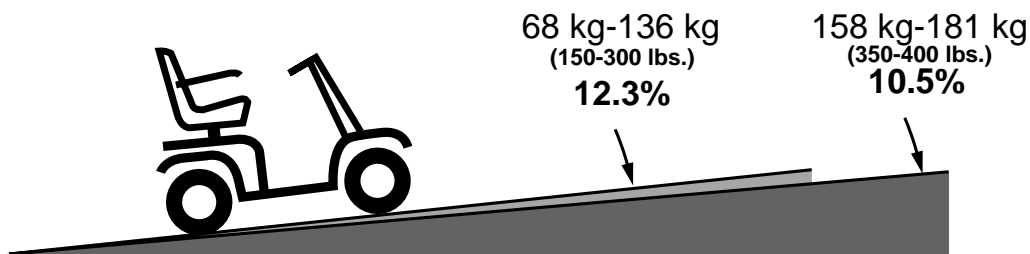

FIGURE 1. MAXIMUM RECOMMENDED INCLINE ANGLES



WARNING! Any attempt to climb or descend a slope steeper than that shown in figure 1 may put your Hurricane in an unstable position and cause it to tip, resulting in personal injury.

II. SAFETY

When you approach an incline, it is best to lean forward. See figures 2 and 3. This shifts the center of gravity of you and your Hurricane toward the front of the Hurricane for improved stability.



WARNING! Do not exceed the incline guidelines or any other specifications presented in this manual.



FIGURE 2. NORMAL DRIVING POSITION

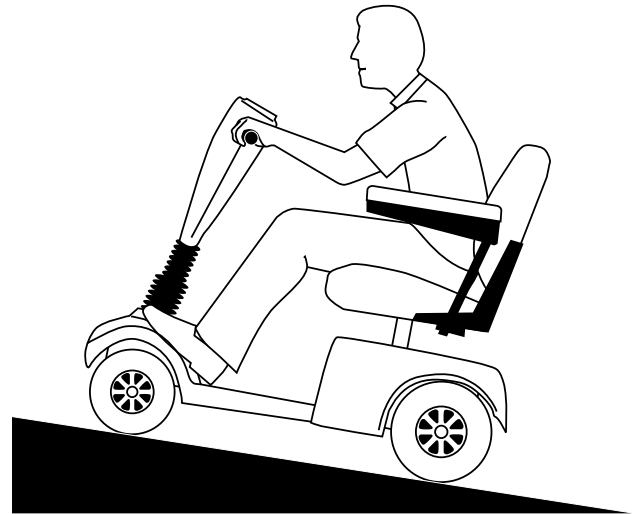

FIGURE 3. INCREASED STABILITY DRIVING POSITION

CORNERING INFORMATION

Excessively high cornering speeds can create the possibility of tipping. Factors which affect the possibility of tipping include, but are not limited to, cornering speed, steering angle (how sharply you are turning), uneven road surfaces, inclined road surfaces, riding from an area of low traction to an area of high traction (such as passing from a grassy area to a paved area – especially at high speed while turning), and abrupt directional changes. High cornering speeds are not recommended. If you feel that you may tip over in a corner, reduce your speed and steering angle (i.e., lessen the sharpness of the turn) to prevent your Hurricane from tipping.



WARNING! When cornering sharply, reduce your speed. When using your Hurricane at higher speeds, do not corner sharply. This greatly reduces the possibility of a tip or fall. To avoid personal injury or property damage, always exercise common sense when cornering.

II. SAFETY

BRAKING INFORMATION

Your Hurricane is equipped with two powerful brake systems:

1. Regenerative: Uses electricity to rapidly slow the vehicle when the throttle control lever returns to the center/stop position.
2. Disc Park Brake: Activates mechanically after regenerative braking slows the vehicle to near stop, or when power is removed from the system for any reason.

OUTDOOR DRIVING SURFACES

Your Hurricane is designed to provide optimum stability under normal driving conditions—dry, level surfaces composed of concrete, blacktop, or asphalt. However, Pride recognizes that there will be times when you will encounter other surface types. For this reason, your Hurricane is designed to perform admirably on packed soil, grass, and gravel. Feel free to use your Hurricane safely on lawns and in park areas.

- Reduce your Hurricane's speed when driving on uneven terrain and/or soft surfaces.
- Avoid tall grass that can become tangled in the running gear.
- Avoid loosely packed gravel and sand.
- If you feel unsure about a driving surface, avoid that surface.

STATIONARY OBSTACLES (STEPS, KERBS, ETC.)

Proceed with extreme caution when driving near raised surfaces, unprotected ledges, and/or drop-offs (kerbs, porches, stairs, etc.).



WARNING! Do not attempt to have your Hurricane climb or descend an obstacle that is inordinately high. Serious personal injury and/or damage may result.

WARNING! Do not attempt to have your Hurricane proceed rearwards down any step, kerb, or other obstacle. This may cause the Hurricane to tip and cause personal injury.

II. SAFETY

PUBLIC STREETS AND ROADWAYS



WARNING! You should not operate your Hurricane on public streets and roadways. Be aware that it may be difficult for traffic to see you when you are seated on your Hurricane. Obey all local pedestrian traffic rules. Wait until your path is clear of traffic, and then proceed with extreme caution.

NOTE: Safety accessories like reflectors, fluorescent flags, and various lighting packages are available to order from your authorised Pride provider.

INCLEMENT WEATHER PRECAUTIONS



WARNING! Pride recommends that you do not operate your Hurricane in icy or slippery conditions or on salted surfaces (i.e., walks or roads). Such use may result in an accident, personal injury, or adversely affect the performance and safety of your Hurricane.

WARNING! Pride recommends that you do not expose your Hurricane to any type of moisture at any time (rain, snow, mist, or wash). Such exposure can damage your Hurricane. Never operate your Hurricane if it has been exposed to moisture until it has dried thoroughly.

FREEWHEEL MODE

Your Hurricane is equipped with a manual freewheel lever that when pulled up allows the Hurricane to be pushed. For more information about how to place your Hurricane into and out of freewheel mode, See IV. "Your Hurricane."



WARNING! Do not use your Hurricane in freewheel mode without an attendant present. Personal injury may result.

WARNING! Do not attempt to personally place your Hurricane in freewheel mode while seated on it. Personal injury may result. Ask an attendant for assistance if necessary.

WARNING! Do not place your Hurricane in freewheel mode while on an incline. The Hurricane could roll uncontrollably on its own, causing personal injury.

TYRE INFLATION

If your Hurricane is equipped with pneumatic tyres, you should check or have the air pressure checked at least once a week. Proper inflation pressures will prolong the life of your tyres and help ensure the smooth operation of your Hurricane.



WARNING! It is critically important that pneumatic tyres be inflated to 30-35 psi. Do not underinflate or overinflate your tyres. Improper tyre pressure may result in catastrophic tyre and/or wheel failure. Serious personal injury and/or property damage may result.

WARNING! Inflate your Hurricane drive tyres from a regulated air source with an available pressure gauge. Minimum air pressure for Hurricane drive tyres is 30-35 psi. Inflating your tyres from an unregulated air source could overinflate them, resulting in a burst tyre and/or personal injury.

II. SAFETY

STAIRS AND ESCALATORS

Hurricanes are not designed to travel up or down stairs or escalators. Always use an elevator.



WARNING! Do not use your Hurricane to negotiate steps or escalators. You may cause injury to yourself and to others and damage your Hurricane.

DOORS

- Determine if the door opens toward or away from you.
- Use your hand to turn the knob or push the handle or push-bar.
- Drive your Hurricane gently and slowly forward to push the door open. Or drive your Hurricane gently and slowly rearwards to pull the door open.

ELEVATORS

Modern elevators have a door edge safety mechanism that, when pushed, reopens the elevator door(s).

- If you are in the doorway of an elevator when the door(s) begin to close, push on the rubber door edge or allow the rubber door edge to contact the Hurricane and the door will reopen.
- Use care that pocketbooks, packages, or Hurricane accessories do not become caught in elevator doors.

LIFT/ELEVATION PRODUCTS

If you will be traveling with your Hurricane, you may find it necessary to use a lift/elevation product to aid in transportation. Pride recommends that you closely review the instructions, specifications, and safety information set forth by the manufacturer of the lift/elevation product before using that product.

BATTERIES

In addition to following the warnings below, be sure to comply with all other battery handling information. For more information about your Hurricane's batteries, see V. "Batteries and Charging."



WARNING! 32 AH batteries weigh 11 kg (25 lbs.) each, and 40 AH batteries weight 15 kg (32.5 lbs.) each. If you are unable to lift that much weight, be sure to get help. Lifting beyond your capacity can result in personal injury.

WARNING! Battery posts, terminals, and related accessories contain lead and lead compounds. Wash hands after handling.

WARNING! Always protect the batteries from freezing and never charge a frozen battery. Charging a frozen battery may result in personal injury and/or damage to the battery.

PREVENTING UNINTENDED MOVEMENT



WARNING! If you anticipate being seated in a stationary position for an extended period of time, turn off the power. This will prevent unexpected motion from inadvertent throttle control lever contact. Failure to do so may result in personal injury.

II. SAFETY

MOTOR VEHICLE TRANSPORT

Currently, there are no standards approved for tie-down systems in a moving vehicle of any type to transport a person while seated in a Hurricane.

Although your Hurricane may be equipped with a positioning belt, this belt is not designed to provide proper restraint during motor vehicle transport. Anyone traveling in a motor vehicle should be properly secured in the motor vehicle seat with safety belts fastened securely.



WARNING! Do not sit on your Hurricane while it is in a moving vehicle. Personal injury and/or property damage may result.

WARNING! Always be sure your Hurricane and its batteries are properly secured when it is being transported. Failure to do so may result in personal injury and/or damage to your Hurricane.

GETTING ONTO AND OFF OF YOUR HURRICANE

Getting onto and off of your Hurricane requires a good sense of balance. Please observe the following safety tips when getting onto and off of your Hurricane:

- Power down your Hurricane. See VI. “Operation.”
- Ensure that your Hurricane is not in freewheel mode. See IV. “Your Hurricane.”
- Make certain that the seat is locked into place and the key is removed from the key switch.
- The seat armrests can be flipped up to make getting on and off the Hurricane easier.



WARNING! Position yourself as far back as possible in the Hurricane seat to prevent the Hurricane from tipping and causing injury.

WARNING! Avoid using your armrests for weight bearing purposes. Such use may cause the Hurricane to tip and cause personal injury.

WARNING! Avoid putting all of your weight on the floorboard. Such use may cause the Hurricane to tip and cause personal injury.

POSITIONING BELTS

Your authorised Pride provider, therapist(s), and other healthcare professionals are responsible for determining your requirement for a positioning belt in order to operate your Hurricane safely.



WARNING! If you require a positioning belt to safely operate your Hurricane, make sure it is fastened securely. Serious personal injury may result if you fall from the Hurricane.

II. SAFETY

REACHING AND BENDING

Avoid reaching or bending while driving your Hurricane. When reaching, bending, or leaning while seated on your Hurricane, it is important to maintain a stable center of gravity and keep the Hurricane from tipping. Pride recommends that the Hurricane user determine his/her personal limitations and practice bending and reaching in the presence of a qualified healthcare professional.



WARNING! Do not bend, lean, or reach for objects if you have to pick them up from the floor by reaching down between your knees. Movements such as these may change your center of gravity and the weight distribution of the Hurricane and cause your Hurricane to tip, possibly resulting in personal injury. Keep your hands away from the tyres when driving.

PRESCRIPTION DRUGS/PHYSICAL LIMITATIONS

The Hurricane user must exercise care and common sense when operating his/her Hurricane. This includes awareness of safety issues when taking prescribed or over-the-counter drugs or when the user has specific physical limitations.



WARNING! Consult your physician if you are taking prescribed or over-the-counter medication or if you have certain physical limitations. Some medications and limitations may impair your ability to operate your Hurricane in a safe manner.

ALCOHOL

The Hurricane user must exercise care and common sense when operating his/her Hurricane. This includes awareness of safety issues while under the influence of alcohol.



WARNING! Do not operate your Hurricane while you are under the influence of alcohol, as this may impair your ability to drive safely.

REMOVABLE PARTS



WARNING! Do not attempt to lift or move a Hurricane by any of its removable parts. Personal injury and damage to the Hurricane may result.

III. SPECIFICATIONS

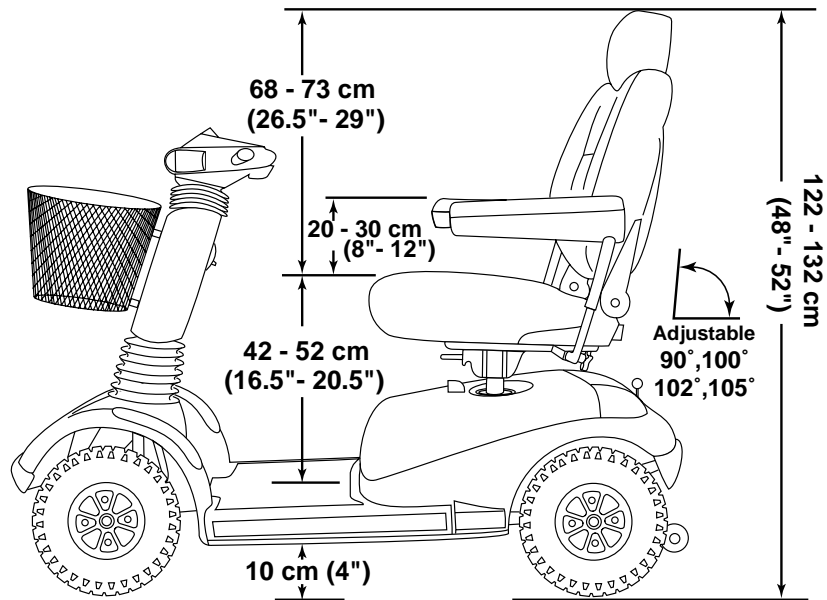
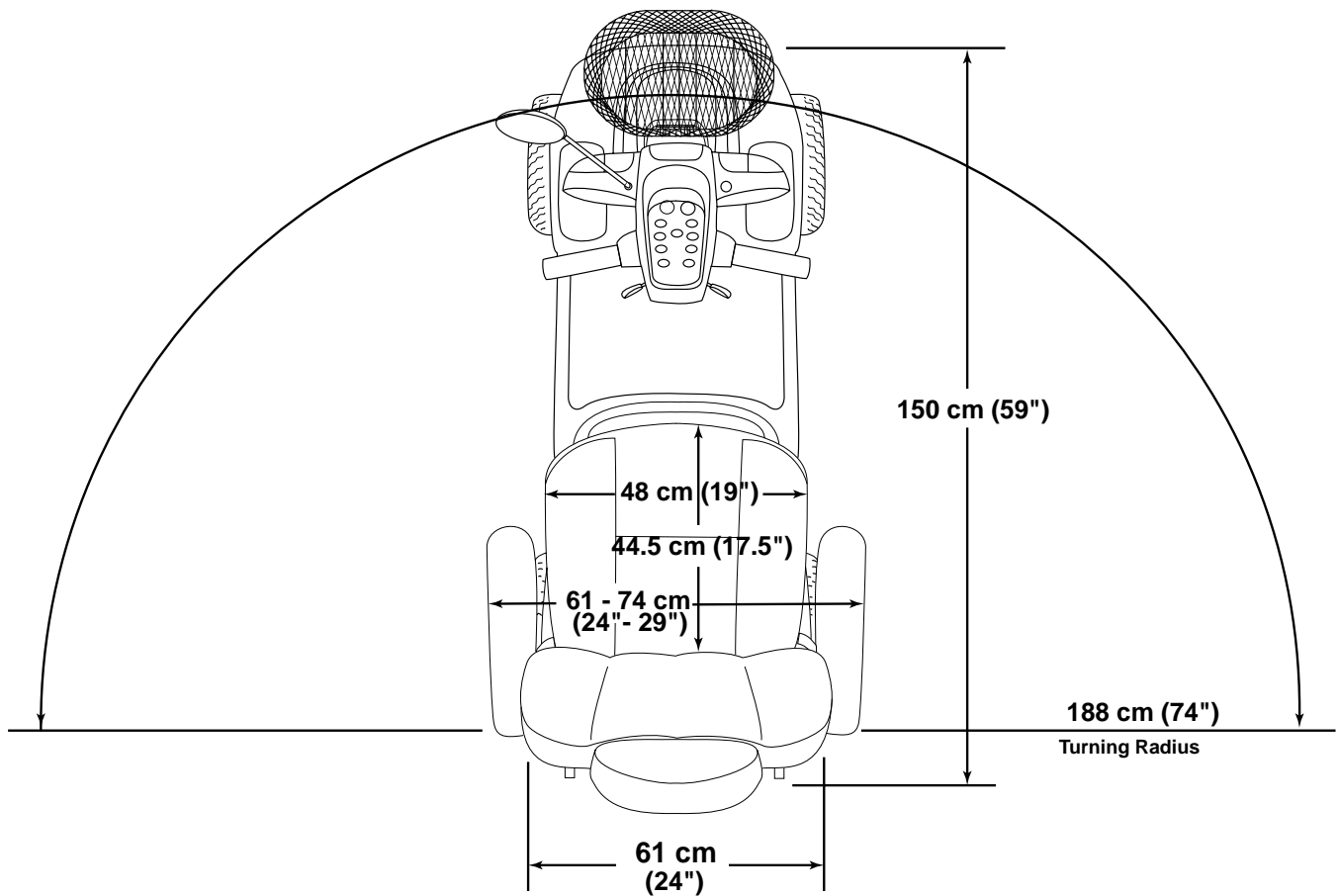

FIGURE 4. HURRICANE DIMENSIONS



III. SPECIFICATIONS

Model Number(s)	SCUK4500												
Length	150 cm (59 in.)												
Width	61 cm (26 in.)												
Tyres	Pneumatic; front: 10 cm x 33 cm (4 in. x 13 in.), rear: 10 cm x 33 cm (4 in. x 13 in.)												
Weight Capacity	181 kg, (400 lbs.) maximum												
Battery Type	Two 12 volt, 32 AH, U-1 type, SLA (sealed lead-acid) or two 12V, 40 AH, SLA												
Horsepower	1.4 hp (peak)												
Charger	Onboard 3-amp charger												
Speed	Variable up to 6.5 or 13 km/h (4 or 8 mph)												
Maximum Grade	Variable (refer to figure 1)												
Range, Maximum	(12V, 40 AH batteries) Up to 32 – 44 km (20-30 miles) (12V, 32 AH batteries) Up to 32 – 40 km (20-25 miles)												
Turning Radius	188 cm (74 in.)												
Body Colours	Painted: Candy Apple Red, Viper Blue, Forest Green, and Onyx Black												
Seating	<p>Standard option seating style: Sport Scooter high back with headrest and sliders mounted on a standard seat post</p> <p>Standard seating features:</p> <ul style="list-style-type: none"> • Adjustable armrest height, width, and angle • Four adjustable seatback angles • Five position seat height adjustment <p>Dimensions: 48 cm (19 in.) width x 44.5 cm (17.5 in.) depth (usable) x 47 cm (18.5 in.) height (usable)</p> <p>Material: Vinyl: Gray, Beige, Black Fabric: Gray, Gold</p> <p>Armrests: Upholstered, matching vinyl or fabric with cosmetic edge guards</p> <p>Adjustable seatpost height from ground: variable between 63.5 - 71 cm (25 - 28 in.)</p>												
Included Features	Full directional lighting package with front "running lights"; deluxe motorcycle-style rearview mirror (can be installed on left or right side of tiller); lighted touch pad control console; front basket; user adjustable sliding seat; full "soft-ride" shock absorber-equipped suspension; adjustable armrest width, height & angle; dual microprocessor-based motor controller system; modular controller/charger assembly; infinitely adjustable tiller with auto-leveling console; standard front & rear integrated bumpers; easily accessible charger port receptacle, circuit breaker and manual freewheel lever; standard non-marring, high density polyurethane bumper(s); battery well accepts 32 AH, 40 AH batteries; standard battery fixation strap; status LED; Hercules 3000 docking device												
Brakes	Electronic disc, manual freewheel												
Rear Wheel Drive	Sealed Transaxle - 24V												
Wheels	Aluminum alloy wheels in Black												
Tiller Type	Infinitely adjustable with auto-leveling console												
Freewheel Mechanism Availability	Lever at lower right portion of rear shroud												
Weight of Scooter	<p>Total weight of Hurricane (with two 12V, 40 AH batteries) = 122.5 kg (270 lbs.) Total weight of Hurricane (with two 12V, 32 AH batteries) = 115.5 kg (255 lbs.)</p> <p>Component breakdown:</p> <table> <tr> <td>Front section:</td> <td>37 kg (82.0 lbs.)</td> </tr> <tr> <td>Rear section (without batteries or rear shroud):</td> <td>34 kg (75.0 lbs.)</td> </tr> <tr> <td>Rear plastic shroud:</td> <td>2 kg (4.0 lbs.)</td> </tr> <tr> <td>Seat (high back with sliders):</td> <td>20 kg (44.0 lbs.)</td> </tr> <tr> <td>Batteries (two batteries are required per scooter):</td> <td>12V, 40 AH: 15 kg (32.5 lbs.) (each) 12V, 32 AH: 11 kg (25.0 lbs.) (each)</td> </tr> <tr> <td>Basket:</td> <td>.68 kg (1.5 lbs.)</td> </tr> </table>	Front section:	37 kg (82.0 lbs.)	Rear section (without batteries or rear shroud):	34 kg (75.0 lbs.)	Rear plastic shroud:	2 kg (4.0 lbs.)	Seat (high back with sliders):	20 kg (44.0 lbs.)	Batteries (two batteries are required per scooter):	12V, 40 AH: 15 kg (32.5 lbs.) (each) 12V, 32 AH: 11 kg (25.0 lbs.) (each)	Basket:	.68 kg (1.5 lbs.)
Front section:	37 kg (82.0 lbs.)												
Rear section (without batteries or rear shroud):	34 kg (75.0 lbs.)												
Rear plastic shroud:	2 kg (4.0 lbs.)												
Seat (high back with sliders):	20 kg (44.0 lbs.)												
Batteries (two batteries are required per scooter):	12V, 40 AH: 15 kg (32.5 lbs.) (each) 12V, 32 AH: 11 kg (25.0 lbs.) (each)												
Basket:	.68 kg (1.5 lbs.)												
Front-to-Rear Lockup	Dual lock pins & camlock levers												
Ground Clearance	10 cm (4 in.)												
Accessories	Rear basket; cup holder; safety flag; solid foam filled tyres; dust cover; weather breaker canopy												

IV. YOUR HURRICANE

Your Hurricane is a motorized electric scooter designed to enhance your personal mobility. Your Hurricane is an indoor/outdoor scooter designed to travel primarily on smooth surfaces, such as pavement, roads, parking lots, floors, and driveways. For easy transportation or storage, you can disassemble your Hurricane into seven components. See figure 5.



FIGURE 5. HURRICANE COMPONENTS

CONTROL CONSOLE ASSEMBLY

The control console assembly houses all of the controls you need to drive your Hurricane, including the speed adjustment dial, throttle control levers, battery condition meter, status LED, running lights button, horn buttons, turn signal buttons, and the hazard light button. See figure 6.



WARNING! Do not expose the control console assembly to moisture. In the event that the console does become exposed to moisture, do not attempt to operate your Hurricane until the console has thoroughly dried.

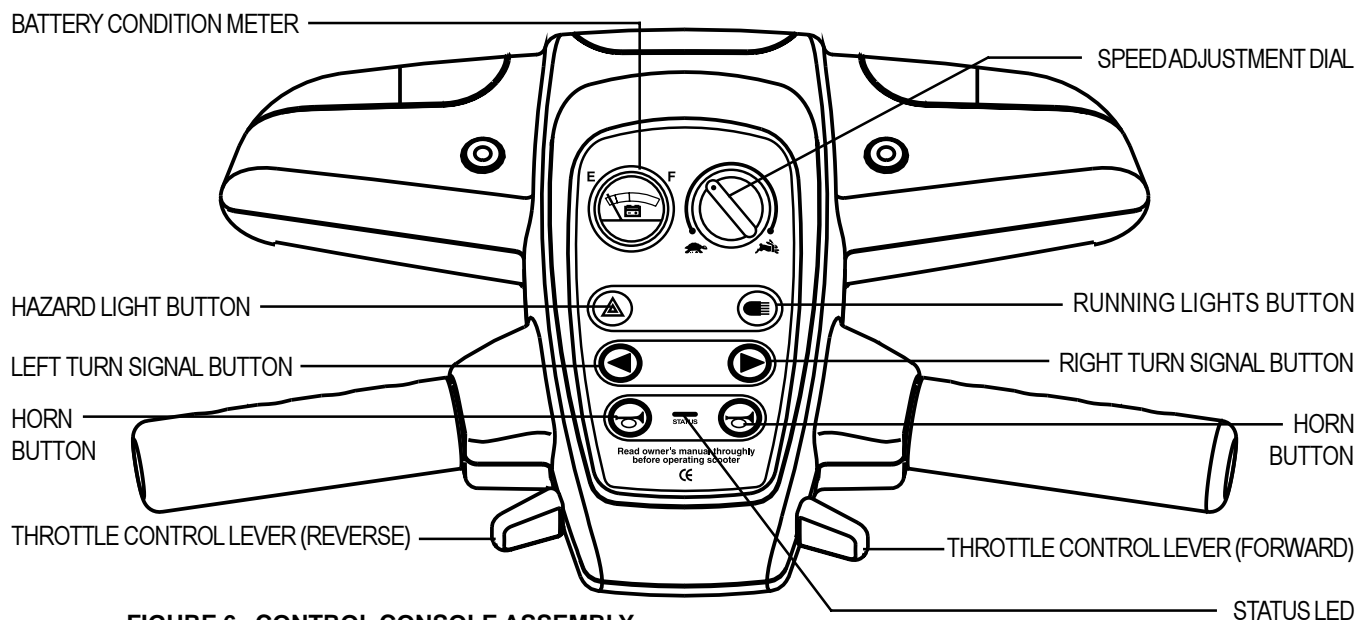

FIGURE 6. CONTROL CONSOLE ASSEMBLY

IV. YOUR HURRICANE

Key Switch

- Fully insert the key into the key switch and turn it clockwise to power up (turn on) your Hurricane.
- Turn the key counterclockwise to power down (turn off) your Hurricane.



WARNING! If the key is moved to the off position while your Hurricane is in motion, the electronic brakes engage and your Hurricane comes to an abrupt stop!

Speed Adjustment Dial

This control dial allows you to preselect and limit your scooter's top speed.

- The image of the tortoise represents the slowest speed setting.
- The image of the hare represents the fastest speed setting.

Throttle Control Lever

This lever allows you to control the forward speed and the reverse speed of your Hurricane up to the maximum speed you preset with the speed adjustment dial.

- Place your right hand on the right handgrip and your left hand on the left handgrip.
- Use your right thumb to push the right side of the lever to disengage your Hurricane's brakes and move forward.
- Release the lever and allow your Hurricane to come to a complete stop before pushing the other side of the lever to move in reverse.
- When the throttle is completely released, it automatically returns to the center "stop" position and engages your Hurricane's brakes.

Battery Condition Meter

This meter gives an approximate reading of your scooter's battery voltage when the key is fully inserted into the key switch.

- Green indicates the Hurricane's batteries are fully charged.
- Yellow indicates that the Hurricane's battery voltage level is getting low and will require a charge soon.
- Red indicates that your Hurricane's battery voltage level is very low, and the batteries should be recharged as soon as possible.

Running Lights Button

This button controls your Hurricane's running lights.

- Press the button once to turn on your Hurricane's running lights.
- Press the button again to turn off your Hurricane's running lights.

Horn Button

The key must be inserted and turned to the "on" position for the horn to be operational.

- This button activates a warning horn.
- Do not hesitate to use the warning horn when its use could prevent accident or injury.

Hazard Light Button

This button activates the 4-way flashers on your Scooter.

- Press the button once to turn on the flashers.
- Press the button again to turn off the flashers.

IV. YOUR HURRICANE

Turn Signal Buttons

- Press the appropriate turn signal button once to activate it.
- Your Hurricane's turn signals are timed to shut off automatically.

Status LED

The Status LED will alert you to electrical problems that may occur with the Hurricane. The LED remains constantly lit while your scooter is on. If the Hurricane develops an electrical problem, the status LED will flash a code. See XI. "Basic Troubleshooting"). If the status LED flashes a code other than a code listed in "Basic Troubleshooting", contact your authorised Pride Provider.

IV. YOUR HURRICANE

TILLER

Your Hurricane is equipped with an ergonomically enhanced pivoting tiller. This infinitely adjustable tiller is where the following components are located: the key, key switch, 6.5 - 13 km/h (4-8 mph) switch, and the tiller adjustment lever. See figure 6A.

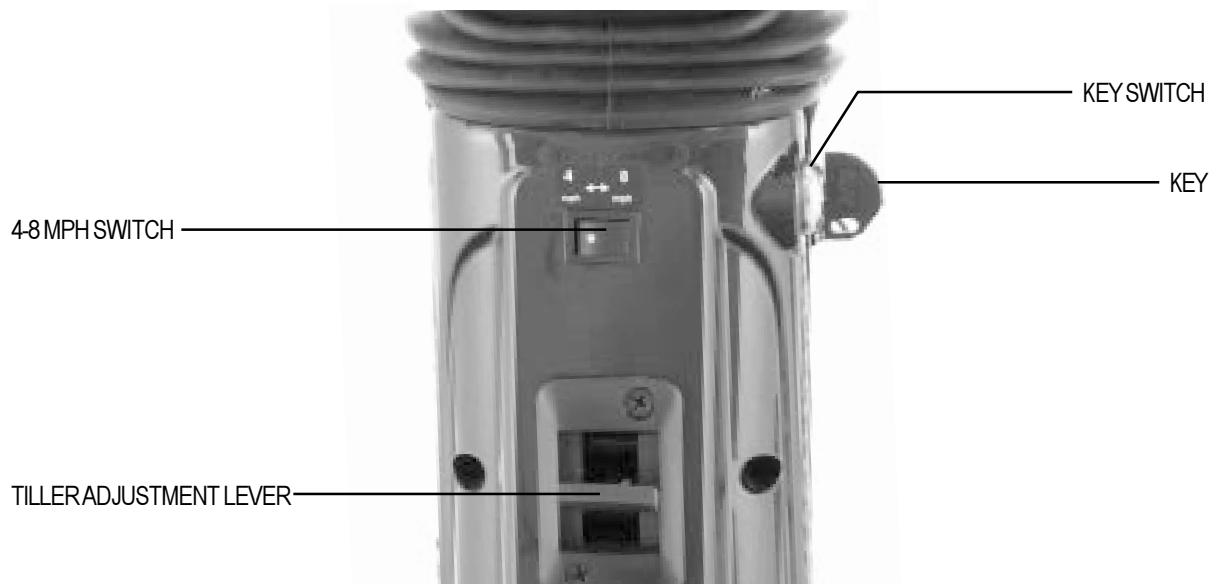

FIGURE 6A. TILLER

Tiller Adjustment Lever

This lever allows you to adjust the tiller to a number of positions between the forward stop and the Hurricane deck. See figure 6A.

- Pull up on the tiller adjustment lever to move the tiller to a comfortable position.
- Release the tiller adjustment lever and the tiller remains in that position.

Key Switch

To turn the Hurricane on, fully insert the key and turn it clockwise. To turn the Hurricane off, turn the key counterclockwise. See figure 6A.

4 mph - 8 mph Switch

This switch limits the Hurricane's top speed to either 6.5 or 13 km/h (4 or 8 mph) depending on where the Hurricane's preset maximum speed is set. See figure 6A.

- With the switch set to 6.5 km/h (4 mph), the Hurricane's top speed is 6.5 km/h (4 mph).
- With the switch set to 13 km/h (8 mph), the Hurricane's top speed is 13 km/h (8 mph).

When driving indoors, keep the 6.5-13 km/h (4-8 mph) switch set to 6.5 km/h (4 mph).

IV. YOUR HURRICANE

REAR SECTION

The onboard battery charger (not shown), the charger power lead receptacle, the batteries (not shown), the electronics module, the main circuit breaker (reset button), the ammeter, the manual freewheel lever, the anti-tip wheels, and the motor/transaxle assembly (not shown) are located on the rear section of your Hurricane. See figure 7. Refer to IX. “Disassembly and Assembly” for instructions on removing the rear shroud.

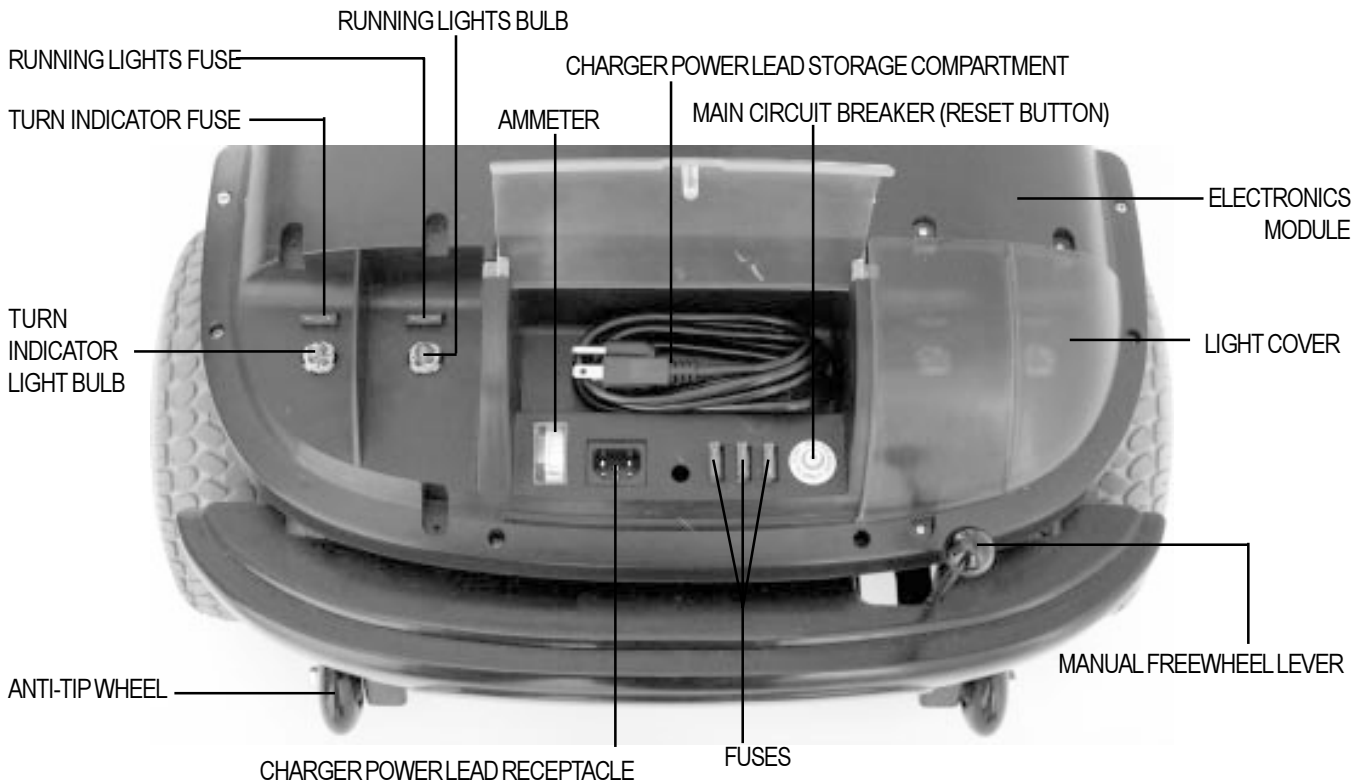

FIGURE 7. REAR SECTION (LEFT LIGHT COVER REMOVED FOR CLARITY)

Batteries

The batteries store the electrical energy that powers your Hurricane. See V. “Batteries and Charging.”

Main Circuit Breaker

When the voltage in your Hurricane’s batteries becomes low or your Hurricane is heavily strained because of excessive loads or steep inclines, the main circuit breaker may trip to protect your Hurricane’s motor and electronics from damage. See figure 7.

- The main circuit breaker reset button pops out when the breaker trips.
- When the breaker trips, the entire electrical system of your Hurricane shuts down.
- Allow a minute or two for your Hurricane’s electronics to “rest.”
- Push in the reset button to reset the breaker.
- If the breaker trips frequently, you may need to charge your batteries more often. You may also need to have your Pride provider perform a load test on your Hurricane’s batteries.
- If the main circuit breaker trips repeatedly, see your authorised Pride provider for service.

IV. YOUR HURRICANE

Manual Freewheel Lever

Whenever you need or want to push your Hurricane for short distances, you can put it in freewheel mode.



WARNING! Before placing your Hurricane into or taking it out of freewheel mode, make certain that the key is removed from the key switch. Never sit on a Hurricane when it is in freewheel mode. Never put a Hurricane in freewheel mode on any incline.

- The manual freewheel lever is located on the end of the motor/transaxle assembly at the right rear of the Hurricane. See figure 7.
- Pull up on the manual freewheel lever to disable the drive system and the brake system.
- You may now push your Hurricane.
- Push down on the manual freewheel lever to reengage the drive system and the brake system and take your Hurricane out of freewheel mode.

The Hurricane is equipped with a safety feature called “push-too-fast” which prevents the scooter from gaining excessive speed while being pushed in freewheel mode.

“Push-too-fast” operates differently depending on which of two conditions exists.

- When the scooter is powered down (off) and in freewheel mode, the controller activates regenerative braking that creates resistance when you push the scooter faster than a maximum speed which has been preprogrammed.
- When the scooter is powered up (on) with the manual freewheel lever in the drive (down) position, you will encounter considerable resistance if you try pushing the scooter. (It is recommended that you do not push the scooter with the key in the “on” position while in freewheel mode.)

Motor/Transaxle Assembly

The motor/transaxle assembly is the electromechanical unit that converts the electrical energy of your Hurricane’s batteries into the controlled mechanical energy that drives the Hurricane’s wheels.

Anti-Tip Wheels

The anti-tip wheels are an integral and important safety feature of your Hurricane. Do not, under any circumstances, remove the anti-tip wheels from your Hurricane. See figure 7.

Charger Power Lead Receptacle

The charger power lead plugs into your Hurricane’s battery charger by means of the charger power lead receptacle.

IV. YOUR HURRICANE

Fuses

The fuses help protect your Hurricane's lighting, control console assembly, and charging systems from receiving an overload of electrical current. The fuses used in the Hurricane are the same type automobiles use. See figure 8.

If a fuse must be replaced (see figure 9), use only the specified amp fuse. See XI. "Care and Maintenance."

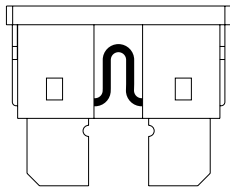

FIGURE 8. WORKING FUSE

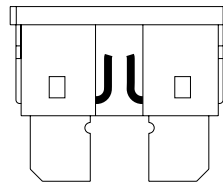

FIGURE 9. BLOWN FUSE (REPLACE)



WARNING! Failure to use properly rated fuses may cause damage to the Hurricane's electrical system, with the possibility of personal injury.

Hercules Docking Device

Your Hurricane is equipped with a Hercules 3000 docking device. See figure 10. In order to utilize the docking device, it is necessary to purchase an insert (T-bar or Bullnose and C-arm) that, when used with the Hercules 3000, will lift a Hurricane into a vehicle.

Contact your authorised Pride provider for more information about the docking device and the Hercules 3000 lift.

DOCKING DEVICE

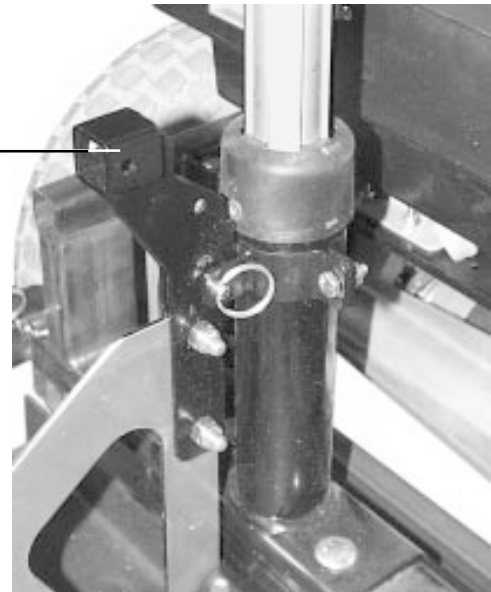

FIGURE 10. HERCULES 3000 DOCKING DEVICE

V. BATTERIES AND CHARGING

Your Hurricane uses two long-lasting, 12-volt, deep-cycle batteries that are sealed and maintenance free. They are recharged by an onboard charging system designed for ease of use and convenience.

- Charge your Hurricane's batteries prior to using it for the first time.
- Keep your batteries fully charged to keep your Hurricane running trouble-free.

Follow these easy steps to charge your batteries safely:

1. Position your Scooter close to a standard wall outlet.
2. Remove the key from the control console assembly.
3. Make certain that the freewheel lever is in the drive (down) position.
4. Plug the charger power lead into the charger power lead receptacle on the Scooter.
5. Extend the charger power lead and plug it into the wall outlet.



WARNING! Never use an extension lead to plug in your battery charger. Plug the charger directly into a properly wired standard wall outlet.

NOTE: There is a charger inhibit function on your Scooter. The Scooter will not run and the battery condition meter will not operate while the batteries are charging.

It is recommended that you charge your batteries for 8 to 14 hours. You can check this periodically by the battery condition meter on the control console assembly. However, you must first unplug the battery charger and then insert the key. The battery condition meter on the control console assembly indicates the approximate strength of your batteries. See figure 11.

- Green indicates the Hurricane's batteries are fully charged.
- Yellow indicates that the Hurricane's battery voltage level is getting low and will require a charge soon.
- Red indicates that your Hurricane's battery voltage level is very low, and the batteries should be recharged as soon as possible.

You can also check the charge by the ammeter which is visible on the rear electronics module. The battery charger must be plugged into a wall outlet to obtain a reading. When the amperage reading is at or near zero (0) amps, the battery charging is complete. See figure 12.

6. When the batteries are fully charged, unplug the charger power lead from the wall outlet and then from the charger power lead receptacle.
7. Place the charger power lead in the rear storage compartment for safekeeping.

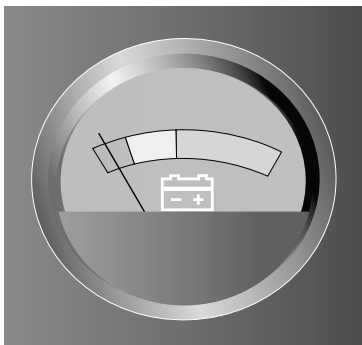

FIGURE 11. BATTERY CONDITION METER

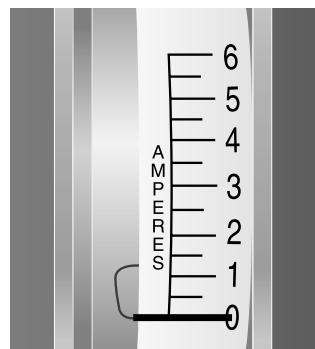

FIGURE 12. AMMETER INDICATES BATTERY IS FULLY CHARGED

V. BATTERIES AND CHARGING

BATTERIES AND CHARGING - FREQUENTLY ASKED QUESTIONS (FAQS)

How does the charger work?

When your Hurricane's battery voltage is low, the charger works harder sending more electrical current to the batteries to bring up their charge. As the batteries approach full charge, the charger sends less and less electrical current. When the batteries are fully charged, the current sent from the charger is at nearly zero amperage. Therefore, when the charger is plugged in, it maintains the charge on your Hurricane's batteries, but does not overcharge them. We do not recommend that you charge your Hurricane's batteries for more than 24 consecutive hours.

What if the Hurricane's batteries won't charge?

- Ensure that the battery cables are connected properly.
- Ensure that both ends of the charger lead are inserted fully.
- Examine the 5-amp charger fuse. If the fuse is blown, the batteries will not charge. See figures 8 and 9.

Can I use a different charger?

For the safest, most efficient and balanced charging of your Hurricane's batteries, we prefer and highly recommend the simultaneous charging of both batteries with the onboard battery charger.

How often must I charge the batteries?

Two major factors must be considered when deciding how often to charge your Hurricane's batteries:

- All day Scooter use on a daily basis.
- Infrequent or sporadic Scooter use.

With these considerations in mind, you can determine just how often and for how long you should charge your Hurricane's batteries. We designed the onboard charger so that it will not overcharge your Scooter's batteries (do not charge them for more than 24 consecutive hours). However, you may encounter some problems if you do not charge your batteries often enough and if you do not charge them on a regular basis. Following the five guidelines below will provide safe and reliable battery operation and charging.

- If you use your Hurricane daily, charge its batteries as soon as you finish using it for the day. Your Hurricane will be ready each morning to give you a full day of service. We recommend that you charge your Hurricane's batteries for 8 to 14 hours after daily use.
- If you use your Hurricane once a week or less, charge its batteries at least once a week for 12 to 14 hours at a time.
- Keep your Hurricane's batteries fully charged.
- Avoid deeply discharging your Hurricane's batteries.
- Do not charge your Hurricane's batteries for more than 24 consecutive hours.

V. BATTERIES AND CHARGING

How can I get maximum range or distance per charge?

Rarely will you have ideal driving conditions—smooth, flat, hard driving surfaces with no wind or curves. You will often face hills, walkway cracks, uneven and loosely packed surfaces, curves, and wind. All of these driving conditions affect the distance or running time per battery charge. Below are a few suggestions for obtaining the maximum range per battery charge.

- Always fully charge your Hurricane's batteries prior to your daily use.
- Maintain **30-35 psi** (pounds per square inch) in all of your Hurricane's tyres.
- Plan your route ahead to avoid as many hills, cracked, broken, or soft surfaces as possible.
- Limit your baggage weight to essential items.
- Try to maintain an even speed while your Hurricane is in motion.
- Avoid stop-and-go driving.

What type and size of battery should I use?

We recommend deep-cycle batteries that are sealed and maintenance free. Both sealed lead-acid and gel cell are deep-cycle batteries that are similar in performance. Do not use wet-cell batteries, which have removable caps.



CAUTION! Do not remove the caps from sealed batteries. Water cannot be added to sealed batteries. Cap removal voids the battery warranty and may cause damage to the batteries and to your Hurricane.

Use these specifications to reorder deep-cycle batteries:

Type: Deep-cycle (sealed lead-acid or gel cell)
Size: U-1 (32 AH only), 40 AH
Voltage: 12 volts each
Amperage: 32 AH or 40 AH

To change a battery in your Hurricane:



WARNING! Battery posts, terminals, and related accessories contain lead and lead compounds. Wash hands after handling.

1. Remove the seat and the rear shroud. See VIII. "Disassembly and Assembly."
2. Disconnect the battery tie-down strap (if equipped).
3. Disconnect the battery cables from the electronics module.
4. Disconnect the battery cables from the battery terminals.
5. Remove the old battery.
6. Place a new battery in the battery well.
7. Connect the red battery cable to the positive (+) battery terminal.
8. Connect the black battery cable to the negative (-) battery terminal.
9. Reconnect the battery cables to the electronics module.
10. Reconnect the battery tie-down strap (if equipped).
11. Reinstall the rear shroud and the seat.

Why do my new batteries seem weak?

Deep-cycle batteries employ a different chemical technology than that used in car batteries, nickel-cadmium batteries (nicads), or in other common battery types. Deep-cycle batteries are specifically designed to provide power, drain down their charge, and then accept a relatively quick recharge.

V. BATTERIES AND CHARGING

We work closely with our battery manufacturer to provide batteries that best suit your Hurricane's specific electrical demands. Fresh batteries arrive daily at Pride and are shipped fully charged to our customers. During shipping, the batteries may encounter temperature extremes that may influence their initial performance. Heat diminishes the charge on the battery; cold slows the available power and extends the time needed to recharge the battery.

It may take a few days for the temperature of your Hurricane's batteries to stabilize and adjust to their new room or ambient temperature. More importantly, it takes a few charging cycles (a partial drain followed by a full recharge) to establish the critical chemical balance that is essential to a deep-cycle battery's peak performance and long life.

Please follow these steps to properly break in your Hurricane's new batteries for maximum efficiency and service life.

1. Fully recharge any new battery prior to its initial use. This charging cycle brings the battery up to about 88% of its peak performance level.
2. Operate your new Hurricane in familiar and safe areas. Drive slowly at first, and do not travel too far from your home or familiar surroundings until you have become accustomed to your Hurricane's controls and have properly broken in your Hurricane's batteries.
3. Fully recharge the batteries. They should be at over 90% of their peak performance level.
4. Operate your Hurricane again.
5. Fully recharge the batteries again.
6. After four or five charging cycles, the batteries are able to receive a charge of 100% of their peak performance level and are able to last for an extended period of time.

How can I ensure maximum battery life?

Fully charged deep-cycle batteries provide reliable performance and extended battery life. Keep your Hurricane's batteries fully charged whenever possible. Batteries that are regularly and deeply discharged, infrequently charged, or stored without a full charge may be permanently damaged, causing unreliable performance and limited service life.

How should I store my Hurricane and its batteries?

If you plan on not using your Hurricane for an extended period of time, it is best to:

- Fully charge its batteries prior to storage.
- Disconnect the battery harnesses from the electronics module.
- Store your Hurricane in a warm, dry environment.
- Avoid storing your Hurricane where it will be exposed to temperature extremes.



WARNING! If your Hurricane's batteries do become frozen, do not attempt to charge them. Cold or frozen batteries should be allowed to warm up for several days prior to recharging.

For prolonged storage, you may wish to place several boards under the frame of your Hurricane to raise it off of the ground. This takes the weight off of the tyres and reduces the possibility of flat spots developing on the areas of the tyres contacting the ground.

What about public transportation?

If you intend to use public transportation while using your Hurricane, you must contact the transportation provider to in advance determine their specific requirements.

VI. OPERATION

BEFORE GETTING ON YOUR HURRICANE

- Fully charge the batteries? See V. “Batteries and Charging.”
- Place the manual freewheel lever in the drive (down) position. Never leave the manual freewheel lever pulled up unless you are manually pushing your Hurricane.

GETTING ON YOUR HURRICANE

1. Make certain that the key is removed from the key switch.



WARNING! Never attempt to board or exit your Hurricane without first removing the key from the key switch. This will prevent the Hurricane from moving if accidental contact with the throttle control lever is made.

2. Stand at the side of your Hurricane.
3. Pull up on the seat rotation lever and rotate the seat until it is facing you.
4. Make certain that the seat is locked securely in position.
5. Position yourself comfortably and securely in the seat.
6. Pull up on the seat rotation lever and rotate the seat until you are facing forward.
7. Make certain that the seat is locked securely in position.
8. Make certain that your feet are safely on the floorboard.
9. Follow the checklist below. Familiarize yourself with this checklist, since some of the checks must be performed before you get on your Hurricane.

PRE-RIDE ADJUSTMENTS AND CHECKS

- Is your proposed path clear of people, pets, and obstacles?
- Have you planned your route to avoid adverse terrain and as many inclines as possible?
- Are you positioned comfortably in the seat? See “Getting On Your Hurricane,” above.
- Is the seat at the proper height? See VII. “Comfort Adjustments.”
- Is the seat locked securely in place? See VII. “Comfort Adjustments.”
- Is the tiller handle at a comfortable setting and locked securely in place? See VII. “Comfort Adjustments.”
- Set the 6.5-13 km/h (4 - 8 mph) switch to your desired maximum speed of 6.5 or 13 km/h (4 or 8 mph); then set the speed adjustment dial to your desired speed. We recommend you initially set the 6.5-13 km/h (4 - 8 mph) switch to 6.5 km/h (4 mph) and adjust your speed to the slowest setting).
- Are the key fully inserted into the key switch and in the “on” position? See IV. “Your Hurricane.”
- Is the speed adjustment dial set to a slower setting? See IV. “Your Hurricane.”
- Are you grasping the handgrips with a thumb resting on each side of the throttle control lever? See IV. “Your Hurricane.”
- Does your Hurricane’s horn work properly?

OPERATING YOUR HURRICANE

After planning your route:

- Press your thumb against the appropriate throttle control lever.
- The electric brake automatically disengages and the Hurricane accelerates smoothly to the speed you preselected with the speed adjustment dial.

VI. OPERATION

WHETHER YOU ARE DRIVING FORWARD OR IN REVERSE

- Pull on the left handgrip to steer your Hurricane to the left.
- Pull on the right handgrip to steer your Hurricane to the right.
- Move the tiller to the center position to drive straight ahead.
- Release the throttle control lever to decelerate and come to a complete stop.
- The electric brake automatically engages when your Hurricane comes to a stop.

NOTE: The rear wheel drive transaxle gives your Hurricane maximum traction with minimal steering effort on your part.

GETTING OFF OF YOUR HURRICANE

1. Bring your Hurricane to a complete stop.
2. Make certain that the key is turned counterclockwise to the “off” position, and removed.
3. Pull up on the seat rotation lever and rotate the seat until you are facing toward the side of your Hurricane.
4. Make certain that the seat is locked securely in position.
5. Carefully and safely get out of the seat and stand to the side of your Hurricane.
6. You may, if you wish, leave the seat facing to the side to facilitate boarding your Hurricane the next time you are going to operate it.

VII. COMFORT ADJUSTMENTS



WARNING! Remove the key from the key switch before adjusting the tiller or the seat. Never attempt to adjust the tiller or the seat while the scooter is in motion.

TILLER ANGLE ADJUSTMENT

Your Hurricane is equipped with an ergonomically enhanced pivoting tiller that keeps the console controls at your fingertips regardless of the tiller angle.

1. Pull up on the tiller adjustment lever. See figure 13.
2. Move the tiller to a comfortable position.
3. Release the tiller adjustment lever. The tiller remains in the position you selected.

NOTE: In order to lower the tiller to the Hurricane deck, you must first remove the seat, rear shroud, and both batteries. See VIII. "Disassembly and Assembly."



FIGURE 13. TILLER ADJUSTMENT

SEAT HEIGHT ADJUSTMENT

The seat can be repositioned to one of five different heights.

1. Remove the seat from your Hurricane. See VIII. "Disassembly and Assembly."
2. Use the attached ring to pull and remove the ball detent pin from the lower seat post. See figure 14.
3. Raise or lower the seat pedestal to the desired seat height.
4. Hold the seat pedestal at that height and match up the holes in the seat pedestal and in the lower seat post.
5. Fully insert the ball detent pin.
6. Replace the seat.

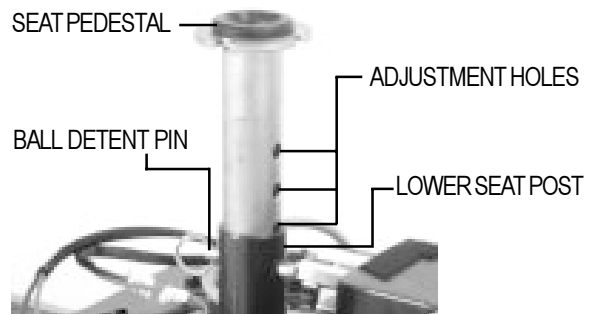

FIGURE 14. SEAT HEIGHT ADJUSTMENT

NOTE: The supplied nut, bolt, and washers can be used as an alternate to the ball detent pin for seat height adjustment and stability.

FRONT-TO-BACK SEAT ADJUSTMENT

The Hurricane is equipped with a sliding seat that is operated like an automobile seat. You can reposition the Hurricane's seat forward or rearward.

1. Pull out the front-to-back seat release lever. See figure 15.
2. Move the seat forward or rearward.
3. Release the front-to-back seat release lever.

VII. COMFORT ADJUSTMENTS

SEAT ROTATION

The seat lock lever locks the seat in one of four positions.

1. Push down on the seat lock lever to unlock the seat. See figure 15.
2. Rotate the seat to the desired position.
3. Release the seat lock lever to lock the seat securely in place.

ARMREST WIDTH ADJUSTMENT

The Hurricane armrest width can be adjusted inward or outward.

1. Loosen the armrest adjustment knobs at the back of the seat frame. See figure 16.
2. Slide the armrest uprights in or out to the desired width.
3. Tighten the armrest adjustment knobs.

The armrests can also be lifted upward to allow getting on and off of your Hurricane easier.

ARMREST HEIGHT ADJUSTMENT

Refer to figure 16 when adjusting the armrest height.

Required tools:

- 5/32-in. Hex Key
- 1/8-in. Hex Key
- 7/16-in. Spanner

1. Loosen the setscrew on the side of the height adjustment tube with the 1/8-in. hex key. See figure 16.
2. Loosen and remove the acorn nut and screw holding the height adjustment tube in place.
3. Raise or lower the height adjustment tube to the desired height.
4. Align the holes in the adjustment tube with the holes in the armrest upright.
5. Insert the screw through the holes in both the height adjustment tube and the armrest upright.
6. Install and tighten the acorn nut.
7. Tighten the setscrew on the side of the height adjustment tube.
8. Repeat for the other armrest.

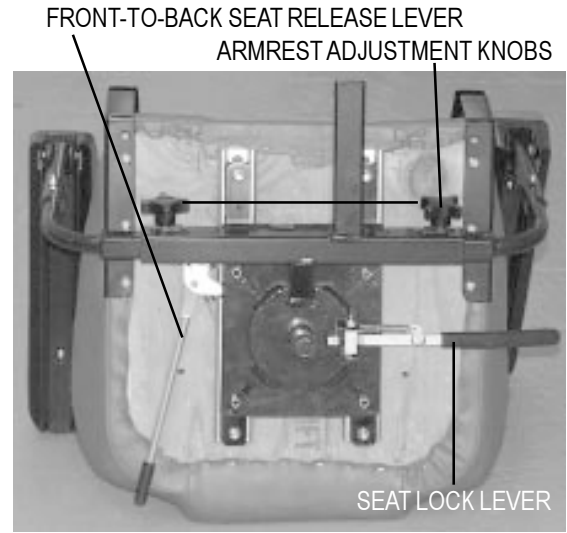

FIGURE 15. SEAT ADJUSTMENTS

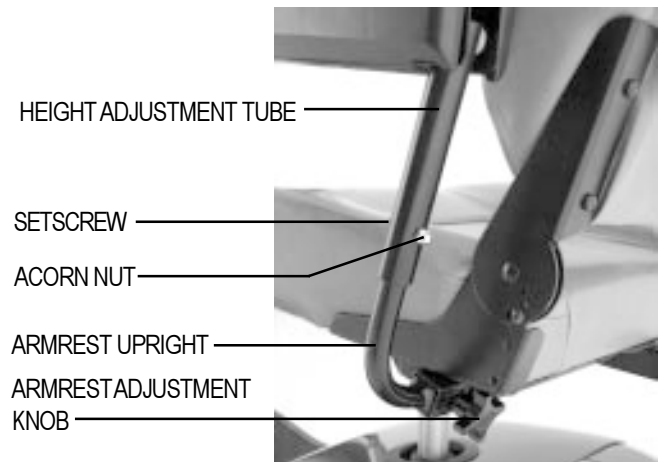

FIGURE 16. ARMREST ADJUSTMENTS

VII. COMFORT ADJUSTMENTS

SEATBACK ADJUSTMENT

The seatback may be positioned to four different angles: 90°, 100°, 102° and 105°. See figure 16A.

To adjust the seatback angle:

1. Loosen and remove the adjustment screw from the seatback hinge on both sides of the seat.
2. Reposition the seatback to the desired angle.
3. Align the adjustment holes from the upper and lower hinge, so the adjustment screw can easily pass through.
4. Reinsert both adjustment screws and tighten.

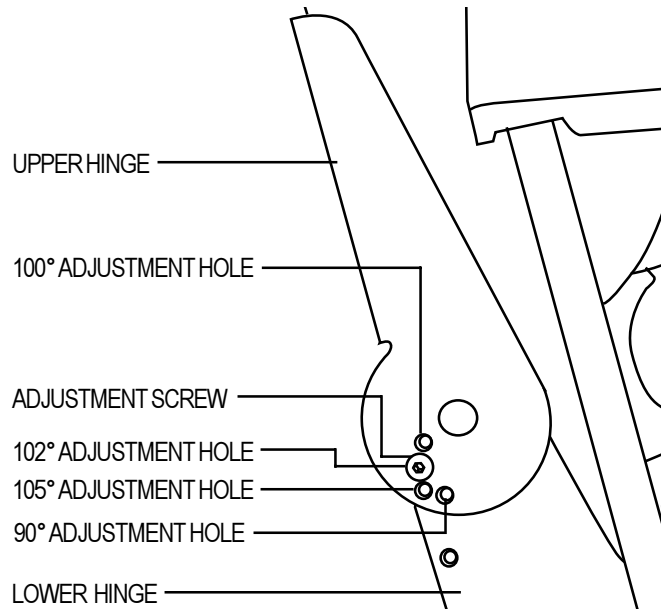

FIGURE 16A. SEATBACK HINGE

POWER SEAT ACTUATOR (OPTIONAL)

Your Hurricane may be equipped with a power seat actuator, which raises and lowers the seat automatically. See figure 17.



WARNING! The power seat mechanism is intended for operation only while the vehicle is stationary and on a level surface. Its purpose is to aid you in reaching objects. Strict adherence to the following safety rules is vital to your safety: Do not attempt to raise or lower the seat while in motion! Do not operate your Hurricane with the power seat elevated. It is recommended that the vehicle be driven only with the seat in the lowest position.



FIGURE 17. POWER SEAT ACTUATOR (OPTIONAL)

VIII. DISASSEMBLY AND ASSEMBLY

No tools are required to disassemble or assemble your Hurricane. Always disassemble or assemble your Hurricane on a level, dry surface with sufficient room for you to work and move around your scooter. Keep in mind that the disassembled sections of the Hurricane take up more floor space than the assembled scooter.

DISASSEMBLY

You can disassemble the Hurricane into seven pieces: the seat, the front section, the rear section, the rear shroud, the basket, and the batteries. Place the Hurricane in an area where you have sufficient clearance to move the parts around. You need about two meters in all directions. You may need assistance to lift some of the Hurricane components. See III. “Specifications” for individual component weights.

1. Place the manual freewheel lever in the drive (down) position.
2. Coil the charger power lead and store it in the rear storage compartment. See figure 7.
3. Pull up on the seat rotation lever to unlock the seat. Rotate the seat one eighth of a turn, and lift the seat up and off the Hurricane. See figure 18.
4. Gently lift the rear shroud off of the Hurricane. See figure 19.



FIGURE 18. SEAT REMOVAL



FIGURE 19. REAR SHROUD REMOVAL

5. Disconnect the battery tie-down strap.
6. Unplug both black and white 2-pin battery harnesses. See figure 20.
7. Unplug the silver front-to-rear harness that connects the control console assembly to the electronics module. See figure 21.



FIGURE 20. DISCONNECTING THE BATTERY HARNESSSES



FIGURE 21. DISCONNECTING THE FRONT-TO-REAR HARNESS



CAUTION! Failure to unplug both battery harnesses and the front-to-rear harness prior to disassembly could result in permanent damage to the Hurricane.

VIII. DISASSEMBLY AND ASSEMBLY

8. Lift both batteries off of the Hurricane. See figure 22.

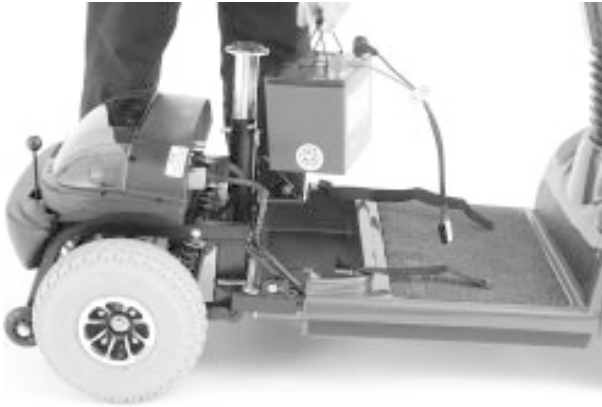

FIGURE 22. BATTERY REMOVAL

9. Disconnect the handbrake cable from the rear hub by pushing forward and holding the brake release lever with your thumb. See figure 23. Lift the cable release hook free of the peg and slide the handbrake cable free of its slot on the brake mount. See figure 24. Move the cable safely out of the way.

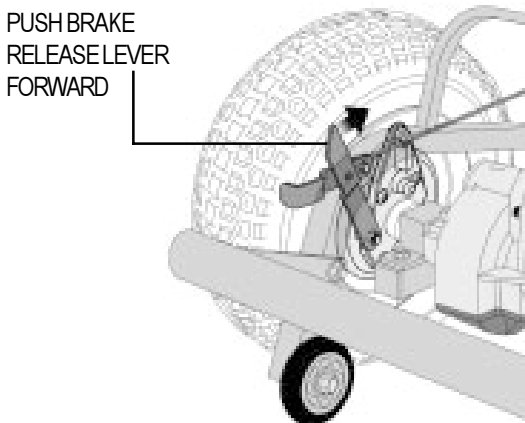

FIGURE 23. DISENGAGE HANDBRAKE CABLE

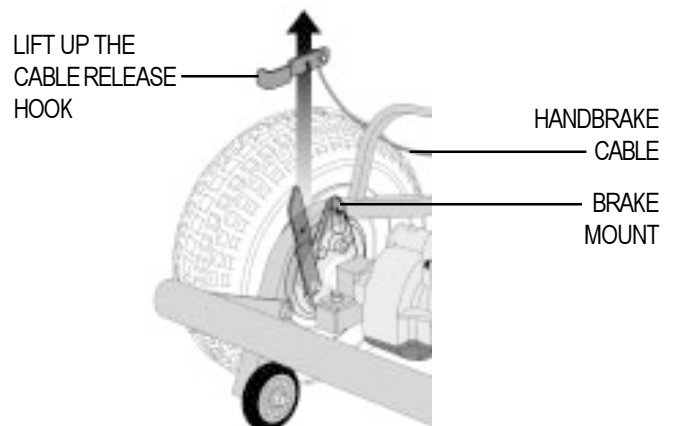

FIGURE 24. DISENGAGE HANDBRAKE CABLE

10. Push the locking cam levers forward and remove the ball detent pins. See figures 25 and 26.

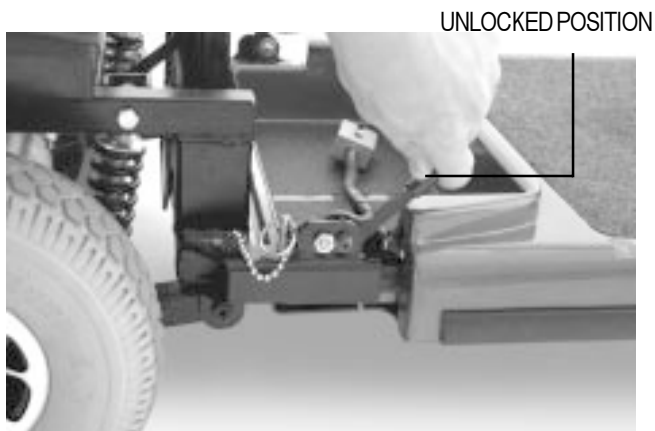

FIGURE 25. LOCKING CAM LEVERS

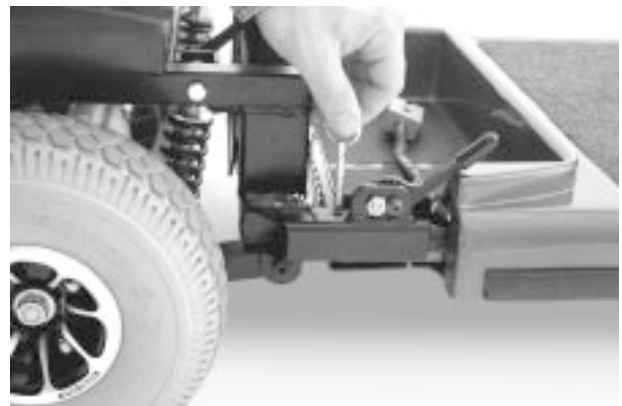

FIGURE 26. BALL DETENT PINS

VIII. DISASSEMBLY AND ASSEMBLY

11. Remove the docking device ball detent pin.
See figure 27.

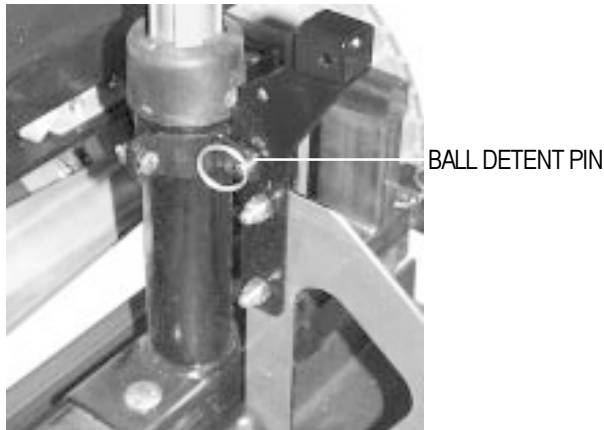

FIGURE 27. BALL DETENT PIN

12. Gently slide the two sections of the Hurricane apart.
See figure 28.



FIGURE 28. FRAME SEPARATION

13. Grab the handle grip on the tiller, pull upward on the tiller adjustment lever, and gently lower the tiller down to the center of the Hurricane chassis until it is fully lowered.

NOTE: There is no need to disconnect the motor harness when disassembling the Hurricane. See figure 29.

ASSEMBLY

NOTE: Raise the tiller before starting to assemble the Hurricane.

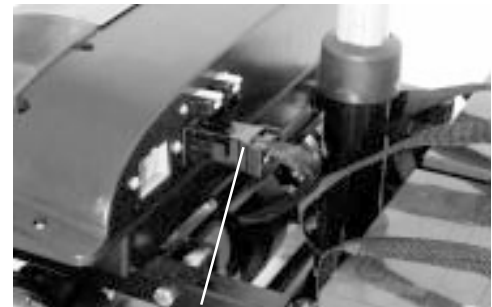

FIGURE 29. MOTOR HARNESS

1. Place the manual freewheel lever in the drive (down) position.
2. Position the front and rear sections next to each other.
3. Tilt the rear end to a horizontal position and insert the longer tube of the front end into the rear section first; make sure that the locking cam levers are in the unlocked (vertical) position and the ball detent pins are removed.
4. Slide the two sections of the unit together until the front half reaches its insertion limit.
5. Secure the front and rear sections with the ball detent pins.
6. Push the frame lock levers back to their locked (downward) position.
7. Replace the ball detent pin into the docking device.
8. Plug the silver front-to-rear harness into the mating plug found on the electronics module.
9. Put the batteries in place and plug the black and white 2-pin battery harnesses into the electronics module.
10. Reconnect the battery tie-down strap.
11. Reconnect the handbrake cable by sliding the cable into its slot on the brake mount. With your thumb, push forward and hold the brake release lever, then slide the cable release hook onto the peg and gently let go of the brake release lever.
12. Gently place the rear shroud over the seat post.
13. Lower the shroud into place.
14. Carefully lift the seat and slide the seat platform (on the seat bottom) onto the seat pedestal.
15. Rotate the seat until it locks into place.

IX. OPTIONAL ACCESSORIES

OPTIONAL ACCESSORIES

For information concerning these optional accessories, contact your authorised Pride provider.



• CUP HOLDER



• SAFETY FLAG



• REAR BASKET

X. BASIC TROUBLESHOOTING

Any electromechanical device occasionally requires some troubleshooting. However, most of the problems that may arise can usually be solved with a bit of thought and common sense. Many of these problems occur because the batteries are not fully charged or because the batteries are worn down and can no longer hold a charge.

DIAGNOSTIC FLASH CODES

The diagnostic flash codes for your Hurricane are designed to help you perform basic troubleshooting quickly and easily. A diagnostic flash code will flash from the status LED in the event one of the conditions listed below develops.

NOTE: Your Hurricane will not run unless the flash code condition is resolved and the Hurricane has been turned off, then turned back on.

FLASH CODE	CONDITION	SOLUTION
■ ■ ■ ■ ■	Batteries are too low to operate the scooter or the charger is operating.	Charge batteries or unplug the charger power lead from the electrical outlet.
■ ■	Controller is hot; the scooter seems to be losing power.	Shut down your scooter for a minimum of several minutes to allow the controller to cool.
■ ■ ■ ■	Wigwag fault; your throttle control lever is not responding.	Call your authorised Pride provider for assistance.
■ ■ ■ ■ ■	The manual freewheel lever is in the (up) freewheel position.	Turn the scooter key to the off position, then push the manual freewheel lever to the (down) drive position: restart your scooter.
■ ■ ■ ■ ■ ■ ■	The scooter is operating with the charger attached.	Unplug the charger lead from the charger power lead receptacle.

What if all the systems on my Hurricane seem to be “dead”?

- Make certain that the key is in the “on” position.
- Check that the batteries are fully charged. See V. “Batteries and Charging.”
- Push in the main circuit breaker reset button. See IV. “Your Hurricane.”
- Make certain that both battery harnesses are firmly connected to the electronics module and to the battery terminals. See VIII. “Disassembly and Assembly.”
- Make sure that the silver front-to-rear harness is firmly connected to the electronics module. See VIII. “Disassembly and Assembly.”
- Be sure the auto shutoff feature hasn’t been activated. See V. “Batteries and Charging.”
- Check the fuses. See XI. “Care and Maintenance” for fuse replacement.

What if the motor runs but my Hurricane does not move?

- With the key turned to the “on” position, check the status LED. If the LED flashes three times, pauses briefly, then flashes twice, this is the manual freewheel lever code meaning your Hurricane is in freewheel mode. See table above
- When the manual freewheel lever is pulled up, the brakes are disengaged and all power to the transaxle is cut.
- Push down the manual freewheel lever to restore normal operation to your Hurricane. See IV. “Your Hurricane.”

X. BASIC TROUBLESHOOTING

What if the main circuit breaker repeatedly trips? See IV. “Your Hurricane.”

- Charge the Hurricane’s batteries more frequently. See V. “Batteries and Charging.”
- If the problem continues, have both of your Hurricane’s batteries load tested by your authorised Pride provider.
- You may also perform the load test yourself. Battery load testers are available at most automotive parts stores.
- Follow the directions supplied with the load tester.
- See V. “Batteries and Charging” or III. “Specifications” for information about your Hurricane’s battery type.

What if the battery condition meter dips way down and the motor surges or hesitates when I press the throttle control lever? (See IV. “Your Hurricane.”)

- Fully charge your Hurricane’s batteries. See V. “Batteries and Charging.”
- Have your authorised Pride provider load test each battery.
- Or, see the previous troubleshooting question for load testing the batteries yourself.

If you experience any problems with your Hurricane that you are not able to solve, immediately contact your authorised Pride provider for information, maintenance, and service.

XI. CARE AND MAINTENANCE

Your Hurricane requires a minimal amount of care and maintenance. If you do not feel confident in your ability to perform the maintenance listed below, you may schedule inspection and maintenance at your authorised Pride provider. The following areas require periodic inspection and/or care and maintenance.

TYRE PRESSURE

- For optimum Hurricane performance, we recommend that the tyre pressure be maintained at **30-35 psi**.



WARNING! Do not exceed 35 psi; overinflating a tyre can cause it to explode.

- Regularly inspect your Hurricane's tyres for signs of wear.
- Use a rubber conditioner on your Hurricane's tyres to help preserve them.
- Do not put rubber conditioner on tyre tread; this may cause the tyres to become dangerously slippery.

EXTERIOR SURFACES

- Bumpers and trim also benefit from an occasional application of rubber or vinyl conditioner.



WARNING! Do not use a rubber or vinyl conditioner on the Hurricane's vinyl seat or tyre tread; they will become dangerously slippery.

BATTERY TERMINAL CONNECTIONS

- Make certain that the terminal connections remain tight and uncorroded.
- The batteries must sit flat in the battery wells.
- The battery terminals should face the rear of the Hurricane.

WIRING HARNESSES

- Regularly check all wiring connections.
- Regularly check all wiring insulation, including the charger power lead, for wear or damage.
- Have your authorised Pride provider repair or replace any damaged connector, connection, or insulation that you find before using your Hurricane again.

ABS PLASTIC SHROUDS

- The front console shroud, front shroud, and the rear shroud are formed from durable ABS plastic and coated with an advanced formula urethane paint.
- A light application of car wax will help the shrouds retain their high gloss.

AXLE BEARINGS AND THE MOTOR/TRANSAXLE ASSEMBLY

- These items are all prelubricated, sealed, and require no subsequent lubrication.

MOTOR BRUSHES

- The motor brushes are housed inside of the motor transaxle/assembly. They should be inspected periodically for wear by your Pride provider.

CONTROL CONSOLE ASSEMBLY, CHARGER, AND ELECTRONICS MODULE

- Keep these areas free of moisture.
- If any of these items do become exposed to moisture, let them dry thoroughly before operating your Hurricane again.

XI. CARE AND MAINTENANCE

STORAGE

See V. “Batteries and Charging.”

REAR LIGHTS

The light bulbs for the rear running lights and turn indicators are easily replaceable.

NOTE: Replacement light bulbs can be purchased from your authorised Pride provider.

- Remove the light cover which is held in place with three (3) Phillips head screws.
- Gently remove the bulb by pulling it straight up. See figure 7.
- Insert a new 24V, 5-watt bulb.
- Replace the light cover.

FUSES

In the event a fuse should cease to work:

- Remove the fuse by pulling it up and out of its slot.
- Examine the fuse to be sure it is blown. See figures 8 and 9.
- Insert a new fuse of the proper rating.
- Turning signals and rear lights — replace with a 3-amp fuse. Each light bulb has its own fuse.
- Control console assembly — replace with a 3-amp fuse.
- Charging system — replace with a 5-amp fuse.

XII. WARRANTY

TWO-YEAR LIMITED WARRANTY

Structural frame components, including: platform, fork, seat post, and frame welds.
Drive train, including: differential, motor, and brake.

ONE-YEAR LIMITED WARRANTY

Your Pride Scooter is fully guaranteed for twelve (12) months from the date of purchase against faults arising due to defects in manufacture or materials. This warranty does not detract from, but is in addition to your legal rights.

All electronic parts, including controllers and battery chargers, have a one (1) year warranty. Servicing to the controller or battery charger must be carried out by your authorised Pride provider. Any attempt to open or dismantle these items renders the warranty void on that item.

NOT COVERED UNDER WARRANTY

This warranty does not extend to those items which may need replacement due to normal wear and tear (tyres, belts, bulbs, upholstery, plastic shrouds, motor brushes, fuses, and batteries), or damage to the product caused by misuse or accident for which Pride or its agent cannot be held responsible. This warranty does not include labor or service calls.

BATTERIES

Batteries are covered by a twelve (12) month warranty from the original manufacturer.

Gradual deterioration in performance due to being left in a discharged state, left in cold conditions for long periods of time, or worn out through heavy use is not covered.

SERVICE CHECKS AND WARRANTY SERVICE

Warranty service can be performed by an authorised Pride provider. Please contact your authorised Pride provider for advice on the current cost affecting a service visit.



Pride
Mobility Products Ltd.

**Unit 106 Heyford Park Camp Road
Upper Heyford Oxfordshire OX25 5HA**

www.pridemobility.com