

# Legend XL

## Owner's Manual

**ATTENTION:**  
Please read the content  
of your owner's manual  
before operating your  
scooter.



*The Ultimate In Style & Performance<sup>®</sup>*

**Pride**  
Mobility Products Ltd.

*Unit 106, Heyford Park Camp Road  
Upper Heyford, Oxfordshire OX25 5HA*

[www.pridemobility.com](http://www.pridemobility.com)

# SAFETY GUIDELINES

Please read and follow all instructions in this owner's manual before attempting to operate your scooter for the first time. If there is anything in this manual you do not understand, or if you require additional assistance for set-up, contact your scooter specialist.

Using your Pride product safely depends upon your diligence in following the warnings, cautions, and instructions in this owner's manual. Using your Pride product safely also depends upon your own good judgement and/or common sense, as well as that of your provider, caregiver, and/or healthcare professional. Pride is not responsible for injuries and/or damage resulting from any person's failure to follow the warnings, cautions, and instructions in this owner's manual. Pride is not responsible for injuries and/or damage resulting from any person's failure to exercise good judgement and/or common sense.

The symbols below are used throughout this owner's manual and/or on the scooter to identify warnings, cautions, and important information. It is very important for you to read and understand them completely. Additional symbols are identified in II. "Safety."



**WARNING! Failure to follow designated procedures can cause personal injury or component damage or malfunction (on the scooter-black symbol on yellow triangle with black border).**



**PROHIBITED! These actions should be prohibited. These actions should not be performed at any time or in any circumstances. Performing a prohibited action can cause injury to personnel and/or damage to equipment (black symbol with red circle and red slash).**



**NOTE: Supplemental information that may be helpful to operate the equipment.**



Copyright © 2003  
Pride Mobility Products Ltd.

INFMANU2367

# CONTENTS

|   |    |
|---|----|
| <b>I. INTRODUCTION</b> .....                | 4  |
| <b>II. SAFETY</b> .....                     | 6  |
| <b>III. SPECIFICATIONS</b> .....            | 17 |
| <b>IV. YOUR SCOOTER</b> .....               | 19 |
| <b>V. BATTERIES AND CHARGING</b> .....      | 23 |
| <b>VI. OPERATION</b> .....                  | 27 |
| <b>VII. COMFORT ADJUSTMENTS</b> .....       | 29 |
| <b>VIII. DISASSEMBLY AND ASSEMBLY</b> ..... | 32 |
| <b>IX. BASIC TROUBLESHOOTING</b> .....      | 34 |
| <b>X. CARE AND MAINTENANCE</b> .....        | 36 |
| <b>XI. OPTIONAL ACCESSORIES</b> .....       | 38 |
| <b>XII. WARRANTY</b> .....                  | 39 |

# I. INTRODUCTION

Welcome to Pride Mobility Products, Ltd. (Pride). Congratulations on the purchase of your new Pride Scooter. Your scooter design combines the most advanced state-of-the-art components with modern, attractive styling. We are certain that the design features and trouble-free operation will add convenience to your daily living and ensure complete satisfaction.

At Pride, your safety is important to us. **Please read and follow all of the instructions in this manual before you attempt to operate your scooter for the first time.** These instructions were produced for your benefit. Your understanding of these instructions is essential for the safe operation of your new Pride Scooter.

Pride is not liable for damage to property or personal injury arising out of the unsafe use of a Pride Scooter. Pride is also not liable for any property damage or personal injury arising out of the failure of any person and or/user to following the instructions and recommendations set forth in this manual or any other instructions or recommendations contained in other scooter related literature issued by Pride or contained on the Pride Scooter itself.

This owner's manual is compiled from the latest specifications and product information available at the time of publication. We reserve the right to make changes as they become necessary. Any changes to our products may cause slight variations between the illustrations and explanations in this manual and the product you have purchased.

If you experience any problems with your scooter that you are unable to solve, or if you do not feel capable of safely following any of the instructions and/or recommendations contained in this manual, please contact your authorised Pride Dealer for assistance.

Once you understand how to operate and take care of your scooter, we are certain that it will give you years of trouble-free service and enjoyment.

## Information Exchange

We want to hear your questions, comments, and suggestions regarding this manual. We would also like to hear about the safety and reliability of your new Pride Scooter and the service you received from your authorised Pride Dealer.

Please notify us of any change of address so we can keep you apprised of important information regarding safety, new products, and new options that can increase your ability to use and enjoy your Pride Scooter. Please feel free to write us at the address below:

Pride Mobility Products Ltd.  
Unit 106, Heyford Park Camp Road  
Upper Heyford, Oxfordshire OX25 5HA

# I. INTRODUCTION

## My Authorised Pride Dealer Is:

Name: \_\_\_\_\_

Address: \_\_\_\_\_

## Quick Reference Information:

Scooter Model: \_\_\_\_\_

Serial Number: \_\_\_\_\_

Purchase Date: \_\_\_\_\_



**NOTE: If you ever lose or misplace your product registration card or owner's manual, write to us and we will be glad to send you a new one immediately.**

# II. SAFETY

## PRODUCT SAFETY SYMBOLS

The symbols below are used on the scooter to identify warnings, mandatory actions, and prohibited actions. It is very important for you to read and understand them completely.



**Pinch/Crush points created during assembly.**



**Corrosive chemicals contained in battery. Use only AGM or Gel-Cell batteries to reduce the risk of leakage or explosive conditions.**



**Read and follow the information in the owner's manual.**



**Maximum seating weight.**



**Unlocked and in freewheel mode.**

**Place unit on level ground and stand behind or to one side when changing from drive mode to freewheel mode or freewheel mode to drive mode.**

**Locked and in drive mode.**

## II. SAFETY

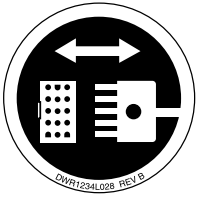

**Front-to-rear plug orientation.**



**Do not raise or lower the power seat while the scooter is in motion.**



**Do not remove anti-tip wheels.**



**Do not use a cell phone, walkie/talkie, laptop, or other radio transmitter while operating.**



**Avoid exposure to rain, snow, ice, salt, or standing water whenever possible. Maintain and store in a clean and dry condition.**



**Removal of grounding prong can create electrical hazard. If necessary, properly install an approved 3-pronged adapter to an electrical outlet having 2-pronged plug access. Failure to heed could result in personal injury and/or property damage.**

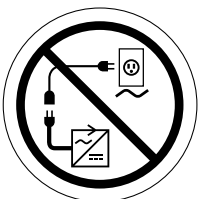

**Prevent personal injury and equipment damage. Do not connect an extension lead to the AC/DC converter or the battery charger.**

## II. SAFETY

### GENERAL



**WARNING! Do not operate your new scooter for the first time without completely reading and understanding this owner's manual.**

Your scooter is a state-of-the-art life-enhancement device designed to increase mobility. Pride provides an extensive variety of products to best fit the individual needs of the scooter user. Please be aware that the final selection and purchasing decision regarding the type of scooter to be used is the responsibility of the scooter user who is capable of making such a decision and his/her healthcare professional (i.e., medical doctor, physical therapist, etc.).

The contents of this manual are based on the expectation that a mobility device expert has properly fitted the scooter to the user and has assisted the prescribing healthcare professional and/or the authorised Pride Dealer in the instruction process for the use of the product.

There are certain situations, including some medical conditions, where the scooter user will need to practice operating the scooter in the presence of a trained attendant. A trained attendant can be defined as a family member or care professional specially trained in assisting a scooter user in various daily living activities.

As you begin using your scooter during daily activities, you will probably encounter situations in which you will need some practice. Simply take your time and you will soon be in full and confident control as you maneuver through doorways, on and off lifts, up and down ramps, and over moderate terrain.

Below are some precautions, tips, and other safety considerations that will help the user become accustomed to operating the scooter safely.

### MODIFICATIONS

Pride has designed and engineered your scooter to provide maximum mobility and utility. A wide range of accessories is available from your authorised Pride Dealer to further customise your scooter to better suit your needs and/or preferences. However, under no circumstances should you modify, add, remove, or disable any feature, part, or function of your scooter.



**WARNING! Do not modify your scooter in any way not authorised by Pride. Unauthorised modifications may result in personal injury and/or damage to your scooter.**

### REMOVABLE PARTS



**WARNING! Do not attempt to lift or move your scooter by any of its removable parts. Personal injury and damage to the scooter may result.**



# II. SAFETY

## PRE-RIDE SAFETY CHECK

Get to know the feel of your scooter and its capabilities. Pride recommends that you perform a safety check before each use to make sure your scooter operates smoothly and safely. For details on how to perform these necessary inspections, see X. "Care and Maintenance."

Perform the following inspections prior to using your scooter:

- Check for proper tyre inflation (if equipped with pneumatic tyres).
- Check all electrical connections. Make sure they are tight and not corroded.
- Check all harness connections. Make sure they are secured properly.
- Check the brakes.
- Check battery charge.

## TYRE INFLATION

If your scooter is equipped with pneumatic tyres, you should check or have the air pressure checked at least once a week. Proper inflation pressures will prolong the life of your tyres and help ensure the smooth operation of your scooter.



**WARNING! It is critically important that 30-35 psi (2-2.5 bar) tyre pressure be maintained in pneumatic tyres at all times. Do not underinflate or overinflate your tyres. Low pressure may result in loss of control, and overinflated tyres may burst. Failure to maintain 30-35 psi (2-2.5 bar) tyre pressure in pneumatic tyres at all times may result in tyre and/or wheel failure, causing serious personal injury and/or damage to your scooter.**

**WARNING! Inflate your scooter tyres from a regulated air source with an available pressure gauge. Inflating your tyres from an unregulated air source could overinflate them, resulting in a burst tyre and/or personal injury.**

## WEIGHT LIMITATIONS

Your scooter is rated for a maximum weight capacity. Refer to the specifications table for information.



**WARNING! Exceeding the weight capacity voids your warranty and may result in personal injury and damage to your scooter. Pride will not be held responsible for injuries and/or property damage resulting from failure to observe weight limitations.**

**WARNING! Do not carry passengers on your scooter. Carrying passengers may result in personal injury and/or property damage.**

## INCLINE INFORMATION

More and more buildings have ramps with specified degrees of inclination, designed for easy and safe access. Some ramps may have turning switchbacks (180-degree turns) that require you to have good cornering skills on your scooter.

- Proceed with extreme caution as you approach the downgrade of a ramp or other incline.
- Take wide swings with your scooter around any tight corners. If you do that, the scooter's rear wheels will follow a wide arc, not cut the corner short, and not bump into or get hung up on any railing corners.
- When driving down a ramp, keep the scooter's speed adjustment set to the slowest speed setting to ensure a safely controlled descent.
- Avoid sudden stops and starts.

## II. SAFETY

When climbing an incline, try to keep your scooter moving. If you must stop, start up again slowly, and then accelerate cautiously. When driving down an incline, do so by setting the speed adjustment dial to the slowest setting and driving in the forward direction only. If your scooter starts to move down the incline faster than you anticipated or desired, allow it to come to a complete stop by releasing the throttle control lever. Then push the throttle control lever forward slightly to ensure a safely controlled descent.

**WARNING! When climbing an incline, do not zigzag or drive at an angle up the face of the incline. Drive your scooter straight up the incline. This greatly reduces the possibility of a tip or a fall. Always exercise extreme caution when negotiating an incline.**

**WARNING! Do not drive your scooter across the side of an incline or diagonally up or down an incline; do not stop, if possible, while driving up or down an incline.**



**WARNING! You should not travel up or down a potentially hazardous incline (i.e., areas covered with snow, ice, cut grass, or wet leaves).**

**WARNING! When on any sort of an incline or decline, never place the scooter in freewheel mode while seated on it or standing next to it.**

**WARNING! Even though your scooter is capable of climbing slopes greater than those illustrated in figure 1, do not, under any circumstances, exceed the incline guidelines or any other specifications presented in this manual. Doing so could cause instability in your scooter, resulting in personal injury and/or damage to your scooter.**

Handicap public access ramps are not subject to government regulation in all countries, and therefore do not necessarily share the same standard percent of slope. Other inclines may be natural or, if man-made, not designed specifically for scooters. Figure 1 illustrates your scooter's stability and its ability to climb grades under various weight loads and under controlled testing conditions.

These tests were conducted with the scooter's seat in the highest position and adjusted rearward on the seat base to its farthest rearward position. Use this information as a guideline. Your scooter's ability to travel up inclines is affected by your weight, your scooter's speed, your angle of approach to the incline, and your scooter setup.

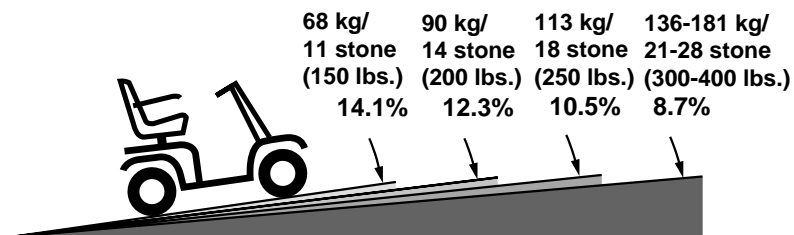

Figure 1. Maximum Recommended Incline Angles

**WARNING! Any attempt to climb or descend a slope steeper than what is shown in figure 1 may put your scooter in an unstable position and cause it to tip, resulting in personal injury.**



**WARNING! Never carry an oxygen tank weighing more than 7 kg (15 lbs.). Never fill the rear basket with contents exceeding 7 kg (15 lbs.).**

## II. SAFETY

When you approach an incline, it is best to lean forward. See figures 2 and 2A. This shifts the center of gravity of you and your scooter toward the front of the scooter for improved stability.



Figure 2. Normal Driving Position

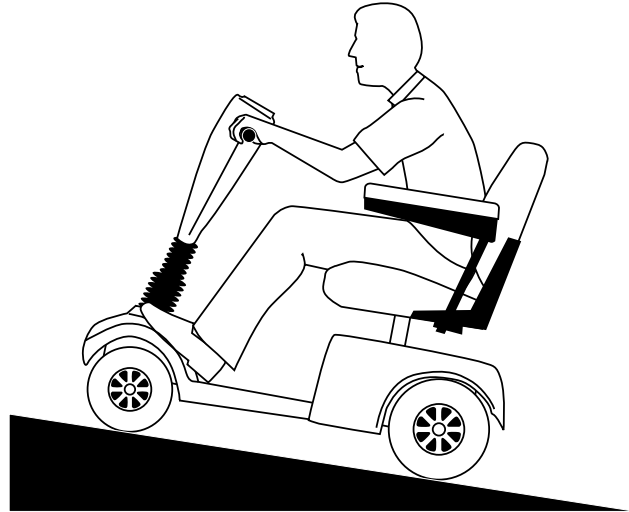

Figure 2A. Increased Stability Driving Position

### CORNERING INFORMATION

Excessively high cornering speeds can create the possibility of tipping. Factors which affect the possibility of tipping include, but are not limited to, cornering speed, steering angle (how sharply you are turning), uneven road surfaces, inclined road surfaces, riding from an area of low traction to an area of high traction (such as passing from a grassy area to a paved area – especially at high speed while turning), and abrupt directional changes. High cornering speeds are not recommended. If you feel that you may tip over in a corner, reduce your speed and steering angle (i.e., lessen the sharpness of the turn) to prevent your scooter from tipping.



**WARNING! When cornering sharply, reduce your speed. When using your scooter at higher speeds, do not corner sharply. This greatly reduces the possibility of a tip or fall. To avoid personal injury or property damage, always exercise common sense when cornering.**

### BRAKING INFORMATION

Your scooter is equipped with two powerful brake systems:

1. Regenerative: Uses electricity to rapidly slow the vehicle when the throttle control lever returns to the center/stop position.
2. Disc Park Brake: Activates mechanically after regenerative braking slows the vehicle to near stop, or when power is removed from the system for any reason.
3. Hand Brake: Gives you additional stopping power when you squeeze it.

## II. SAFETY

### OUTDOOR DRIVING SURFACES

Your scooter is designed to provide optimum stability under normal driving conditions—dry, level surfaces composed of concrete, blacktop, or asphalt. However, Pride recognises that there will be times when you will encounter other surface types. For this reason, your scooter is designed to perform admirably on packed soil, grass, and gravel. Feel free to use your scooter safely on lawns and in park areas.

- Reduce your scooter's speed when driving on uneven terrain and/or soft surfaces.
- Avoid tall grass that can become tangled in the running gear.
- Avoid loosely packed gravel and sand.
- If you feel unsure about a driving surface, avoid that surface.

### STREETS AND ROADWAYS



**WARNING!** Use extreme caution when operating your scooter on public streets and roadways. Be aware that it may be difficult for traffic to see you when you are seated on your scooter. Obey all local pedestrian traffic rules. Wait until your path is clear of traffic, and then proceed with extreme caution.



**NOTE:** Safety accessories like fluorescent flags are available to order from your authorised Pride Dealer.

### STATIONARY OBSTACLES (STEPS, KERBS, ETC.)



**WARNING!** Do not drive near raised surfaces, unprotected ledges, and/or drop-offs (kerbs, porches, stairs, etc.).

**WARNING!** Do not attempt to have your scooter climb or descend an obstacle that is inordinately high. Serious personal injury and/or damage may result.

**WARNING!** Do not attempt to have your scooter proceed rearward down any step, kerb, or other obstacle. This may cause the scooter to tip and cause personal injury.

**WARNING!** Be sure your scooter is traveling perpendicular to any kerb you may be required to ascend or descend. See figures 3 and 3A.

**WARNING!** Do not attempt to negotiate a kerb that has a height greater than 5 cm (2 in.).

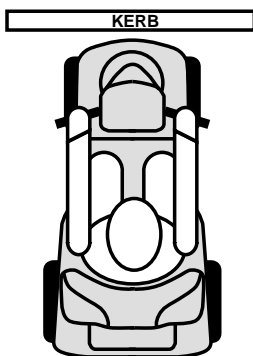

Figure 3. Correct Kerb Approach

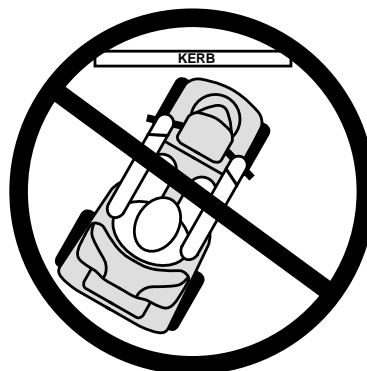

Figure 3A. Incorrect Kerb Approach

## II. SAFETY

### INCLEMENT WEATHER PRECAUTIONS



**WARNING! Pride recommends that you do not operate your scooter in icy or slippery conditions or on salted surfaces (i.e., walks or roads). Such use may result in an accident, personal injury, or adversely affect the performance and safety of your scooter.**

**WARNING! Do not operate or store your scooter where it may be exposed to inclement weather conditions such as rain, snow, mist, and below freezing temperatures (such as storage on an outside car/van lift). Attempting to operate the scooter in such conditions can damage the electronics and potentially result in loss of control.**

### FREEWHEEL MODE

Your scooter is equipped with a manual freewheel lever that, when pulled up, allows the scooter to be pushed. For more information about how to place your scooter into and out of freewheel mode, see IV. “Your Scooter.”



**WARNING! When your scooter is in freewheel mode, the braking system is disengaged.**

- **Disengage the drive motors only on a level surface.**
- **Ensure the key is removed from the key switch.**
- **Stand behind the scooter to engage or disengage freewheel mode. Never sit on a scooter to do this.**
- **After you have finished pushing your scooter, always return it to the drive mode to lock the brakes.**

**Failure to heed the above could result in personal injury and/or damage to your scooter.**

An added feature built into the Legend XL is “push-too-fast” protection which safeguards the scooter against gaining excessive speed while in freewheel mode.

“Push-too-fast” operates differently depending on which of two conditions exists:

- If the key is switched “off” while in freewheel mode, the scooter’s controller activates regenerative braking when the scooter is pushed faster than a maximum threshold which has been preprogrammed. In this case, the controller is acting as a speed governor.
- If the key is switched “on” while in freewheel mode, you will encounter considerable resistance at any speed. This prevents the scooter from gaining unwanted momentum should the manual freewheel lever inadvertently be released while driving the scooter.

## II. SAFETY

### STAIRS AND ESCALATORS

Scooters are not designed to travel up or down stairs or escalators. Always use a lift.



**WARNING! Do not use your scooter to negotiate steps or escalators. You may cause injury to yourself and to others and/or damage your scooter.**

### DOORS

- Determine if the door opens toward or away from you.
- Use your hand to turn the knob or push the handle or push-bar.
- Drive your scooter gently and slowly forward to push the door open. Or drive your scooter gently and slowly rearwards to pull the door open.

### LIFTS

Modern lifts have a door edge safety mechanism that, when pushed, reopens the door(s).

- If you are in the doorway of a lift when the door(s) begin to close, push on the rubber door edge or allow the rubber door edge to contact the scooter and the door will reopen.
- Use care that pocketbooks, packages, or scooter accessories do not become caught in lift doors.

*NOTE: If your scooter's turning radius is greater than 1500 mm (60 in), it may be difficult to maneuver in lifts and building entrances. Use caution when attempting to turn or maneuver your scooter in small spaces, and avoid areas that might pose a problem.*

### LIFT/ELEVATION PRODUCTS

If you will be traveling with your scooter, you may find it necessary to use a lift/elevation product to aid in transportation. Pride recommends that you closely review the instructions, specifications, and safety information set forth by the manufacturer of the lift/elevation product before using that product.

### BATTERIES

In addition to following the warnings below, be sure to comply with all other battery handling information.



**WARNING! Scooter batteries are heavy (refer to specifications table). Lifting weight beyond your capacity could result in personal injury. If necessary, get someone physically able to lift the scooter batteries for you.**

**WARNING! Battery posts, terminals, and related accessories contain lead and lead compounds. Wash hands after handling.**

**WARNING! Always protect the batteries from freezing and never charge a frozen battery. Charging a frozen battery may result in personal injury and/or damage to the battery.**

**WARNING! RED (+) cables must be connected to positive (+) battery terminals/posts. BLACK (-) cables must be connected to negative (-) battery terminals/posts. Failure to connect your battery harnesses in the proper manner may result in personal injury and/or damage to your scooter. REPLACE cables immediately if damaged.**

### BATTERY DISPOSAL AND RECYCLING

If you encounter a damaged or cracked battery, immediately enclose it in a plastic bag and call your authorised Pride Dealer for instructions on disposal. Your authorised Pride Dealer will also have the necessary information on battery recycling, which is our recommended course of action.

## II. SAFETY

### MOTOR VEHICLE TRANSPORT

Currently, there are no standards approved for tie-down systems in a moving vehicle of any type to transport a person while seated in a scooter.

Although your scooter may be equipped with a positioning belt, this belt is not designed to provide proper restraint during motor vehicle transport. Anyone traveling in a motor vehicle should be properly secured in the motor vehicle seat with safety belts fastened securely.



**WARNING! Do not sit on your scooter while it is in a moving vehicle. Personal injury and/or property damage may result.**

**WARNING! Always be sure your scooter and its batteries are properly secured when it is being transported. Failure to do so may result in personal injury and/or damage to your scooter.**

### PREVENTING UNINTENDED MOVEMENT



**WARNING! If you anticipate being seated in a stationary position for an extended period of time, turn off the power. This will prevent unexpected motion from inadvertent throttle control lever contact. Failure to do so may result in personal injury.**

### GETTING ONTO AND OFF OF YOUR SCOOTER

Getting onto and off of your scooter requires a good sense of balance. Please observe the following safety tips when getting onto and off of your scooter:

- Remove the key from the key switch.
- Ensure that your scooter is not in freewheel mode. See IV. “Your Scooter.”
- Make certain that the seat is locked into place and the key is removed from the key switch.
- The seat armrests can be flipped up to make getting onto and off of the scooter easier.



**WARNING! Position yourself as far back as possible in the scooter seat to prevent the scooter from tipping and causing injury.**

**WARNING! Avoid using your armrests for weight bearing purposes. Such use may cause the scooter to tip and cause personal injury.**

**WARNING! Avoid putting all of your weight on the floorboard. Such use may cause the scooter to tip and cause personal injury.**

### REACHING AND BENDING

Avoid reaching or bending while driving your scooter. When reaching, bending, or leaning while seated on your scooter, it is important to maintain a stable center of gravity and keep the scooter from tipping. Pride recommends that the scooter user determine his/her personal limitations and practice bending and reaching in the presence of a qualified healthcare professional.



**WARNING! Do not bend, lean, or reach for objects if you have to pick them up from the floor by reaching down between your knees. Movements such as these may change your center of gravity and the weight distribution of the scooter and cause your scooter to tip, possibly resulting in personal injury. Keep your hands away from the tyres when driving.**

## II. SAFETY

### POSITIONING BELTS

Your authorised Pride Dealer, therapist(s), and other healthcare professionals are responsible for determining your requirement for a positioning belt in order to operate your scooter safely.



**WARNING! If you require a positioning belt to safely operate your scooter, make sure it is fastened securely. Serious personal injury may result if you fall from the scooter.**

### PRESCRIPTION DRUGS/PHYSICAL LIMITATIONS

The scooter user must exercise care and common sense when operating his/her scooter. This includes awareness of safety issues when taking prescribed or over-the-counter drugs or when the user has specific physical limitations.



**WARNING! Consult your physician if you are taking prescribed or over-the-counter medication or if you have certain physical limitations. Some medications and limitations may impair your ability to operate your scooter in a safe manner.**

### ALCOHOL

The scooter user must exercise care and common sense when operating his/her scooter. This includes awareness of safety issues while under the influence of alcohol.



**WARNING! Do not operate your scooter while you are under the influence of alcohol, as this may impair your ability to drive safely.**

### ELECTROMAGNETIC FIELDS

Your scooter's road performance features may be influenced by electromagnetic fields caused by cellular telephones or other radiating devices, such as hand-held radios, radio and television stations, wireless computer links, microwave sources, and paging transmitters.



**WARNING! You should turn off your scooter when using products which emit electromagnetic fields. This will eliminate the possibility of unintended movement caused by electromagnetic sources. Failure to take this precaution may result in personal injury.**

**WARNING! Your scooter may be a source of electromagnetic and radio frequency interference. Be aware that your scooter may effect the performance of alarm systems and other radiating devices.**



# III. SPECIFICATIONS

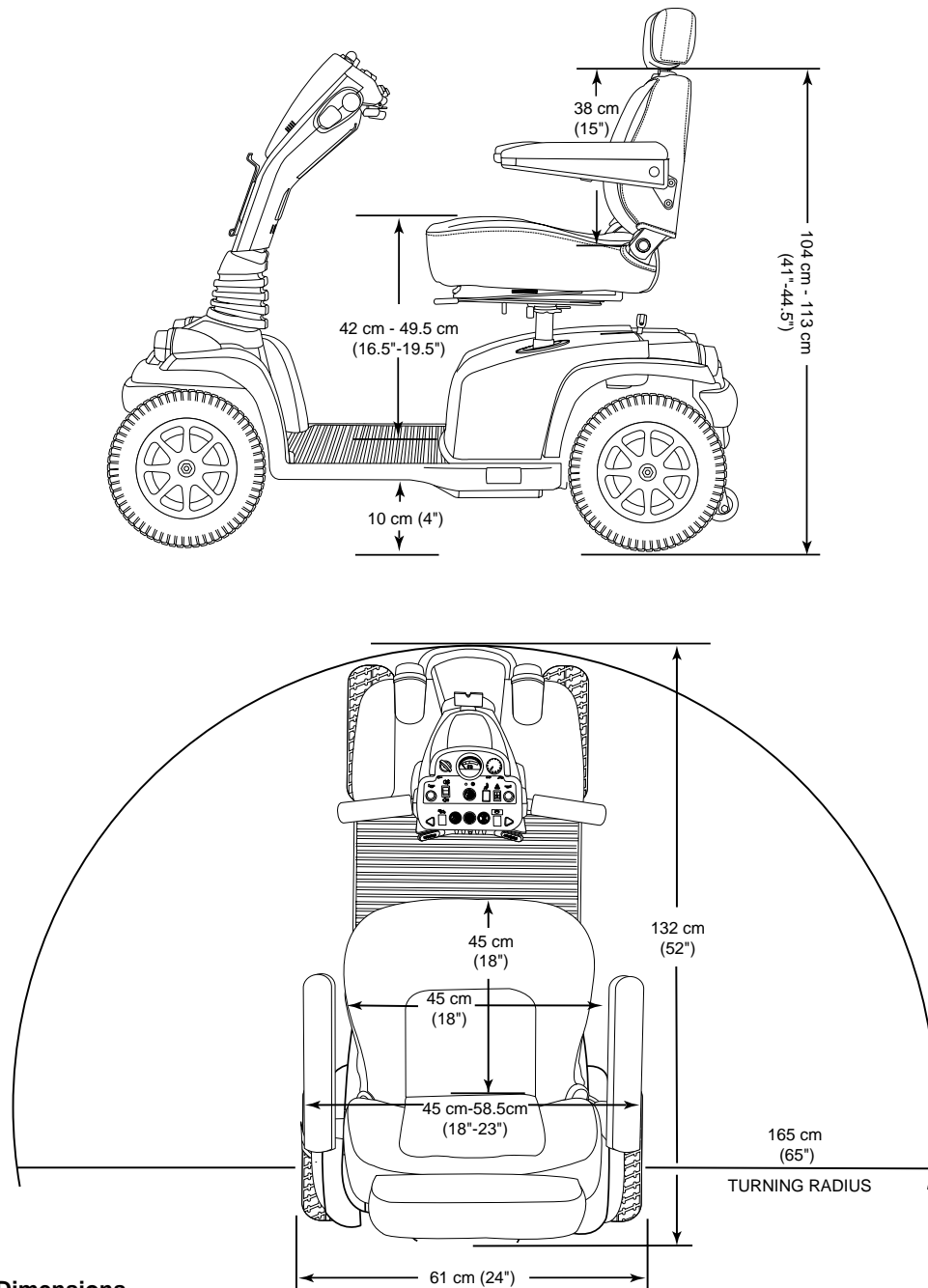

Figure 4. Legend XL Dimensions

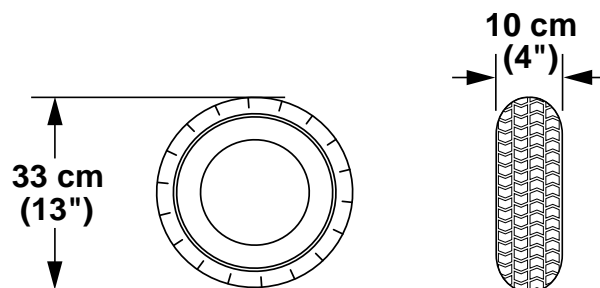

Figure 4A. Legend XL Tyre Dimensions (Front And Rear)

## III. SPECIFICATIONS

|  |  |
|--|--|
| <b>Model Number</b>                      | SCUK3450   |
| <b>Class Of Use</b>                      | C  |
| <b>Maximum Safe Slope</b>                | See figure 1   |
| <b>Maximum Climbing Ability</b>          | See figure 1   |
| <b>Maximum Obstacle Climbing Ability</b> | 5cm (2 in.)  |
| <b>Colours</b>                           | Red, Blue, Champagne, Green  |
| <b>Overall Length</b>                    | 132 cm (52 in.)  |
| <b>Overall Width</b>                     | 61 cm (24 in.)   |
| <b>Total Weight</b>                      | 128 kg (283 lbs.)  |
| <b>Total Weight Without Batteries</b>    | 94 kg (207 lbs.)   |
| <b>Battery Weight (NF-22)</b>            | 17 kg (38 lbs.) each   |
| <b>Heaviest Piece When Disassembled</b>  | Rear section: 37 kg (82 lbs.)  |
| <b>Turning Radius</b>                    | 165 cm (65 in.)  |
| <b>Speed (Maximum)</b>                   | Class 2: Up to 6.5 km/h (4 mph)<br>Class 3: Up to 13 km/h (8 mph)  |
| <b>Range Per Charge*</b>                 | (With NF-22 batteries) Up to 48 km (30 miles)  |
| <b>Ground Clearance</b>                  | 10 cm (4 in.)  |
| <b>Weight Capacity</b>                   | 181 kg (400 lbs.)  |
| <b>Standard Seating</b>                  | Type: Foldable<br>Weight: 19 kg (42 lbs.)<br>Material: Grey Vinyl<br>Dimensions: 45 cm (18 in.) width<br>45 cm (18 in.) depth (usable)<br>38 cm (15 in.) height (usable), 56-66 cm (22-26 in.) with headrest |
| <b>Drive System</b>                      | Rear-wheel drive, sealed mini transaxle, 24 volt DC motor  |
| <b>Dual Braking System</b>               | Electronic, regenerative, and electromechanical  |
| <b>Tyres</b>                             | Type: pneumatic<br>Front and rear: 10 cm x 33 cm (4 in. x 13 in.)  |
| <b>Battery Requirements</b>              | Type: two 12 volt, deep cycle, AGM or Gel-Cell<br>Size: 55 AH, NF-22   |
| <b>Battery Charger</b>                   | 6-amp, onboard Hampton charger   |
| <b>Warranty</b>                          | 2-year limited   |

\* Varies with user weight, terrain type, battery charge, battery condition, and tyre condition.

# IV. YOUR SCOOTER

## TILLER CONSOLE

The tiller console houses all of the controls needed to drive your scooter, including the speed adjustment dial, throttle control levers, battery condition meter, lights switch, hazard lights switch, turn indicator buttons, status LED, and horn buttons. See figure 5.



**WARNING! Do not expose the tiller console to moisture. In the event that the tiller console does become exposed to moisture, do not attempt to operate your scooter until the tiller console has dried thoroughly.**

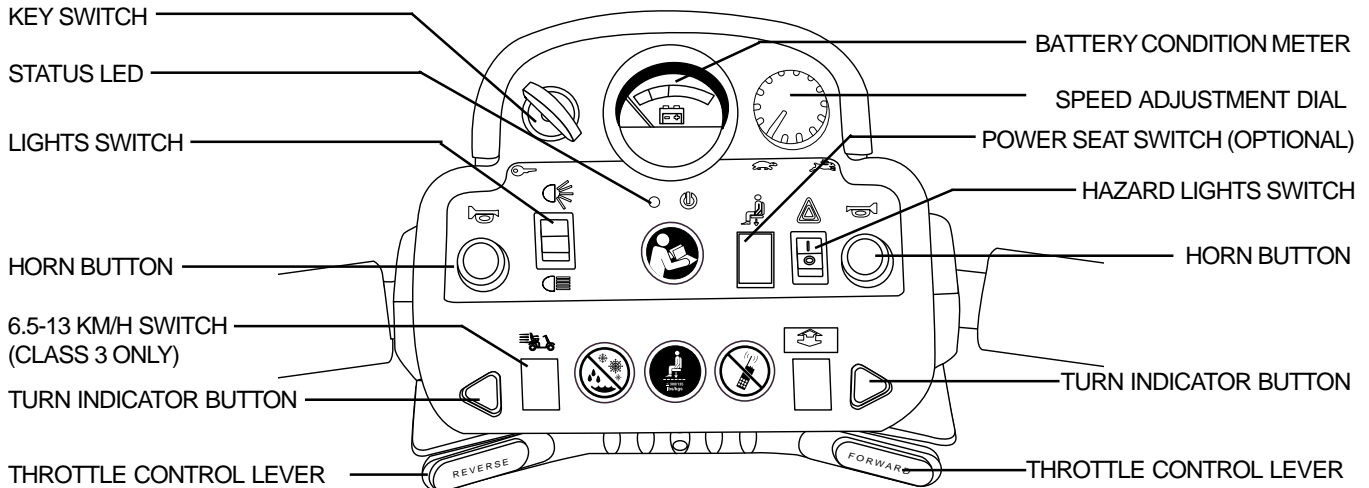

Figure 5. Tiller Console

### Battery Condition Meter

When the key is fully inserted and turned clockwise to power up your scooter, this meter indicates the approximate battery voltage strength. For further information on battery charging, see V. “Batteries and Charging.”

### Turn Indicator Buttons

- Press the appropriate turn indicator button once to activate it.
- Your scooter’s turn indicators are timed to shut off automatically.

### Hazard Lights Switch

This switch activates the 4-way flashers on your scooter.

- Toggle the switch forward to turn on the flashers.
- Toggle the switch rearward to turn off the flashers.

### Horn Button

Your scooter must be turned on for the horn to be operational.

- This button activates a warning horn.
- Do not hesitate to use the warning horn when doing so may prevent accident or injury.

### 6.5-13 km/h (4-8 mph) Switch (Class 3 Only)

- Toggle the switch forward and your scooter’s maximum speed is 13 km/h.
- Toggle the switch rearward and your scooter’s maximum speed is 6.5 km/h.

# IV. YOUR SCOOTER

## Key Switch



**WARNING! If the key is moved to the “off” position while your scooter is in motion, the electronic brakes engage and your scooter will come to an abrupt stop!**

- Insert the key into the key switch and turn it clockwise to power up (turn on) your scooter.
- Turn the key anticlockwise to power down (turn off) your scooter.

## Status LED

The status LED alerts you to electrical problems that may occur with the scooter. The LED remains constantly lit while your scooter is on. If your scooter develops an electrical problem, the status LED will flash a code. See IX. “Basic Troubleshooting” for flash codes.

## Lights Switch

This switch controls your scooter’s lights.

- Toggle the switch forward to turn on your scooter’s rear running lights and front (upper) light.
- Toggle the switch to the middle to turn off the scooter’s lights.
- Toggle the switch rearward to turn on your scooter’s rear running lights, front (upper) and front (lower) lights.



**WARNING! Scooter users are required to use their lights when visibility is restricted—day or night. Failure to use the lighting system in periods of poor visibility may result in personal injury.**

## Speed Adjustment Dial

This dial allows you to preselect and limit your scooter’s top speed.

- The image of the tortoise represents the slowest speed setting.
- The image of the hare represents the fastest speed setting.

## Turn Indicator Buttons

- Press the appropriate turn indicator button once to activate it.
- Your scooter’s turn indicators are timed to shut off automatically.

## Throttle Control Levers

These levers allow you to control the forward speed and the reverse speed of your scooter up to the maximum speed you preset with the speed adjustment dial.

- Place your right hand on the right handgrip and your left hand on the left handgrip.
- Use your right thumb to push the right side of the lever to disengage your scooter’s brakes and move forward.
- Release the lever and allow your scooter to come to a complete stop before pushing the other side of the lever to move in reverse.
- When the throttle control lever is completely released, it automatically returns to the center “stop” position and engages your scooter’s brakes.

# IV. YOUR SCOOTER

## Tiller Console Fuses

These fuses help protect your scooter's front lighting, turn indicators, and key switch console systems from receiving an overload of electrical current. The fuses used in your scooter are the same type used in automobiles. See figure 5A. See X. "Care and Maintenance" for fuse replacement.

## REAR SECTION

The onboard battery charger (not shown), the charger power lead receptacle, the batteries (not shown), the main circuit breaker (reset button), the ammeter, the manual freewheel lever, the anti-tip wheels, and the motor/transaxle assembly (not shown) are located on the rear section of your scooter. See figure 6.

## Ammeter

During charging, the ammeter indicates the charging rate, or how hard the charger is working to charge the scooter's batteries. See V. "Batteries and Charging."

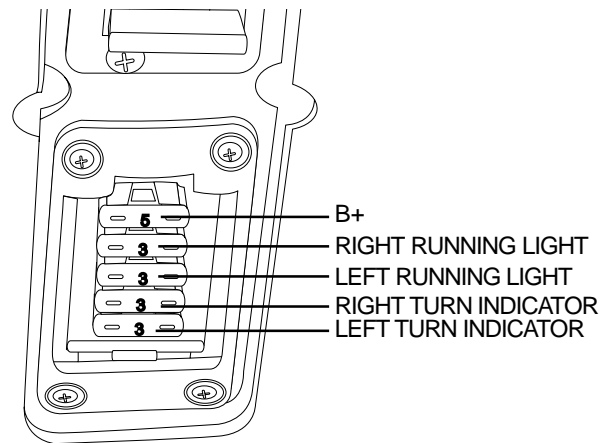

Figure 5A. Tiller Console Fuses

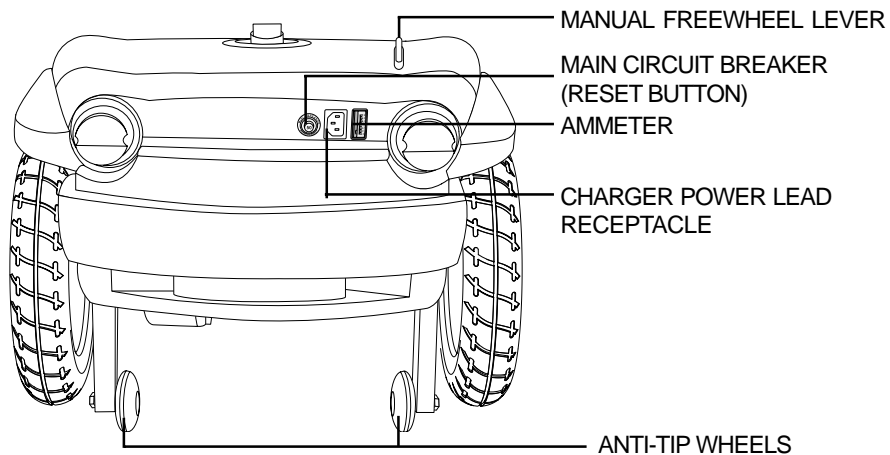

Figure 6. Rear Section

## Anti-Tip Wheels

The anti-tip wheels are an integral and important safety feature of your scooter. Do not, under any circumstances, remove the anti-tip wheels from your scooter.



**WARNING! Do not remove the anti-tip wheels or modify your scooter in any way that is not authorised by Pride.**

**WARNING! The anti-tip wheels are bolted to the scooter frame and may cause trouble when ascending or descending a curb.**

## Batteries (Not Shown)

The batteries store electrical energy that powers your scooter. See V. "Batteries and Charging" for information on how to charge your scooter batteries.

# IV. YOUR SCOOTER

## Manual Freewheel Lever

Whenever you need or want to push your scooter for short distances, you can put it in freewheel mode.

- Remove the key from the key switch.
- Pull up on the manual freewheel lever to disable the drive system and the brake system.
- You may now push your scooter.
- Push down on the manual freewheel lever to reengage the drive and the brake systems and take your scooter out of freewheel mode.



**WARNING! When your scooter is in freewheel mode, the braking system is disengaged.**

- **Disengage the drive motors only on a level surface.**
- **Ensure the key is removed from the key switch.**
- **Stand behind the scooter to engage or disengage freewheel mode. Never sit on a scooter to do this.**
- **After you have finished pushing your scooter, always return it to the drive mode to lock the brakes.**

**Failure to heed the above could result in personal injury and/or damage to your scooter.**



**NOTE: If the scooter is placed in freewheel mode (manual freewheel lever pulled up) while the key is in the “on” position, the scooter will not run until the manual freewheel lever is pushed down and the key is turned to the “off” position, then back to the “on” position.**

## Main Circuit Breaker (Reset Button)

When the voltage in the batteries becomes low or your scooter is heavily strained because of excessive loads, the main circuit breaker may trip to protect the motor and electronics from damage. When the breaker trips, the entire electrical system shuts down.

- The main circuit breaker reset button is located next to the ammeter. See figure 6.
- The reset button pops out when the breaker trips.
- Allow a minute or so for the electronics to “rest.”
- Push in the reset button to reset the breaker.
- If the breaker trips frequently, you may need to charge the batteries more often or have your authorised Pride Dealer perform a load test on the batteries.

## Motor/Transaxle Assembly (Not Shown)

The motor/transaxle assembly is an electromechanical unit that converts electrical energy from your scooter’s batteries into the controlled mechanical energy that drives the scooter’s wheels.

# V. BATTERIES AND CHARGING

Your scooter requires two long-lasting, 12-volt, deep-cycle batteries that are sealed and maintenance free. They are recharged by an onboard charging system.

- Charge your scooter's batteries prior to using it for the first time.
- Keep the batteries fully charged to keep your scooter running smoothly.

## READING YOUR BATTERY VOLTAGE

The battery condition meter on the tiller console indicates the approximate strength of your batteries using a colour code. See figure 7. Green indicates fully charged batteries, yellow a draining charge, and red indicates that an immediate recharge is necessary.



**NOTE: To ensure the highest accuracy, the battery condition meter should be checked while operating your scooter at full speed on a dry, level surface.**

You can also check the charging status of the batteries by the ammeter, located at the rear of the scooter. The charger power lead must be plugged into a standard wall outlet in order to obtain a reading. When the amperage reading is at or near zero amps, charging is complete. See figure 8.

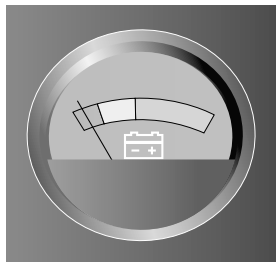
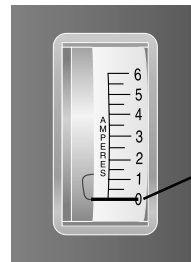

Figure 7. Battery Condition Meter



INDICATES BATTERIES ARE FULLY CHARGED

Figure 8. Ammeter

## CHARGING YOUR BATTERIES

Follow these easy steps to charge your batteries safely:

1. Position your scooter close to a standard wall outlet.
2. Remove the key from the key switch.
3. Make certain that the manual freewheel lever is in the drive (down) position.



**WARNING! Never use an extension lead to plug in your battery charger. Plug the charger directly into a properly wired standard wall outlet.**

4. Plug the charger power lead into the charger power lead receptacle on your scooter.



**NOTE: We recommend that you charge the batteries for 8 to 14 hours. As the batteries charge, the ammeter will slowly drop to zero. When the batteries are fully charged, the needle will vibrate on or about the zero (0) point on the meter scale.**

5. When the batteries are fully charged, unplug the charger power lead from the wall outlet and then from the charger power lead receptacle.



**NOTE: There is a charger inhibit function on your scooter. The scooter will not run and the battery condition meter will not operate while the batteries are charging.**

# V. BATTERIES AND CHARGING

## FREQUENTLY ASKED QUESTIONS (FAQS)

### **How does the charger work?**

When your scooter's battery voltage is low, the charger works harder, sending more electrical current to the batteries to bring up their charge. As the batteries approach a full charge, the charger sends less and less electrical current. When the batteries are fully charged, the current sent from the charger is at nearly zero amperage. Therefore, when the charger is plugged in, it maintains the charge on your scooter's batteries, but does not overcharge them. We do not recommend that you charge your scooter's batteries for more than 24 consecutive hours.

### **What if my scooter's batteries won't charge?**

- Ensure the red (+) and black (-) battery cables are connected properly to the battery terminals.
- Ensure both battery harnesses that extend from the batteries are plugged into their mating harness leading to the charger.
- Ensure both ends of the charger power lead are inserted fully.

### **Can I use a different charger?**

For the safest, most efficient, and balanced charging of your scooter's batteries, we prefer and highly recommend simultaneous charging of both batteries with the onboard battery charger.

### **How often must I charge the batteries?**

Two major factors must be considered when deciding how often to charge your scooter's batteries:

- All day scooter use on a daily basis.
- Infrequent or sporadic scooter use.

With these considerations in mind, you can determine how often and for how long you should charge your scooter's batteries. We designed the onboard charger so that it will not overcharge your scooter's batteries. However, you may encounter some problems if you do not charge your batteries often enough and if you do not charge them on a regular basis. Following the guidelines below will provide safe and reliable battery operation and charging.

- If you use your scooter daily, charge its batteries as soon as you finish using it for the day. Your scooter will be ready each morning to give you a full day of service. We recommend that you charge your scooter's batteries for 8 to 14 hours after daily use.
- If you use your scooter once a week or less, charge its batteries at least once a week for 12 to 14 hours at a time.
- Keep your scooter's batteries fully charged.
- Avoid deeply discharging your scooter's batteries.

### **How can I ensure maximum battery life?**

Fully charged deep-cycle batteries provide reliable performance and extended battery life. Keep your scooter's batteries fully charged whenever possible. Batteries that are regularly and deeply discharged, infrequently charged, or stored without a full charge may be permanently damaged, causing unreliable performance and limited service life.



# V. BATTERIES AND CHARGING

## How can I get maximum range or distance per charge?

Rarely will you have ideal driving conditions—smooth, flat, hard driving surfaces with no wind or curves. Often, you will face hills, pavement cracks, uneven and loosely packed surfaces, curves, and wind, all of which affect the distance or running time per battery charge. Below are a few suggestions for obtaining the maximum range per battery charge.

- Always fully charge your scooter's batteries prior to daily use.
- Maintain **30-35 psi (2-2.5 bar)** in each tyre.
- Plan your route ahead to avoid as many hills, cracked, broken, or soft surfaces as possible.
- Limit your baggage weight to essential items.
- Try to maintain an even speed while your scooter is in motion.
- Avoid stop-and-go driving.

## What type and size of battery should I use?

We recommend deep-cycle batteries that are sealed and maintenance free. Both AGM and Gel Cell are deep-cycle batteries that are similar in performance. Do not use wet-cell batteries, which have removable caps.



**WARNING! Corrosive chemicals are contained in batteries. Use only AGM or Gel-Cell batteries to reduce the risk of leakage or explosive conditions.**



**NOTE: Sealed batteries are not serviceable. Do not remove the caps.**

## BATTERY SPECIFICATIONS

|                  |                              |
|------------------|------------------------------|
| <b>Type:</b>     | Deep-cycle (AGM or Gel-Cell) |
| <b>Size:</b>     | NF-22                        |
| <b>Voltage:</b>  | 12 volts each                |
| <b>Amperage:</b> | 55 AH                        |

To change a battery in your scooter:



**WARNING! Battery posts, terminals, and related accessories contain lead and lead compounds. Wash hands after handling.**

1. Remove the seat and rear shroud.
2. Disconnect the battery tie-down strap.
3. Disconnect the T-handle battery harness.
4. Disconnect the battery cables from the battery terminals.
5. Remove the old battery.
6. Place a new battery in the battery well.
7. Connect the red battery cable to the positive (+) battery terminal.
8. Connect the black battery cable to the negative (-) battery terminal.
9. Reconnect the T-handle battery harness.
10. Reconnect the battery tie-down strap.
11. Reinstall the rear shroud and seat.

## BATTERY DISPOSAL AND RECYCLING

If you encounter a damaged or cracked battery, immediately enclose it in a plastic bag and call your authorised Pride Dealer for instructions on disposal. Your authorised Pride Dealer will also have the necessary information on battery recycling, which is our recommended course of action.

## V. BATTERIES AND CHARGING

### **Why do my new batteries seem weak?**

Deep-cycle batteries employ a different chemical technology than that used in car batteries, nickel-cadmium batteries (nicads), and other common battery types. Deep-cycle batteries are specifically designed to provide power, drain down their charge, and then accept a relatively quick recharge.

We work closely with our battery manufacturer to provide batteries that best suit your scooter's specific electrical demands. Fresh batteries arrive daily at Pride and are shipped fully charged to our customers. During shipping, the batteries may encounter temperature extremes that can influence their initial performance. Heat diminishes the charge on the battery; cold slows the available power and extends the time needed to recharge the battery.

It may take a few days for the temperature of your scooter's batteries to stabilise and adjust to their new room or ambient temperature.

More importantly, it takes a few charging cycles (partial draining followed by full recharging) to establish the critical chemical balance that is essential to a deep-cycle battery's peak performance and long life.

Follow these steps to properly break in your scooter's new batteries for maximum efficiency and service life.

1. Fully recharge any new battery prior to its initial use. This charging cycle brings the battery up to about 88% of its peak performance level.
2. Operate your new scooter in familiar and safe areas. Drive slowly at first, and do not travel too far from your home or familiar surroundings until you have become accustomed to your scooter's controls and have properly broken in your scooter's batteries.
3. Fully recharge the batteries. They should be at over 90% of their peak performance level.
4. Operate your scooter again.
5. Fully recharge the batteries again.
6. After four or five charging cycles, the batteries are able to receive a charge of 100% of their peak performance level and are able to last for an extended period of time.

### **How should I store my scooter's batteries?**

See X. "Care and Maintenance."

### **What about public transportation?**

If you intend to use public transportation with your scooter, you must contact the transportation provider in advance to determine their specific requirements.

# VI. OPERATION

## BEFORE GETTING ON YOUR SCOOTER

- Have you fully charged the batteries? See V. “Batteries and Charging.”
- Is the manual freewheel lever in the drive (down) position? Never leave the manual freewheel lever pulled up unless you are manually pushing your scooter.

## GETTING ONTO YOUR SCOOTER

1. Make certain that the key is removed from the key switch.



**WARNING! Never attempt to board or exit your scooter without first removing the key from the key switch. This will prevent the scooter from moving if accidental throttle control lever contact is made.**

2. Stand at the side of your scooter.
3. Disengage the seat lock lever and rotate the seat until it is facing you.
4. Make certain that the seat is locked securely in position.
5. Position yourself comfortably and securely in the seat.
6. Disengage the seat lock lever and rotate the seat until you are facing forward.
7. Make certain that the seat is locked securely in position.
8. Make certain that your feet are safely on the floorboard.

## PRE-RIDE ADJUSTMENTS AND CHECKS

- Are you positioned comfortably in the seat? See “Getting Onto Your Scooter,” above.
- Is the seat at the proper height? See VII. “Comfort Adjustments.”
- Is the seat locked securely in place? See VII. “Comfort Adjustments.”
- Is the tiller at a comfortable setting and locked securely in place? See VII. “Comfort Adjustments.”
- Is the key fully inserted into the key switch and turned clockwise to the “on” position? See IV. “Your Scooter.”
- Does the scooter’s horn work properly?
- Is your proposed path clear of people, pets, and obstacles?
- Have you planned your route to avoid adverse terrain and as many inclines as possible?

## OPERATING YOUR SCOOTER

Keep both hands on the tiller and your feet on the floorboard at all times while operating your scooter. This driving position gives you the most control over your vehicle.

- Set the speed adjustment dial to your desired speed.
- Press your thumb against the appropriate throttle control lever.
- The electromechanical disc park brake automatically disengages and the scooter accelerates smoothly to the speed you preselected with the speed adjustment dial.
- Pull on the left handgrip to steer your scooter to the left.
- Pull on the right handgrip to steer your scooter to the right.
- Move the tiller to the center position to drive straight ahead.
- To stop, slowly release the throttle control lever. After you release the throttle control lever, gently squeeze the hand brake (if equipped) to come to a complete stop. The electronic brakes will automatically engage when your scooter comes to a stop.



**NOTE: Your scooter’s reverse speed is slower than that of the forward speed you preset with the speed adjustment dial.**

# VI. OPERATION

## GETTING OFF OF YOUR SCOOTER

1. Bring your scooter to a complete stop.
2. **Remove the key from the key switch.**
3. Disengage the seat lock lever and rotate the seat until you are facing toward the side of your scooter.
4. Make certain that the seat is locked securely in position.
5. Carefully and safely get out of the seat and stand to the side of your scooter.
6. You can leave the seat facing to the side to facilitate boarding your scooter next time.

## POWER DOWN TIMER FEATURE

Your scooter is equipped with an energy saving automatic power down timer feature designed to preserve your scooter's battery life. If you mistakenly leave the key in the key switch and in the "on" position but do not use your scooter for approximately 20 minutes, the scooter's controller shuts down automatically. Although the controller is shut down, power will still be supplied to the scooter's lighting system.

If the power down timer feature takes effect, perform the following steps to resume normal operation.

1. Turn the key to the "off" position.
2. Turn the key back to the "on" position.

# VII. COMFORT ADJUSTMENTS



**WARNING! Remove the key from the key switch before adjusting the tiller or the seat. Never attempt to adjust the tiller or the seat while the scooter is in motion.**

## TILLER ANGLE ADJUSTMENT

Your scooter is equipped with a pivoting tiller that allows adjustment to several positions from the scooter deck to the farthest forward stop.

1. Lift the tiller adjustment lever. See figure 9.
2. Move the tiller to a comfortable position.
3. Release the tiller adjustment lever to secure the tiller in position.

TILLER ADJUSTMENT  
LEVER

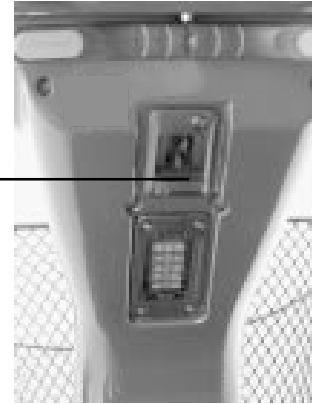

Figure 9. Tiller Adjustment

## SEAT ROTATION

The seat lock lever will lock the seat into several positions.

1. Push forward on the seat lock lever to unlock the seat. See figure 10.
2. Rotate the seat to the desired position.
3. Pull back firmly on the seat lock lever to lock the seat securely in place.

SEAT SLIDING LEVER

SEAT LOCK LEVER

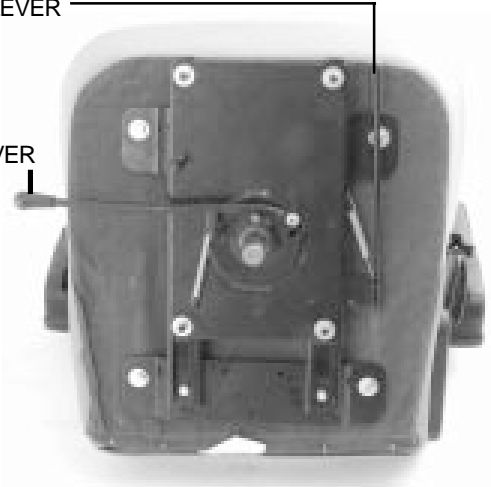

Figure 10. Seat Adjustment

## FRONT-TO-BACK SEAT ADJUSTMENT

You can reposition the scooter's seat forward or rearward to adjust the distance between the seat and the tiller. See figure 10.

1. Move the seat sliding lever outward.
2. While holding the lever out, slide the seat forward or rearward.
3. Release the seat sliding lever once the seat is in the desired position.

## SEATBACK ADJUSTMENT



**WARNING! Do not operate your scooter with the seatback in a reclined position.**

**WARNING! Always keep your back pressed firmly against the seatback while adjusting the angle.**

To adjust your scooter's reclining seat, perform these steps. See figure 11.

1. With your back pressed up against the seatback, lift up on the seatback adjustment lever and lean forward or rearward to adjust the seatback angle.
2. Release the seatback adjustment lever once the seat is in a comfortable riding position.

SEATBACK ADJUSTMENT  
LEVER



Figure 11. Seatback Adjustment

# VII. COMFORT ADJUSTMENTS

## ARMREST ANGLE ADJUSTMENT

The armrest angle of your scooter can be adjusted upward or downward. See figure 12.

- By turning the adjustment dial, the armrest angle will either raise or lower.



**NOTE: The armrests also pivot upward to make getting on and off of your scooter easier.**

## SEAT HEIGHT ADJUSTMENT

You can change the seat height to one of three positions in 2.5 cm (1 in.) increments.

### Changing the seat height:

1. Turn the scooter off and place the manual freewheel lever in drive mode.
2. Lift the seat up and out of the seat post.
3. Loosen and remove the seat height adjustment bolt and bolt-nut.
5. Slide the upper seat post up or down in the lower seat post.
6. Align the adjustment holes on the upper seat post and the lower seat post.
7. Reinstall the seat height adjustment bolt and bolt-nut, then tighten.
8. Reinstall the shroud.
9. Reinstall and lock the seat into place.

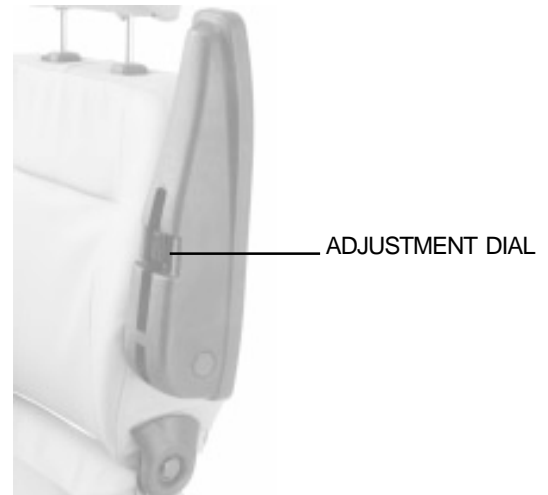

Figure 12. Armrest Angle Adjustment

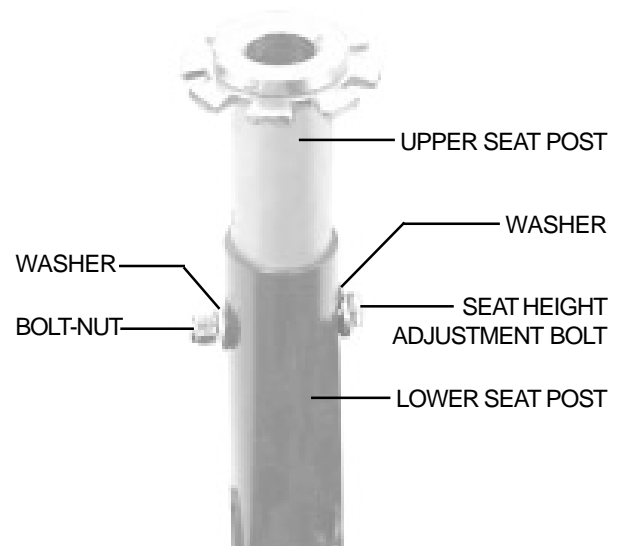

Figure 13. Seat Height Adjustment

## VII. COMFORT ADJUSTMENTS

### POWER SEAT (OPTIONAL)

Your scooter may be equipped with a power seat. The power seat actuator is designed to raise or lower the seat automatically with minimal effort on the part of the operator.

#### Operating your power seat:

1. Ensure your scooter is level and stationary.
2. Toggle “on” the power seat switch that is located on the tiller console.
3. To raise the power seat, place your hands on the handgrips and use your thumb to push the right side of the throttle control lever.
4. Release the lever when you have attained your desired height.
5. To lower the power seat, place your hands on the handgrips and use your thumb to push the left side of the throttle control lever.
6. Release the lever when you have attained your desired height.
7. Ensure your seat is in the lowest position and toggle “off” the power seat switch before you attempt to drive your scooter again.

**WARNING! The power seat is intended for operation only while your scooter is stationary and on a level surface. Its purpose is to aid you in reaching objects.**



**Strict adherence to the following safety rules is vital to your safety:**

- **Do not attempt to raise or lower the seat while in motion!**
- **Operate the power seat only on level ground.**
- **Do not operate your scooter with the power seat elevated.**
- **It is recommended that the scooter be driven only with the seat in the lowest position.**

# VIII. DISASSEMBLY AND ASSEMBLY

## DISASSEMBLY

You can disassemble the scooter into seven pieces: the seat, the front section, the rear section, the rear shroud, the basket, and the batteries. See figure 14. Place the scooter in an area where you have sufficient clearance to move the parts around. You need about 1.5 meters (five feet) in all directions. You may need assistance to lift some of the scooter components.

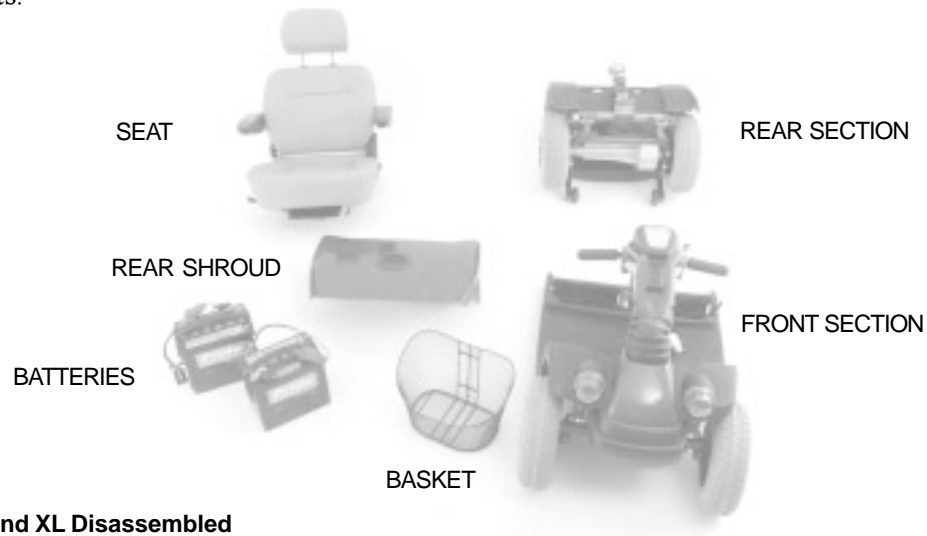

Figure 14. The Legend XL Disassembled

No tools are required to disassemble or assemble your scooter. Always disassemble or assemble your scooter on a level, dry surface with sufficient room for you to work and move around your scooter. Keep in mind that the disassembled sections of the scooter take up more floor space than the assembled scooter.



**WARNING! Lifting weight beyond your physical capability may result in personal injury. Ask for assistance when necessary while disassembling or assembling your scooter.**

1. Place the manual freewheel lever in the drive (down) position.
2. Coil the charger power lead and store it for future use.
3. Lift the seat up and off the scooter.
4. Gently pull the shroud up and off of the rear section of the scooter.
5. Disconnect the battery strap.
6. Unplug both T-handle battery harnesses. See figure 15.
7. Unplug the front-to-rear harness. See figure 15.



**WARNING! Failure to unplug both T-handle battery harnesses and the front-to-rear harness prior to separating the front and rear sections could result in permanent damage to the scooter.**

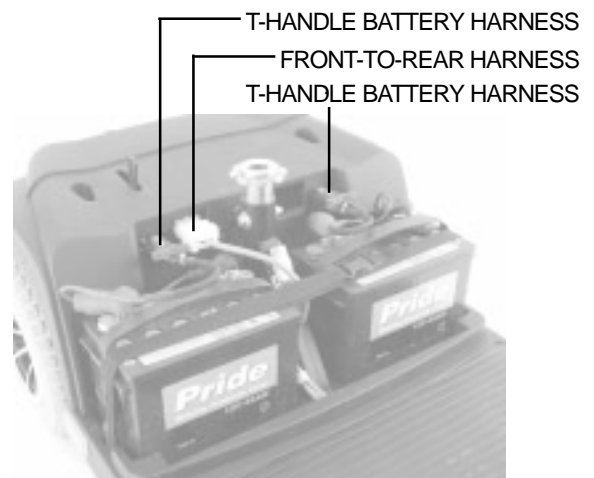

Figure 15. Harness Connections



# VIII. DISASSEMBLY AND ASSEMBLY

## Toggle Latch Release

1. Push in the toggle latch release button while pulling back the toggle latch. See figures 16 and 16A.
2. Position the toggle latch buckle over the top of the toggle latch. See figure 16B.
3. Lower the tiller to the scooter floorboard.

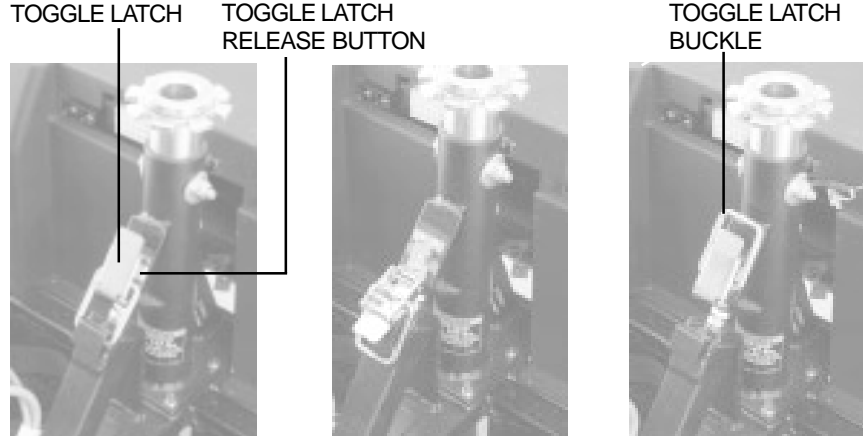

Figure 16. Toggle Latch (Latched)

Figure 16A. Toggle Latch (Unlatched)

Figure 16B. Buckle Secured

## Frame Separation

1. Push back on the seat post to pivot the scooter's rear section rearwards until the rear section is standing vertically on its bumper. See figure 17.
2. Lift the front section up until the lower pegs are no longer in the slots. See figure 18.
3. Carefully move the front section away from the rear section.

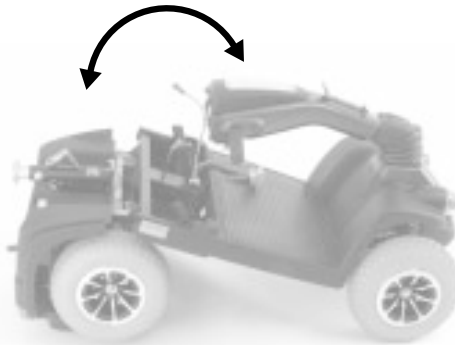

Figure 17. Frame Positioning



Figure 18. Separating The Frame Sections

## ASSEMBLY

1. Position the front and rear sections of your scooter as shown in figure 19.
2. Align the lower slots of the front section with the corresponding pegs on the front of the rear section. See figure 19.



**WARNING! Position the front-to-rear harness cable so it won't become pinched between the frame halves when pivoting the rear section forward. See figure 19.**

3. Holding the seat post, slowly pivot the rear section forward until the curved locking brackets are fully connected onto the top rear pegs. See figure 17.
4. Raise the tiller.
5. Secure the toggle latch. See figure 16A.
  - Lower the toggle latch buckle.
  - Push back on the toggle latch so it locks into place.
6. Connect the front-to-rear harness and both T-handle battery harnesses.
7. Reinstall the shroud.
8. Reinstall the seat, and lock it into place.

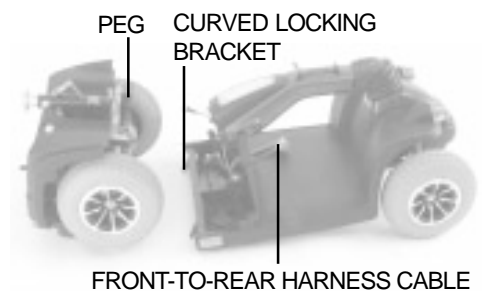

Figure 19. Frame Sections

# IX. BASIC TROUBLESHOOTING

Any electromechanical device occasionally requires some troubleshooting. However, most of the problems that may arise can usually be solved with a bit of thought and common sense. Many of these problems occur because the batteries are not fully charged or because the batteries are worn down and can no longer hold a charge.

## DIAGNOSTIC FLASH CODES

The diagnostic flash codes for your scooter are designed to help you perform basic troubleshooting quickly and easily. A diagnostic flash code will flash from the status LED in the event one of the conditions listed below develops.



**NOTE: Your scooter will not run unless the flash code condition is resolved and the scooter has been turned off then turned back on.**

| FLASH CODE    | CONDITION  | SOLUTION  |
|---------------|--|---|
| (1) ■         | Battery voltage is too low to operate the scooter or the charger is operating.       | Charge batteries or unplug the charger power lead from the electrical outlet.   |
| (2) ■■        | Motor disconnected.  | Check all connections to the motor.   |
| (3) ■■■       | Motor wiring fault.  | Call your authorised Pride Dealer for assistance.   |
| (6) ■■■■■■    | Scooter is operating with the charger attached.                                      | Unplug the charger power lead from the charger power lead receptacle.   |
| (7) ■■■■■■■■  | Throttle potentiometer fault.  | Call your authorised Pride Dealer for assistance.   |
| (8) ■■■■■■■■  | Internal controller fault.   | Call your authorised Pride Dealer for assistance.   |
| (9) ■■■■■■■■  | Brake fault—your scooter was left in freewheel mode.                                 | Turn the scooter key to the “off” position, then push the manual freewheel lever to the (down) drive position, and restart your scooter.                            |
| (10) ■■■■■■■■ | High battery voltage. The batteries have been overcharged and the scooter won't run. | Leave the scooter turned on to drain the batteries to a sufficient level. If the batteries continue to overcharge call your authorised Pride Dealer for assistance. |

### What if all the systems on my scooter seem to be “dead”?

- Make certain that the key is in the “on” position.
- Check that the batteries are fully charged.
- Push in the main circuit breaker reset button. See IV. “Your Scooter .”
- Make certain that both T-handle battery harnesses are firmly connected to the rear section and to the battery terminals. See VIII. “Disassembly and Assembly.”
- Make sure that the front-to-rear harness is firmly connected to the rear section. See VIII. “Disassembly and Assembly.”
- Be sure the power down timer feature hasn't been activated. See VI. “Operation.”
- Check the 3-amp fuse located on the lower portion of the tiller console. See X. “Care and Maintenance” for fuse replacement.

### What if my scooter does not move when I press the throttle control levers?

- When the manual freewheel lever is pulled up, the brakes are disengaged and all power to the motor/transaxle assembly is cut.
- Push down on the manual freewheel lever, turn the scooter off, and then turn the scooter on to return to normal scooter operation.

## IX. BASIC TROUBLESHOOTING

### **What if the main circuit breaker repeatedly trips?**

- Charge the scooter's batteries more frequently. See V. "Batteries and Charging."
- If the problem continues, have both of your scooter's batteries load tested by your authorised Pride Dealer.
- You may also perform the load test yourself. Battery load testers are available at most automotive parts stores.
- Follow the directions supplied with the load tester.
- See V. "Batteries and Charging" or III. "Specifications" for information about your scooter's battery type.

### **What if the battery condition meter dips way down and the motor surges or hesitates when I press my scooter's throttle control lever?**

- Fully charge your scooter's batteries. See V. "Batteries and Charging."
- Have your authorised Pride Dealer load test each battery.
- Or, see the previous troubleshooting question for load testing the batteries yourself.

If you experience any problems with your scooter that you are not able to solve, immediately contact your authorised Pride Dealer for information, maintenance, and service.

# X. CARE AND MAINTENANCE

Your scooter requires a minimal amount of care and maintenance. If you do not feel confident in your ability to perform the maintenance listed below, you may schedule inspection and maintenance at your authorised Pride Dealer. The following areas require periodic inspection and/or care and maintenance.

## TYRE PRESSURE

- If equipped with pneumatic tyres, always maintain a proper **30-35 psi (2-2.5 bar)** tyre pressure.



**WARNING! It is important that 30-35 psi (2-2.5 bar) tyre pressure be maintained in pneumatic tyres at all times. Do not underinflate or overinflate your tyres. Low pressure may result in loss of control, and overinflated tyres may burst. Failure to maintain 30-35 psi (2-2.5 bar) tyre pressure in pneumatic tyres at all times may result in tyre and/or wheel failure, causing serious personal injury and/or damage to your scooter.**

- Regularly inspect your scooter's tyres for signs of wear.

## EXTERIOR SURFACES

Bumpers, tyres, trim, and the tiller boot can benefit from an occasional application of rubber or vinyl conditioner.



**WARNING! Do not use a rubber or vinyl conditioner on the scooter's vinyl seat or tyre tread. They will become dangerously slippery and result in personal injury and/or damage to your scooter.**

## BATTERY TERMINAL CONNECTIONS

- Make certain that the terminal connections remain tight and uncorroded.
- The batteries must sit flat in the battery wells.
- The battery terminals should face the rear of the scooter.

## WIRING HARNESSES

- Regularly check all wiring connections.
- Regularly check all wiring insulation, including the charger power lead, for wear or damage.
- Have your authorised Pride Dealer repair or replace any damaged connector, connection, or insulation that you find before using your scooter again.

## ABS PLASTIC SHROUDS

- The front tiller shroud, front shroud, and the rear shroud are formed from durable ABS plastic and are coated with an advanced formula urethane paint.
- A light application of car wax will help the shrouds retain their high gloss.

## AXLE BEARINGS AND THE MOTOR/TRANSAXLE ASSEMBLY

These items are all prelubricated, sealed, and require no subsequent lubrication.

## MOTOR BRUSHES

The motor brushes are housed inside of the motor transaxle/assembly. They should be inspected periodically for wear by your authorised Pride Dealer.

# X. CARE AND MAINTENANCE

## CONSOLE, CHARGER, AND REAR ELECTRONICS

- Keep these areas free of moisture.
- Allow these areas to dry thoroughly if they have been exposed to moisture before operating your scooter again.

## FUSE REPLACEMENT

In the event a fuse should cease to work:

- Remove the fuse by pulling it out of its slot.
- Examine the fuse to be sure it is blown. See figures 20 and 21.
- Insert a new fuse of the proper rating.

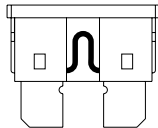

Figure 20. Working Fuse

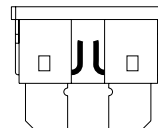

Figure 21. Blown Fuse (Replace)



**WARNING! The replacement fuse must exactly match the rating of the new fuse. Failure to use properly rated fuses may cause damage to the electrical system and may result in personal injury.**

## LIGHT BULB REPLACEMENT

The scooter's light bulbs are easily replaceable. Do not use regular automotive-type 12-volt light bulbs; your scooter is equipped with a 24-volt electrical system. Replacement light bulbs can be purchased from your authorised Pride Dealer.



**NOTE: Use only 24-volt light bulbs.**

- Remove the light cover.
- Gently remove the bulb by pulling it straight out.
- Insert a new bulb of the same wattage.
- Replace the light cover.

## STORING YOUR SCOOTER

If you plan on not using your scooter for an extended period of time, it is best to:

- Fully charge its batteries prior to storage.
- Disconnect the batteries from the scooter.
- Store your scooter in a warm, dry environment.
- Avoid storing your scooter where it will be exposed to temperature extremes.



**WARNING! Always protect batteries from freezing temperatures and never charge a frozen battery. This damages the battery and can cause personal injury.**

For prolonged storage, you may wish to place several boards under the frame of your scooter to raise it off of the ground. This takes the weight off the tyres and reduces the possibility of flat spots developing on the areas of the tyres contacting the ground.

# XI. OPTIONAL ACCESSORIES

## OPTIONAL ACCESSORIES

For information concerning these optional accessories, contact your authorised Pride Dealer.

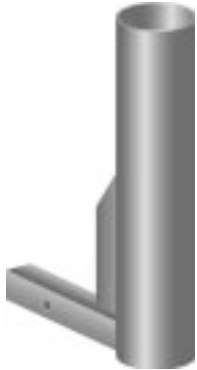

Single Cane/Crutch Holder



Dual Cane/Crutch Holder



Walker Holder



Forearm Crutch Holder



Oxygen Tank Holder



Rear Basket



Cup Holder



Safety Flag

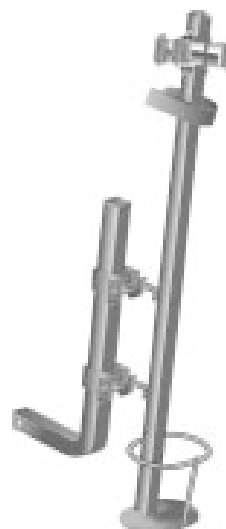

Double Crutch Holder



Quad Cane Holder

## XII. WARRANTY

### **TWO-YEAR LIMITED WARRANTY**

Structural frame components, including: platform, fork, seat post, and frame welds.  
Drive train, including: differential, motor, and brake.

### **ONE-YEAR LIMITED WARRANTY**

Your Pride Scooter is fully guaranteed for twelve (12) months from the date of purchase against faults arising due to defects in manufacture or materials. This warranty does not detract from, but is in addition to your legal rights.

All electronic parts, including controllers and battery chargers, have a one (1) year warranty. Servicing to the controller or battery charger must be carried out by your authorised Pride Dealer. Any attempt to open or dismantle these items renders the guarantee void on that item.

### **NOT COVERED UNDER WARRANTY**

This guarantee does not extend to those items which may need replacement due to normal wear and tear (tyres, belts, bulbs, upholstery, plastic shrouds, motor brushes, fuses, and batteries), or damage to the product caused by misuse or accident for which Pride or its agent cannot be held responsible. This warranty does not include labor or service calls.

### **BATTERIES**

Batteries are covered by a six (6) month warranty from the original manufacturer.

Gradual deterioration in performance due to being left in a discharged state, left in cold conditions for long periods of time, or worn out through heavy use is not covered.

### **SERVICE CHECKS AND WARRANTY SERVICE**

Warranty service can be performed by an authorised Pride Dealer. Please contact your authorised Pride Dealer for advice on the current cost affecting the service visit.

### **REPLACEMENT UNITS**

The availability of replacement units is subject to the discretion of the provider, not the manufacturer. For more information regarding replacement units, contact your authorised Pride Dealer.