

Victory XL-8

Owner's Manual



The Ultimate In Style & Performance

Pride
Mobility Products Ltd.

*Unit 106, Heyford Park Camp Road
Upper Heyford, Oxfordshire OX25 5HA*

www.pridemobility.com

SAFETY GUIDELINES

Read and follow all of the instructions in this manual before you attempt to operate your Scooter for the first time. If you are unable to understand any of this information or require additional assistance for setup, contact your local Pride provider.

The following symbols will be used throughout this owner's manual to identify warnings and cautions. It is very important for you to read and understand them completely.



WARNING! Failure to heed the warnings in this owner's manual may result in personal injury.



CAUTION! Failure to heed the cautions in this owner's manual may result in damage to your Scooter.

Please be sure to fill out and return your warranty card. Also, notify us of any change of address so that we can keep you apprised of important information about safety, new products, and new options that can increase your ability to use and enjoy your Scooter.

Acrobat

Your Scooter:

Body Colour _____

Serial # _____

Purchase Date _____

Options _____

Your authorized Pride provider:

Name _____

Address _____

Phone _____

CONTENTS

I. INTRODUCTION	5
II. SAFETY	6
III. SPECIFICATIONS	10
IV. DESCRIPTION	12
V. BATTERIES AND CHARGING	18
VI. OPERATION	22
VII. COMFORT ADJUSTMENTS	24
VIII. DISASSEMBLY AND ASSEMBLY	26
IX. TROUBLESHOOTING	28
X. CARE AND MAINTENANCE	29
XI. WARRANTY	31



Document

COPYRIGHT

Pride Mobility Products, Ltd., cannot be held responsible for any damage or injury incurred due to improper or unsafe use of a Scooter. Nor can Pride Mobility Products, Ltd., be held responsible for any damage or injury incurred during or resulting from attempts to follow the instructions and recommendations set forth in this owner's manual or in any of the instructions displayed on or accompanying the product itself. If you do not feel capable of safely following any of the instructions and recommendations pertaining to your Scooter, please contact your authorized Pride Mobility Products, Ltd., provider.

I . I N T R O D U C T I O N

Welcome to Pride Mobility Products, Ltd. (Pride). We would like to congratulate you on the purchase of your new Victory XL-8 Scooter. The Victory XL-8 design combines the most advanced state-of-the-art components with modern, attractive styling. We are certain that the design features and trouble-free operation of your new Victory XL-8 Scooter will add convenience to your daily living.

This owner's manual is compiled from the latest specifications and product information available at the time of publication. We reserve the right to make changes as they become necessary. Any changes to our products may cause slight variations between the illustrations and explanations in this manual and the product you purchased.

As an owner of a Pride product, you are invited to submit your warranty registration and enroll in the Pride Owner's Club. As a registered member, you will have access to product information, special offers, interviews, stories, and interactive message boards — all available to Pride Owners Club members only. For more information, you can access our web site by signing on to www.pridemobility.com. Click on the Owners Club icon and follow the prompts.

Pride cannot be held responsible for any damage or injury incurred due to improper or unsafe use of a Victory XL-8 Scooter. Nor can Pride be held responsible for any damage or injury incurred during or resulting from attempts to follow the instructions and recommendations set forth in this owner's manual or in any of the instructions displayed on or accompanying the product itself. If you do not feel capable of safely following any of the instructions and recommendations pertaining to your Victory XL-8 Scooter, please contact your authorized Pride provider.

We want to hear your questions, comments, and suggestions about this manual. We would also like to hear about the safety and reliability of your new Victory XL-8 Scooter, as well as about the service you received from your Pride provider. Please feel free to write us at the address below:

Pride Mobility Products, Ltd.
Unit 106, Heyford Park Camp Road
Upper Heyford, Oxfordshire OX25 5HA

Please be sure to fill out and return your warranty card. Also, notify us of any change of address so that we can keep you apprised of important information about safety, new products, and new options that can increase your ability to use and enjoy your Victory XL-8 Scooter.

At Pride, your safety is important to us. Please read and follow all of the instructions in this manual before you attempt to operate your Scooter for the first time. These instructions were produced for your benefit. Your understanding of these instructions is essential for the safe operation of your new Victory XL-8.

If you experience any problems with your Scooter that you are not able to solve, or if you do not feel confident in your ability to perform any of the instructions contained in this manual, please contact your local Pride provider. Once you understand how to operate and take care of your Victory XL-8, we are certain that it will give you years of trouble-free service and enjoyment.

The Pride Team

II. SAFETY

You must read this entire manual and understand all of the safety precautions before you attempt to operate your new Victory XL-8 for the first time.

SAFETY PRECAUTIONS

WARNING! Do not operate your Scooter in icy or slippery conditions or on salted surfaces (i.e., walks or roads). Such use may result in an accident, personal injury, or adversely affect the performance and/or safety of your Scooter.

WARNING! Do not operate or store your Scooter where it may be exposed to inclement weather conditions such as rain, snow, mist, and below-freezing temperatures (such as storage on an outside car/van lift). Attempting to operate the Scooter in such conditions can damage the electronics and potentially result in loss of control.

WARNING! Do not operate your Scooter where you cannot safely and legally walk. Use extreme caution when driving on busy streets, in parking lots, or in shopping malls. Always assume that you cannot be seen by motor vehicle drivers.

WARNING! Lock your seat into place and remove the key from the key switch before you get on or off of your Scooter.

WARNING! Lock the Scooter seat into position before you operate your Scooter.

WARNING! Do not operate your Scooter with the seat in the reclined position (if so equipped).



WARNING! Make certain that the tyres are properly inflated (30 psi).

WARNING! Do not operate your Scooter while you are under the influence of alcohol. Operating powered vehicles while you are under the influence of alcohol impairs your ability to operate the Scooter in a safe manner and may violate certain existing laws.

WARNING! Do not operate your Scooter without first consulting your physician about any concerns you have about physical limitations that could prevent you from safely operating your Scooter.

WARNING! Do not operate your Scooter if you are taking medication which may impair your ability to operate the Scooter in a safe manner.

WARNING! Do not drive your Scooter across the side of a hill or diagonally up or down a hill; do not stop, if possible, while driving up or down an incline.

WARNING! Keep both hands on the tiller and your feet on the floorboard at all times while operating your Scooter. This driving position gives you the most control over your vehicle.

WARNING! Proceed with extreme caution when driving near raised surfaces or unprotected ledges or drop-offs (kerbs, porches, stairs, etc.).

WARNING! Drive slowly through turns.

WARNING! Do not use your Scooter as a seat in a moving vehicle. Your Scooter is not designed to be used as such and cannot protect you in the event of an automobile accident or an abrupt stop.

WARNING! Always protect batteries from freezing temperatures and never charge a frozen battery. This damages the battery and may cause personal injury. Attempting to charge a battery in freezing conditions does not prevent a battery from freezing.

WARNING! Battery posts, terminals and related accessories contain lead and lead compounds. Wash hands after handling.

II. SAFETY



CAUTION! Do not expose the electronics to any type of moisture at any time (rain, snow, mist, or wash). Such exposure can damage the electronics. Never attempt to ride a Scooter that has been exposed to moisture until it has dried thoroughly.

CAUTION! Secure the batteries before loading your Scooter into another vehicle for transport.

CAUTION! Disconnect the batteries if you are not going to operate your Scooter for more than 48 hours.

As you begin to use your Victory XL-8 during your daily activities, you will encounter situations that may require some practice. Simply take your time as you operate your Scooter and you will soon be in full and confident control as you maneuver through doorways, on and off of elevators, up and down ramps, and over moderate terrain.

DOORS

- Determine if the door opens toward or away from you.
- Use your hand to turn the knob or push the handle or push-bar.
- Drive your Victory XL-8 slowly forward to push the door open; or drive your Scooter slowly backwards to pull the door open.

ELEVATORS

Modern elevators have a door-edge safety mechanism that, when pushed, reopens the elevator door(s).

- If you are in the doorway of an elevator when the door(s) begin to close, push on the rubber door edge or allow the rubber door edge to contact the Scooter to reopen the door.
- Use care that pocketbooks, packages, or Victory XL-8 accessories do not become caught in the elevator doors.

RAMPS AND OTHER INCLINES

More and more buildings have ramps with specified degrees of inclination, designed for easy and safe Scooter access. Some ramps may have turning switchbacks that require you to have good cornering skills on your Victory XL-8.

- Take wide swings with your Scooter's front wheels around any tight corners. If you do that, the rear wheels will follow a wide arc and will not cut the corner short, bump into, or get hung up on any railing corners.
- When driving down a ramp, keep your Victory XL-8's speed adjustment dial (see IV. "Description") set to the tortoise (slowest speed setting) to ensure a safely controlled descent.
- Avoid sudden stops and starts.

II. SAFETY

Other inclines may be natural or, if man-made, not designed specifically for Scooters. Figure 1 illustrates your Scooter's stability and its ability to climb grades under various weight loads and under controlled testing conditions.

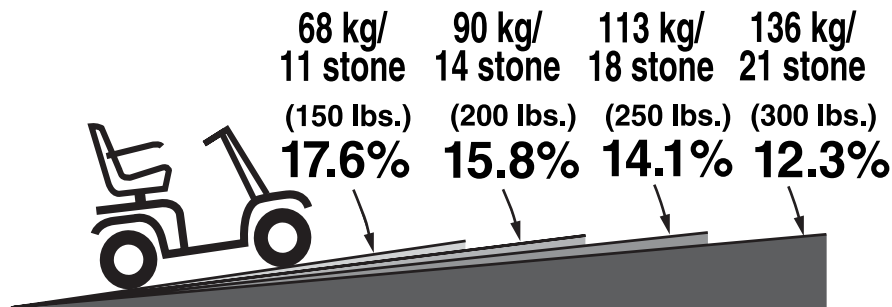

Figure 1. Maximum Recommended Incline Angle

Controlled incline testing was conducted with the Scooter's seat in the highest position, adjusted backward on the seat base to the farthest rearward position. These tests show that your Scooter's ability to travel up inclines is affected by your weight, your Scooter's speed, your angle of approach to the incline, and your Scooter setup.

When you approach an incline, it is best to lean forward. See figures 2 and 3. This shifts the center of gravity of you and your Victory XL-8 toward the front of the Scooter for improved stability.



WARNING! Do not exceed the incline guidelines or any other specifications presented in this manual.



Figure 2. Normal Driving Position

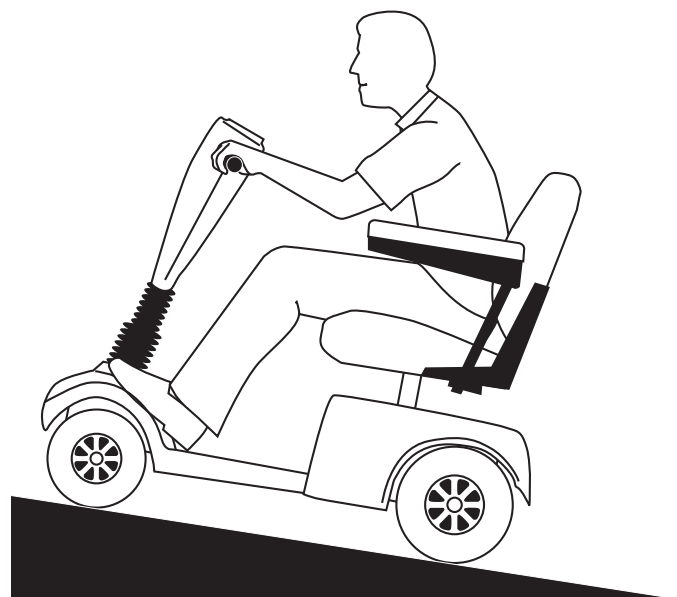

Figure 3. Increased Stability Driving Position

II. SAFETY

DRIVING SURFACES

Your Victory XL-8 was designed to provide optimum stability under normal driving conditions — dry, level surfaces composed of concrete or asphalt. However, Pride recognizes that there will be times when you will operate your Scooter on surfaces other than concrete or asphalt. For that reason, we also designed your Victory XL-8 to perform admirably on packed soil, grass, and gravel.

- Feel free to use your Victory XL-8 safely on lawns and in park areas.
- Avoid tall grass that can entangle the running gear.
- Packed soil, gravel, driveways, or roads will not present a problem for your Victory XL-8.
- Avoid loosely packed gravel and sand.
- If you feel unsure about a driving surface, avoid that surface.

III. SPECIFICATIONS

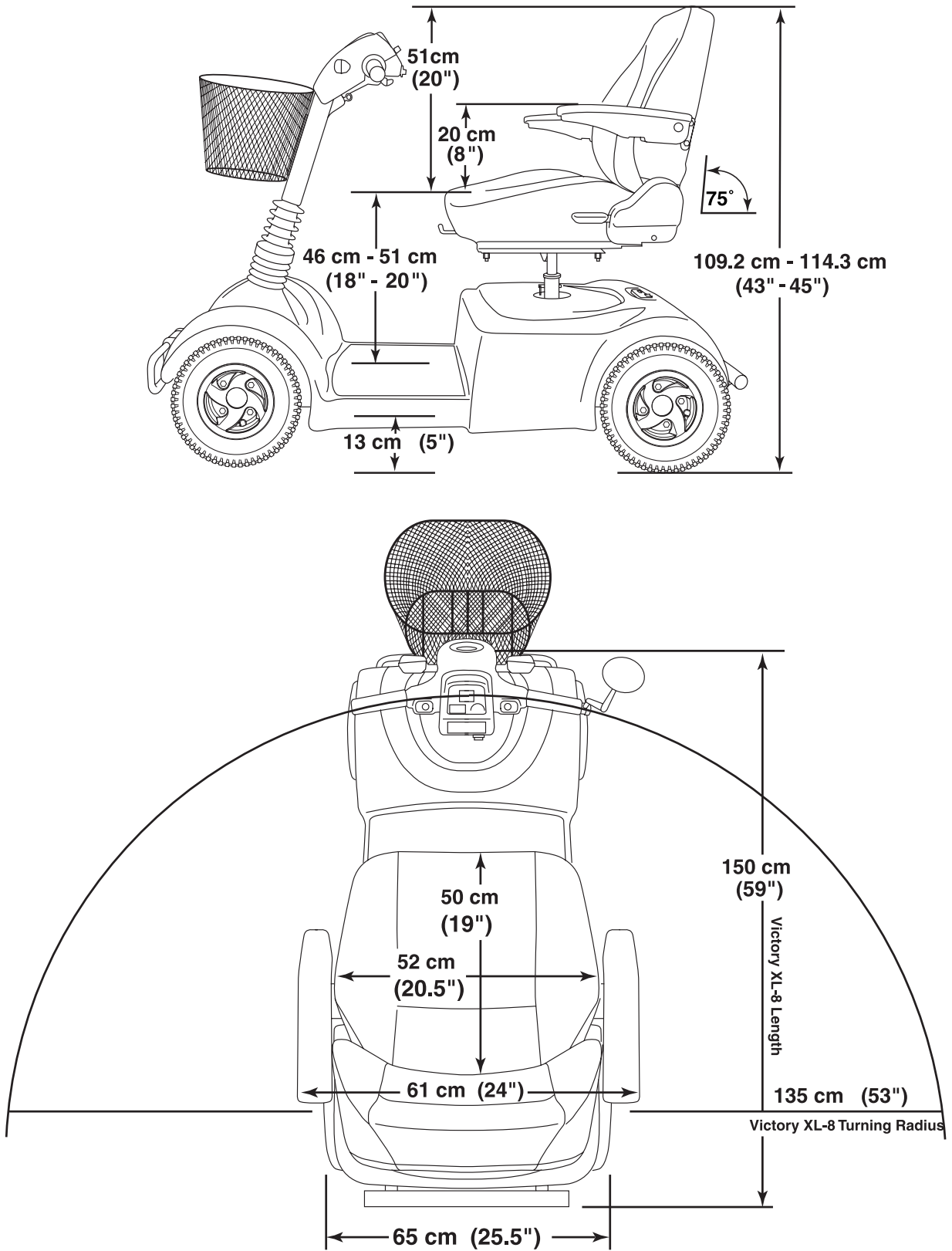

FIGURE 4. VICTORY XL-8 SPECIFICATIONS

III. SPECIFICATIONS

Specifications	
Length:	150 cm (59")
Width:	65 cm (25.5")
Tyres:	Type: Pneumatic; 10 cm x 33 cm (4" x 13")
Weight Capacity:	136 kg/21 stone (300 lbs.) maximum
Battery Type (not included):	Choices: Two 12 V 32 amp hours (AH), U-1 type, Sealed Lead Acid (SLA); two 12 V 40 AH, U-1 type, SLA; two 12 V 45 AH NF-22, SLA; or two 12 V 55 AH NF-22, SLA
Horsepower:	2.0 HP (Peak)
Charger:	Onboard 5 amp charger
Speed (Max):	Variable up to 13 km/hr (8 mph)
Maximum Grade:	Please refer to figure 1.
Range (per charge):	12 V 32 AH: up to 32 - 40 km (20 - 25 miles); 12 V 40 AH: up to 40 - 48 km (25 - 30 miles); 12 V 45 AH NF-22: up to 48 - 56 km (30 - 35 miles); 12 V 55 AH NF-22: up to 56 - 64 km (35 - 40 miles)
Turning Radius:	135 cm (53")
Body Colours:	Candy Apple Red, Green, or Viper Blue
Seating:	Style: High back with reclining mechanism and user-adjustable sliding seat mechanism Dimensions: 52 cm (20.5") width (usable) x 51 cm (20") height (usable) x 50 cm (19") depth (usable) Seat Cover Material: Gray vinyl Armrests: Black molded rubber User adjustable seat height from ground: 62 - 67 cm (24.5" - 26.5") User adjustable seat height from Scooter deck: 46 - 51 cm (18" - 20")
Included Features:	Full dynamic front/rear suspension; triple-sized battery compartment (for U-1, 40 AH, or NF-22); standard front and rear bumpers; full light package; high-back seat with user adjustable recline angle, armrests, and sliding mechanism; external manual freewheel release lever; external circuit breaker; easily accessible battery charge A/C plug receptacle; recessed tiller headlight; front basket; onboard accessory bracket; microprocessor based motor controller; energy saving auto shutoff feature
Brakes:	Electronic regenerative braking and electromechanical disc brake
Rear Wheel Drive:	Transaxle, 24 V
Wheels:	Aluminum alloy wheels; color matches shroud
Tiller Type:	Adjustable
Freewheel Mechanism:	Manual freewheel release lever located upon upper-right rear portion of rear shroud
Scooter Weight:	Total weight with batteries: 12 V 32 AH: 103 kg (226 lbs.); 12 V 40 AH: 109 kg (241 lbs.); 12 V 45 AH: 114 kg (252 lbs.); 12 V 55 AH: 117 kg (258 lbs.) Total weight without batteries: 80 kg (176 lbs.) Component Breakdown: Front Section (w/out basket): 26 kg (57 lbs.) Rear Section (w/out batteries or rear shroud): 30 kg (66 lbs.) Rear Plastic Shroud: 2 kg (5 lbs.) Seat: 21 kg (46.5 lbs.) Basket: .7 kg (1.5 lbs.) Batteries: 12 V 32 AH: 11 kg (25 lbs.) each; 12 V 40 AH: 15 kg (32.5 lbs.) each; 12 V 45 AH: 17 kg (38 lbs.) each; 12 V 55 AH: 19 kg (41 lbs.) each
Front-to-rear Lockup:	Lock pin and dual camlock lever system
Ground Clearance:	13 cm (5")
Optional Accessories:	Rear basket; safety flag; single crutch holder; walker holder; oxygen bottle holder

IV. DESCRIPTION

Your Victory XL-8 is a motorized electric Scooter designed to enhance your personal mobility. It is an indoor/outdoor Scooter that was designed to travel primarily on smooth surfaces such as sidewalks, roads, parking lots, floors, and driveways. For easy transportation or storage, you can disassemble your Victory XL-8 into seven components. See figure 5.



Figure 5. Victory XL-8 Components

CONTROL CONSOLE ASSEMBLY

The control console assembly located on the front section houses all of the controls you need to operate your Victory XL-8. See figure 6.



CAUTION! Do not expose the control console assembly to moisture. In the event it does become exposed to moisture, do not attempt to operate your Victory XL-8 until it has dried thoroughly.

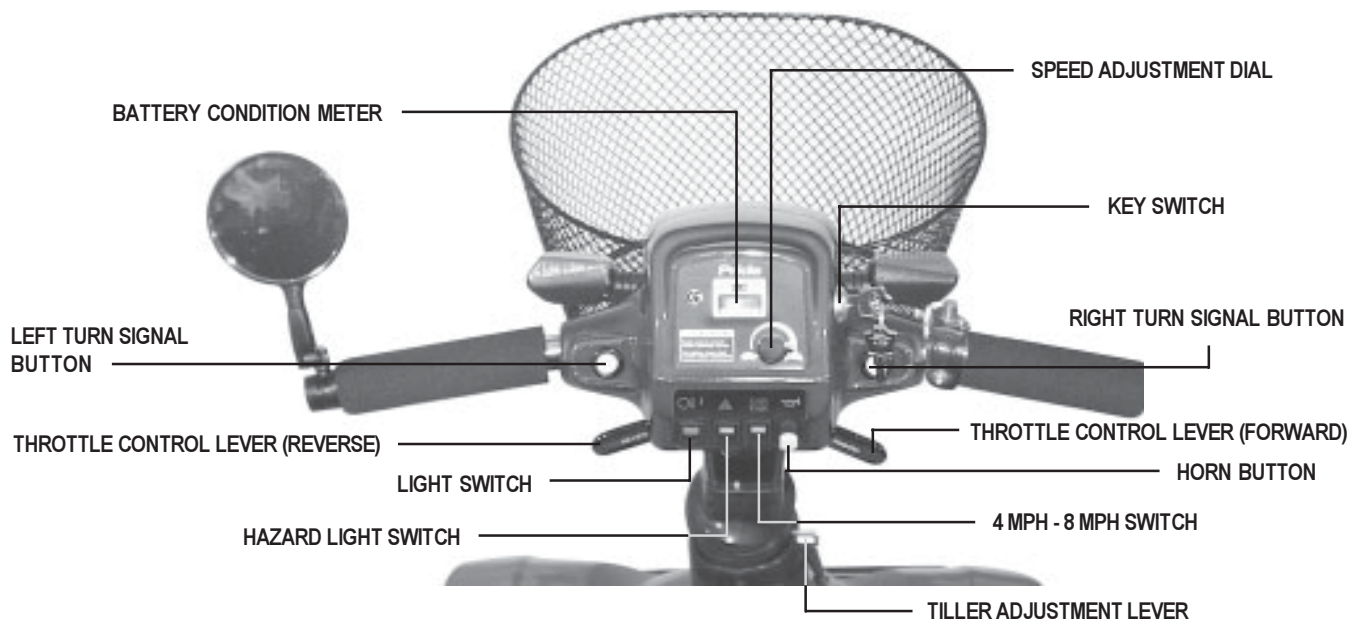

Figure 6. Control Console Assembly

IV. DESCRIPTION

Speed Adjustment Dial

This dial allows you to preselect and limit your Victory XL-8's top speed up to the highest speed you set with the 4 MPH - 8 MPH switch (either 6.4 km/hr or 12.8 km/hr).

- Set the speed between the slowest (image of the tortoise) and the fastest (image of the hare) speed settings.

Left and Right Turn Signal Buttons

Use these buttons to turn on the left and right turn signal lights.

- Push the appropriate turn signal button once to illuminate the signal light before turning your Victory XL-8. Your Scooter's turn signals are timed to shut off automatically.

Handbrake Lever (Not shown)

Your Scooter is equipped with a handbrake lever, located on the tiller handle. This lever provides you with additional stopping power.

- Release the throttle and gently squeeze the handbrake lever to come to a stop.

NOTE: If you do not release the throttle before using the handbrake lever, your Scooter may not come to a complete stop.

Horn Button

This button activates a warning horn.

- Ensure the key is fully inserted into the key switch and push the horn button to sound the horn.

Throttle Control Levers

These levers allow you to control the forward and the reverse speed up to the maximum speed you preset on the 4 MPH - 8 MPH switch and the speed adjustment dial. For instructions on how to operate your Victory XL-8's throttle control, see VI. "Operation."

4 MPH - 8 MPH Switch

This switch limits your Victory XL-8's top speed to either 6.4 or 12.8 km/hr (4 or 8 mph).

- Toggle this switch to either 4 MPH or 8 MPH.

NOTE: When driving indoors, set the switch to 4 MPH.

Key Switch

This switch enables you to power up and power down your Victory XL-8 Scooter.

- Fully insert the key into the key switch and turn the key clockwise to power up your Victory XL-8.
- Pull the key out to power down your Victory XL-8.



WARNING! If the key is removed from the key switch while your Victory XL-8 is in motion, the electronic brakes will engage and your Victory XL-8 will come to an abrupt stop!

IV. DESCRIPTION

Hazard Light Switch

This switch enables you to control your Victory XL-8's front and rear (amber) hazard lights.

- Toggle this switch to turn the hazard lights on and off.

Light Switch

This switch enables you to control your Victory XL-8's headlight and running (rear red) lights.

- Press this switch once to turn on the lights.
- Press it again to turn off the lights.

Battery Condition Meter

When your Victory XL-8's key is fully inserted and turned clockwise to power on your Scooter, this meter indicates the approximate battery voltage strength. For further information on battery charging, see V. "Batteries and Charging."

REAR SECTION

The batteries, onboard battery charger, battery charger fuse, manual freewheel lever, main circuit breaker, motor/transaxle assembly, charger power cord receptacle, and electronic controller module are located on the rear section of your Victory XL-8. The anti-tip wheels are at the rearmost part of your Victory XL-8. See figure 7. Refer to VIII. "Disassembly and Assembly" for instructions on removing the rear shroud.

Batteries

The batteries store the electrical energy that powers your Victory XL-8. For directions on charging your batteries, see V. "Batteries and Charging."

Onboard Battery Charger

The onboard battery charger converts household current (AC) to direct current (DC) and charges your Victory XL-8's batteries. See V. "Batteries and Charging."

- The charger is located behind the batteries and at the forward right corner of the rear section.
- The charger is a gold-colored box with cooling fins on the exterior of its case.
- The charger power cord plugs into your Victory XL-8's battery charger by means of a receptacle located on the rear section of your Victory XL-8, near the manual freewheel lever and the main circuit breaker reset button.

Battery Charger Fuse

The fuse has been incorporated into your charger to protect it from damage if there is an electrical problem.

- It is located under a cap on the outside of the battery charger.
- The cap unscrews to allow access to the fuse.
- Unscrew the cap and replace the fuse if it has blown.



CAUTION! The replacement fuse must match exactly the rating of the original fuse. If you install a fuse with an incorrect rating, you may damage the charger. Contact your local Pride provider for fuse rating information.

IV. DESCRIPTION

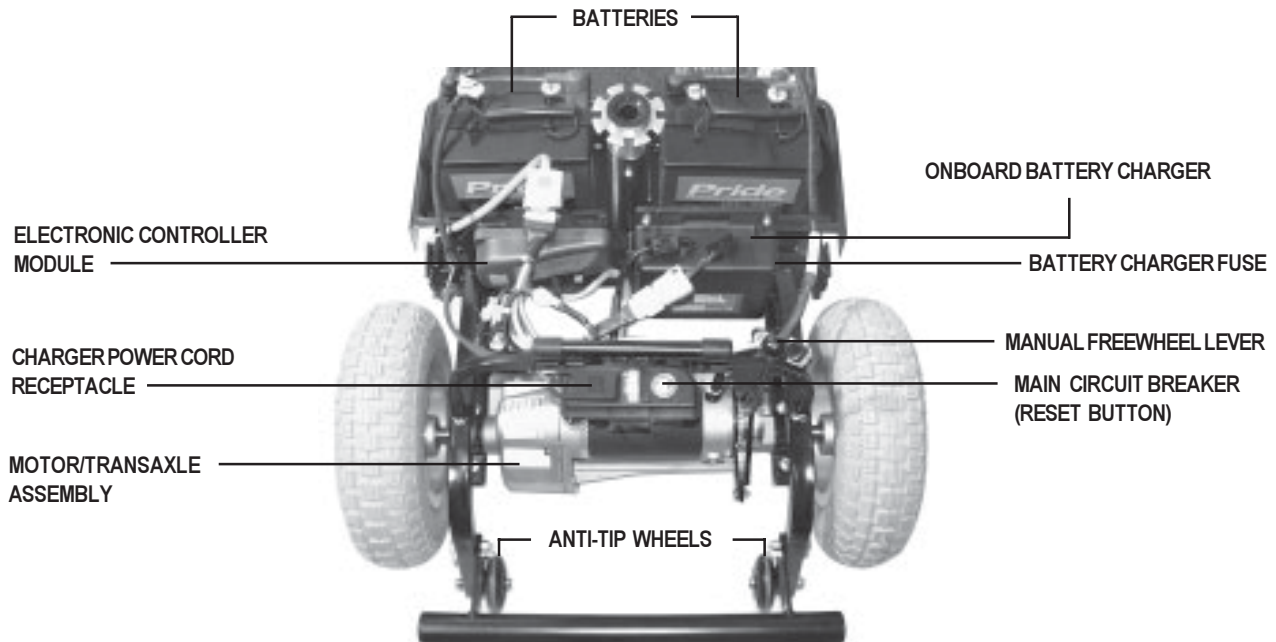

Figure 7. Rear Section

Manual Freewheel Lever

Whenever you want to push your Victory XL-8 for short distances, you can put it in manual freewheel mode.

It is important to remember that when your Victory XL-8 is in manual freewheel mode, the braking system is disengaged. Even though the motor of your Victory XL-8 is disengaged from the drive system when your Scooter is put in manual freewheel mode, the motor can still run if the throttle lever is pushed.

WARNING! Follow these safety rules when using the manual freewheel mode:



- **Do not disengage the drive motors when your Victory XL-8 is on an incline; the Scooter could roll down on its own and cause injury.**
- **Before placing your Victory XL-8 in or taking it out of manual freewheel mode, ensure the key is removed from the key switch.**
- **Never sit on a Scooter when it is in manual freewheel mode.**
- **When you have finished pushing your Scooter, always return it to the drive mode to lock the brakes.**

- The manual freewheel lever is located on the end of the motor/transaxle assembly at the right rear of the Scooter.
- Pull up the manual freewheel lever to disable the drive system and the brake system; you will then be able to push your Victory XL-8.
- Push down on the manual freewheel lever to reengage the drive system and the brake system and take your Victory XL-8 out of manual freewheel mode.

IV. DESCRIPTION

Main Circuit Breaker

When the voltage in your Victory XL-8's batteries becomes low or your Scooter is heavily strained because of excessive loads, the main circuit breaker may trip to protect your Victory XL-8's motor and electronics from damage.

When your Victory XL-8's main circuit breaker trips, the reset button pops out and your Victory XL-8 shuts down. (The main circuit breaker reset button is mounted on the upper rear section of your Victory XL-8, near the charger power cord receptacle.) If the reset button pops out, perform the following steps.

1. Allow a minute or so for your Victory XL-8's electronics to "rest."
2. Push in the reset button to reset the breaker.

Motor/Transaxle Assembly

The motor/transaxle assembly consists of a geared transmission and differential. This one piece, direct drive, fully sealed assembly provides quiet operation with maximum power and long life.

Charger Power Cord Receptacle

This receptacle enables you to plug the charger power cord into the Victory XL-8. For further details on using the charger power cord, refer to V. "Batteries and Charging."

Electronic Controller Module

This module is located behind the batteries and at the forward left corner of your Victory XL-8's rear section. The controller module receives electrical signals from the console controls and sends power to the motor, the brakes, and the lighting system.



WARNING! Do not expose the electronic controller module to moisture. If it does become exposed to moisture, do not attempt to operate your Victory XL-8 until it has thoroughly dried.

Anti-tip Wheels

The anti-tip wheels are an integral and important safety feature of your Victory XL-8 which prevent your Scooter from tipping backwards on an incline. They are located at the rearmost part of your Scooter.



WARNING! Do not remove your Scooter's anti-tip wheels or modify your Scooter in any way that is not authorized by Pride Mobility Products, Ltd.

IV. DESCRIPTION

OPTIONAL ACCESSORIES

For information concerning these optional accessories, contact your authorized Pride provider.



• SINGLE CRUTCH HOLDER



• SAFETY FLAG



• WALKER HOLDER



• OXYGEN BOTTLE HOLDER



• REAR BASKET

V. BATTERIES AND CHARGING

Your Victory XL-8 requires two long-lasting, 12-volt, deep-cycle batteries that are sealed and maintenance free. You can recharge the batteries with the convenient onboard 5-amp charging system.

- Charge your Victory XL-8's batteries with the supplied onboard battery charger prior to using it for the first time.
- Keep your batteries fully charged to keep your Victory XL-8 running smoothly.

NOTE: Use only the onboard battery charger supplied with your Victory XL-8.

CHARGING YOUR BATTERIES

The battery condition meter on the control console assembly indicates the approximate strength of your batteries. To check the charge, you must ensure the key is inserted in the key switch.

Follow these steps to safely charge your batteries.

1. Position your Scooter close to a standard wall outlet.
2. Turn the key counterclockwise to power off your Scooter.
3. Ensure the manual freewheel lever is in the down (drive) position.
4. Plug the charger power cord into the charger power cord receptacle at the rear of your Victory XL-8.
5. Extend the charger power cord and plug it into the wall outlet. We recommend you charge your Victory XL-8's batteries for 8 to 14 hours.



WARNING! Never use an extension lead to plug in your battery charger. Plug the charger directly into a properly wired standard wall outlet.

6. You can periodically check the battery condition meter by inserting the key in the key switch, examining the battery condition meter, and then removing the key. As the batteries charge, the battery condition meter approaches the 100% reading.
7. When the batteries are fully charged, unplug the charger power cord from the wall outlet and then from the charger power cord receptacle at the rear of your Victory XL-8.
8. Place the charger power cord in a safe place for future use.

FREQUENTLY ASKED QUESTIONS (FAQs)

How does the charger work?

When your Victory XL-8's battery voltage is low, the charger works harder and sends more electrical current to the batteries to bring up their charge. As the voltage of the batteries approaches a full charge, the charger sends less electrical current to the batteries. When the batteries are fully charged, the current sent to them from the charger is at nearly zero amperage. Therefore, when the charger is plugged in, it maintains the charge on your Victory XL-8's batteries but does not overcharge them. We do not recommend that you charge your Victory XL-8's batteries for more than 24 consecutive hours.

What do the LEDs on the charger indicate?

The onboard battery charger is equipped with two Light Emitting Diodes (LEDs) that indicate the charging status of your Scooter's batteries. The red LED lights up to indicate the battery charging is in progress. The green LED flashes when your Scooter's batteries reach full charge.

Can I use a different charger?

For the safest, most efficient, and balanced charging of your Victory XL-8's batteries, you should simultaneously charge both batteries using only the manufacturer-supplied onboard battery charger.

V. BATTERIES AND CHARGING

How often must I charge the batteries?

Two major factors must be considered when deciding how often to charge your Victory XL-8's batteries: all day Scooter use on a daily basis and infrequent Scooter use.

With these considerations in mind, you can determine just how often and for how long you should charge your Victory XL-8's batteries. We designed the onboard charger so that it does not overcharge your Scooter's batteries; however, you may encounter some problems if you do not charge your batteries often enough and if you do not charge them on a regular basis. Following the five guidelines below provides safe and reliable battery operation and charging.

1. If you use your Victory XL-8 daily, charge its batteries as soon as you finish using it for the day. Your Scooter will be ready each morning to give you a "full day" of service. We recommend you charge your Victory XL-8's batteries for 8 to 14 hours after daily use.
2. If you use your Victory XL-8 once a week or less, charge its batteries at least once a week for 12 to 14 hours at a time.
3. Keep your Victory XL-8's batteries fully charged.
4. Avoid deeply discharging your Victory XL-8's batteries.
5. Do not charge your Victory XL-8's batteries for more than 24 consecutive hours.

How can I get maximum range or distance per charge?

Rarely will you have ideal driving conditions — smooth, flat, hard driving surfaces with no wind or curves. You will often face hills, sidewalk cracks, uneven and loosely packed surfaces, curves, and wind. All of these driving conditions affect the distance or running time per battery charge. The following are a few suggestions for obtaining the maximum range per battery charge.

- Always fully charge your Victory XL-8's batteries prior to your daily use.
- Maintain 30 psi (pounds per square inch) in all of your Victory XL-8's tyres.
- Plan your route ahead to avoid as many hills, cracked, broken, or soft surfaces as possible.
- Limit your baggage weight to essential items.
- Try to maintain an even speed while your Victory XL-8 is in motion.
- Avoid stop-and-go driving.

What type and size of battery should I use?

We recommend deep-cycle batteries that are sealed and maintenance free. Both Sealed Lead Acid (SLA) and Gel-Cell are deep-cycle batteries that are similar in performance in your Victory XL-8. Do not use wet-cell batteries, which have removable caps.

NOTE: Do not remove the caps from sealed batteries. Water cannot be added to sealed batteries. Cap removal voids the battery warranty and may cause damage to the batteries and to your Victory XL-8.

Use these specifications to reorder deep-cycle batteries.

Type:	Deep-cycle (SLA or Gel-Cell)
Size:	U-1 (32 AH, 40 AH) or NF-22 (45 AH, 55 AH)
Voltage:	12 V each
Amperage:	32 AH, 40 AH, 45 AH, or 55 AH

V. BATTERIES AND CHARGING

To change a battery in your Victory XL-8:

1. Remove the seat and the rear shroud. See VIII. “Disassembly and Assembly.”
2. Remove the battery tie-down strap.
3. Disconnect the battery cables from the electronic controller module.
4. Disconnect the battery cables from the battery terminals.
5. Remove the old battery.
6. Place a new battery in the battery well.
7. Connect the red battery cable to the positive (+) battery terminal.
8. Connect the black battery cable to the negative (-) battery terminal.
9. Reconnect the battery cables to the electronic controller module.
10. Fasten the battery tie-down strap.
11. Reinstall the rear shroud and the seat.



WARNING! Battery posts, terminals and related accessories contain lead and lead compounds. Wash hands after handling.

Why do my new batteries seem weak?

Deep-cycle batteries employ a different chemical technology than that used in car batteries, nickel-cadmium batteries (nicads), or in other common battery types. Deep-cycle batteries are specifically designed to provide power, drain down their charge, and then accept a relatively quick recharge.

We work closely with our battery manufacturer to provide batteries that best suit your Victory XL-8’s specific electrical demands. Fresh batteries arrive daily at Pride and are shipped fully charged to our customers. During shipping, the batteries may encounter temperature extremes that may influence their initial performance. Heat diminishes the charge on the battery; cold slows the available power and extends the time needed to recharge the battery.

It may take a few days for the temperature of your Victory XL-8’s batteries to stabilize and adjust to their new room or ambient temperature.

More importantly, it takes a few charging cycles (a partial drain followed by a full recharge) to establish the critical chemical balance that is essential to a deep-cycle battery’s peak performance and long life.

Please follow these steps to properly break in your Victory XL-8’s new batteries for maximum efficiency and service life.

1. Fully charge any new battery prior to its initial use. This initial charging cycle brings the batteries up to about 88% of their peak performance level.
2. Operate your new Victory XL-8 in familiar and safe areas. Drive slowly at first, and do not travel too far from your home or familiar surroundings until you have become accustomed to your Victory XL-8’s controls and have properly broken in your Scooter’s batteries.
3. Fully recharge the batteries. This recharge should bring the batteries up to about 90% of their peak performance level.
4. Operate your Victory XL-8 again.

V. BATTERIES AND CHARGING

5. Fully recharge the batteries again.
6. After four or five charging cycles, the batteries are able to receive a charge of 100% of their peak performance level and are able to last for an extended period of time.

How can I ensure maximum battery life?

Fully charged deep-cycle batteries provide reliable performance and extended battery service life. Keep your Victory XL-8's batteries fully charged whenever possible. Batteries that are deeply discharged, infrequently charged, or stored without a full charge may be permanently damaged and cause unreliable performance and limited service life.

How should I store my Victory XL-8 and its batteries?

If you plan on not using your Victory XL-8 for an extended period of time, it is best to:

- Fully charge its batteries prior to storage.
- Disconnect the battery harnesses from the electronic controller module.
- Store your Victory XL-8 in a warm, dry environment.
- Avoid storing your Victory XL-8 where it will be exposed to temperature extremes.



WARNING! If your Victory XL-8's batteries do become frozen, do not attempt to charge them. Cold or frozen batteries should be allowed to warm up for several days prior to recharging.

For prolonged storage, you may wish to place several boards under the frame of your Victory XL-8 to raise the Scooter off the ground and take the weight off the tyres. This reduces the possibility of flat spots developing on the areas of the tyres contacting the ground.

VI. OPERATION

PRE-RIDE ADJUSTMENTS AND CHECKS

Familiarize yourself with the following checklist before you get on your Victory XL-8. Some of the checks must be performed prior to getting on your Scooter.

- Have you fully charged the batteries? See V. “Batteries and Charging.”
- Is the manual freewheel lever in the down (drive) position? See IV. “Description.” Never leave the manual freewheel lever pulled up unless you are manually pushing your Victory XL-8.
- Is your proposed path clear of people, pets, and obstacles?
- Have you planned your route to avoid adverse terrain and as many inclines as possible?
- Are you positioned comfortably in the seat? See “Getting On Your Victory XL-8,” below.
- Is the seat at the proper height? See VII. “Comfort Adjustments.”
- Is the seat locked securely in place? See VII. “Comfort Adjustments.”
- Is the tiller handle at a comfortable setting and locked securely in place? See VII. “Comfort Adjustments.”
- Is the key fully inserted into the key switch? See IV. “Description.”
- Is the speed adjustment dial set to a slow setting? See IV. “Description.”
- Are you grasping the handgrips with a thumb resting on each throttle lever? See IV. “Description.”
- Does your Victory XL-8’s horn work properly?

GETTING ON YOUR VICTORY XL-8

1. Make certain that the key is turned counterclockwise to power down your Scooter.
2. Stand at the side of your Victory XL-8.
3. Push down on the seat lock lever and rotate the seat until it faces you.
4. Make certain that the seat is locked securely in position.
5. Position yourself comfortably and securely in the seat.
6. Push down on the seat lock lever and rotate the seat until you face forward.
7. Make certain that the seat is locked securely in position.
8. Make certain that your feet are safely on the floorboard.

OPERATING YOUR VICTORY XL-8

After planning your route:

1. Set the 4 MPH - 8 MPH switch to your desired maximum speed of 6.4 or 12.8 km/hr (4 or 8 mph); then set the speed adjustment dial to your desired speed.

NOTE: Initially you should set the 4 MPH - 8 MPH switch to 4 MPH and the speed adjustment dial to the slowest setting. Once you become comfortable with your Scooter, you can increase your speed.

2. Insert the key into the key switch and turn the key clockwise to power up your Scooter.
3. With your hands on the handgrips, use your thumb to gently push the right throttle lever to disengage your Victory XL-8’s brakes and move forward; the electric brake automatically disengages and the Victory XL-8 accelerates smoothly to the speed you set with the speed adjustment dial.
4. Pull on the left handgrip to steer your Victory XL-8 to the left.
5. Pull on the right handgrip to steer your Victory XL-8 to the right.
6. Move the tiller to the center position to drive straight ahead.
7. Gently release the throttle lever to decelerate and come to a complete stop. The electric brake automatically engages when your Victory XL-8 comes to a stop.

V I . O P E R A T I O N

NOTE: To stop your Scooter, if it is equipped with a handbrake lever, release the throttle, then gently squeeze the handbrake lever.

8. To move in reverse, use your thumb to gently push the left throttle lever to disengage your Victory XL-8's brakes and move rearward.

NOTE: Your Scooter's reverse speed is 40% slower than the speed you set with the speed adjustment dial and the 4 MPH - 8 MPH switch.

GETTING OFF OF YOUR VICTORY XL-8

1. Bring your Victory XL-8 to a complete stop.
2. Make certain that the key is turned counterclockwise to power down your Scooter.
3. Push down on the seat lock lever and rotate the seat until you are facing toward the side of your Victory XL-8.
4. Make certain that the seat is locked securely in position.
5. Carefully get out of the seat and stand at the side of your Victory XL-8.
6. You may, if you wish, leave the seat facing to the side to facilitate boarding your Victory XL-8 the next time you are going to operate it.

AUTO SHUTOFF FEATURE

Your Victory XL-8 is equipped with an energy saving auto shutoff feature designed to preserve your Scooter's battery life. If you mistakenly leave the key in your Victory XL-8 but do not use the Scooter for approximately 20 minutes, the Scooter automatically shuts down.

If your Victory XL-8 auto shutoff feature takes effect, perform the following steps to resume normal operation.

1. Turn the key counterclockwise to power down your Scooter.
2. Turn the key clockwise to power up your Scooter.

VII. COMFORT ADJUSTMENTS



WARNING! Remove the key from the key switch before adjusting the tiller or the seat. Never attempt to adjust the tiller or the seat while the scooter is in motion.

TILLER ANGLE ADJUSTMENT

You can adjust the tiller to many positions. The tiller adjustment lever locks the tiller in place; it has a spring-loaded mechanism that enables you to rotate it and change its position.

1. Turn the tiller adjustment lever counterclockwise until it is loose. If the tiller adjustment lever comes in contact with the tiller basket, pull it outward, turn it clockwise, and release it. Continue to loosen until you are able to move the tiller. See figure 8.
2. Squeeze the release buttons (located beneath the tiller boot) and move the tiller to a comfortable position.
3. Turn the tiller adjustment lever clockwise until it is tight. If the tiller adjustment lever comes in contact with the tiller basket, pull it outward, turn it counterclockwise, and release it. Continue to turn the lever until it is tight. The tiller may be lowered to the center of the floorboard and locked in place for storage. See VIII. “Disassembly and Assembly.”

SEAT HEIGHT ADJUSTMENT

The seat can be repositioned to one of three different heights.

1. Remove the seat from your Victory XL-8. See VIII. “Disassembly and Assembly.”
2. Use the attached ring to pull and remove the ball detent pin from the seat pedestal. See figure 9.
3. Raise or lower the seat post tower to the desired seat height.
4. Hold the seat post tower at that height and match up the holes in the seat post tower with the seat pedestal.
5. Fully insert the ball detent pin.
6. Replace the seat.

NOTE: The supplied nut, bolt, and washers can be used as an alternate to the ball detent pin for seat height adjustment and stability.

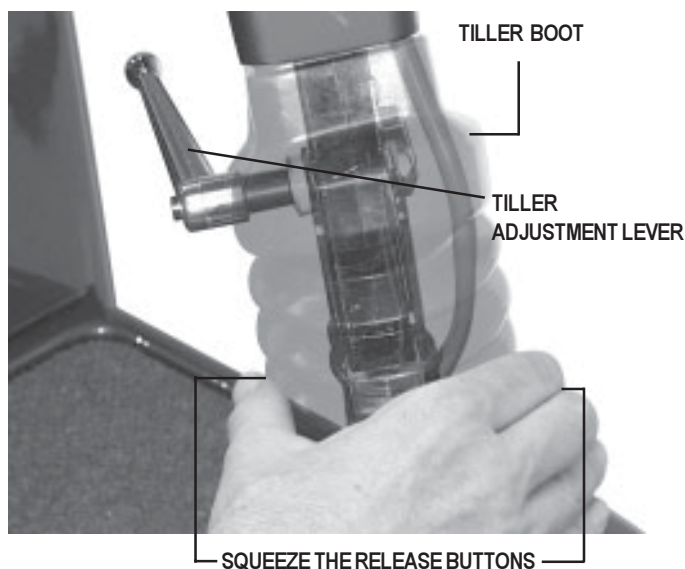

Figure 8. Tiller Angle Adjustment

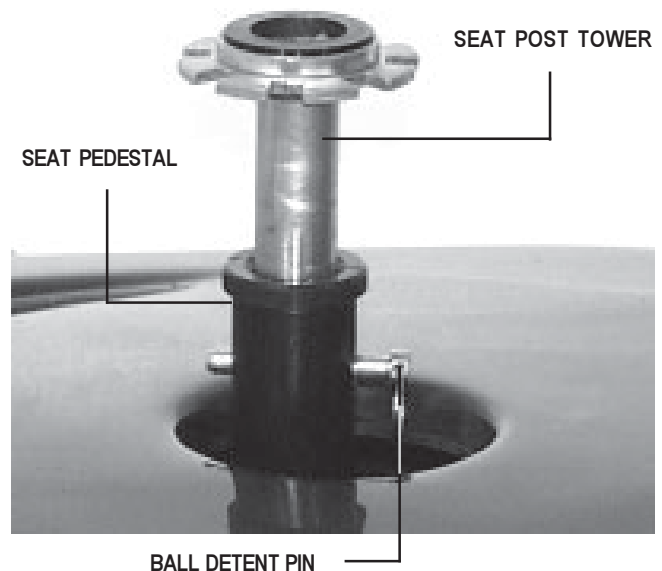

Figure 9. Seat Height Adjustment

VII. COMFORT ADJUSTMENTS

SLIDING SEAT ADJUSTMENT

You can reposition the Victory XL-8's seat forward or rearward to one of three settings to adjust the distance between the seat and the tiller.

1. Pull up on the seat sliding lever. See figure 10.
2. Hold the lever up and slide the seat forward or rearward into a comfortable position.
3. Release the seat sliding lever to lock the seat securely in place.

SEAT ROTATION

The seat lock lever locks the seat in one of eight positions.

1. Push down on the seat lock lever to unlock the seat. See figure 10.
2. Rotate the seat to the desired position.
3. Release the seat lock lever to lock the seat securely in place. If the seat is not locked into position, gently rock the seat back and forth until you hear the lever click.

SEATBACK ADJUSTMENT

You can adjust the recline angle of your Scooter's seat.



WARNING! Always keep your back pressed firmly against the seatback while adjusting the angle.

1. Pull up on the seat recline lever to unlock the seatback. See figure 11.
2. Lean forward or backward to adjust the seatback to a comfortable position.
3. Release the seat recline lever to lock the seat securely in place.

ARMREST ANGLE ADJUSTMENT

You can adjust the armrest angle of your Victory XL-8.

1. While seated in your Victory XL-8, turn the armrest adjustment dial to the left to lower the armrest angle or to the right to raise the armrest angle. See figure 12.

NOTE: The armrests also pivot upward to make getting on and off of your Victory XL-8 easier.



Figure 10. Seat Adjustment

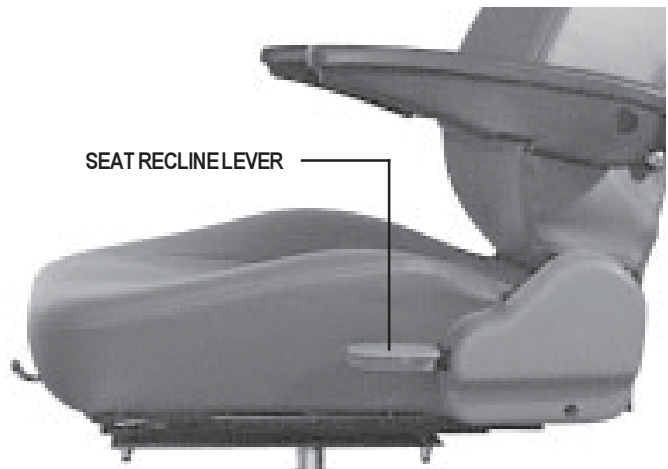

Figure 11. Seatback Adjustment



Figure 12. Armrest Angle Adjustment

VIII. DISASSEMBLY AND ASSEMBLY

No tools are required to disassemble or assemble your Victory XL-8 Scooter. Always disassemble or assemble your Victory XL-8 on a level, dry surface, with sufficient room for you to work and move around your Scooter. Keep in mind that the disassembled sections of the Victory XL-8 take up more floor space than the assembled Victory XL-8.

DISASSEMBLY

You can disassemble the Victory XL-8 into seven components: the seat, the front section, the front basket, the rear section, the rear shroud, and the two batteries. Place the Scooter in an area where you have sufficient clearance to move the parts around. You need about 1.5 meters in all directions. You may need assistance to lift some of the Scooter components. See III. “Specifications” for individual component weights.

1. Remove the key from the key switch.
2. Pull up on the manual freewheel lever to make it easier for you to maneuver the rear section.
3. Ensure the seat is locked into position; then lift the seat up and off of your Victory XL-8.
4. Gently lift the rear shroud off of your Victory XL-8. The rear shroud is held in place with reusable fasteners.
5. Unplug both battery harnesses. See figure 13.
6. Disconnect the battery tie-down strap, then lift both batteries from the battery wells.
7. Unplug the large, white, 9-pin front-to-rear connector that attaches the front control console harness to the electronic controller module harness.



CAUTION! Failing to unplug both battery harnesses and the front-to-rear connector prior to further disassembly could result in permanent damage to your Victory XL-8.

8. Turn the tiller adjustment lever counterclockwise until it is loose. Pull the rubber boot upward to expose the tiller release buttons. Place one hand on the rear of the tiller and carefully depress both tiller release buttons while slowly lowering the tiller to the center of the floorboard.
9. Remove the ball detent pin from the frame. See figure 14.
10. Move the camlock levers to the unlocked, vertical position.
11. Place one hand on the seat post tower and one hand on the front frame handle; gently slide the front and rear sections apart. See figure 15.

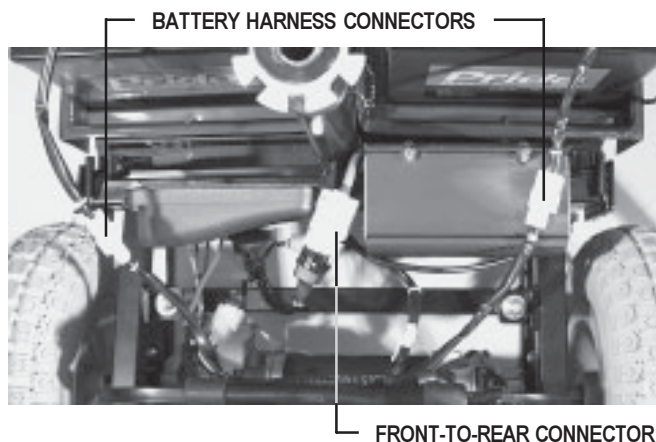

Figure 13. Cable Connections

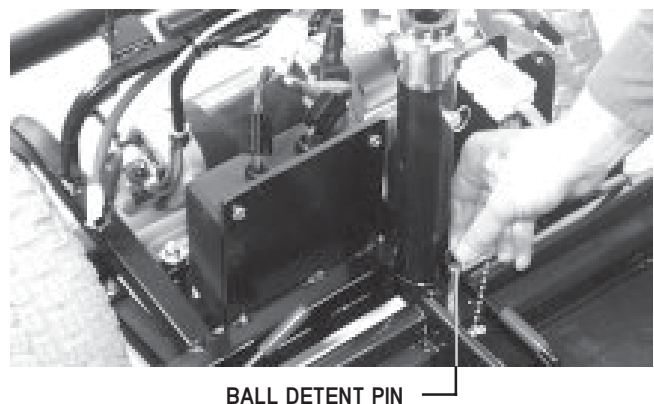

Figure 14. Ball Detent Pin

VIII. DISASSEMBLY AND ASSEMBLY

ASSEMBLY

1. Pull up on the manual freewheel lever. See IV. “Description.” Placing your Victory XL-8 in manual freewheel mode may make it easier for you to maneuver the rear section because the drive wheels are free to turn.
2. Position the front and rear sections of your Victory XL-8 as shown in figure 15.
3. Align the lower curved locking bracket slots on the rear of the front section to the corresponding pegs on the front of the rear section.
4. Gently push the front section of your Victory XL-8 toward the rear section until the curved locking brackets are fully connected onto the rear pegs.
5. Insert the ball detent pin.
6. Place the camlock levers in the locked position. See figure 16.
7. Raise the tiller to the upright position by turning the tiller adjustment lever until it is loose. Raise the tiller to the desired position. Verify the tiller release buttons are reengaged and tighten the tiller adjustment lever.
8. Connect the large, white, 9-pin front-to-rear connector (located on the harness coming out of the Victory XL-8’s front section) to the connector’s mating socket (found near the front of the Victory XL-8’s rear section).
9. Place the batteries in the battery wells, then reconnect the battery tie-down strap.
10. Connect the 2-pin battery harnesses into the mating harnesses that extend from the electronic controller module.
11. Gently place the rear shroud over the seat pedestal and slide it down into position. The reusable fasteners hold it in place.
12. Carefully lift the seat and slide the seat post (on the bottom of the seat frame) into the seat post tower.
13. Rotate the seat until it locks into place to complete the assembly of your Victory XL-8.

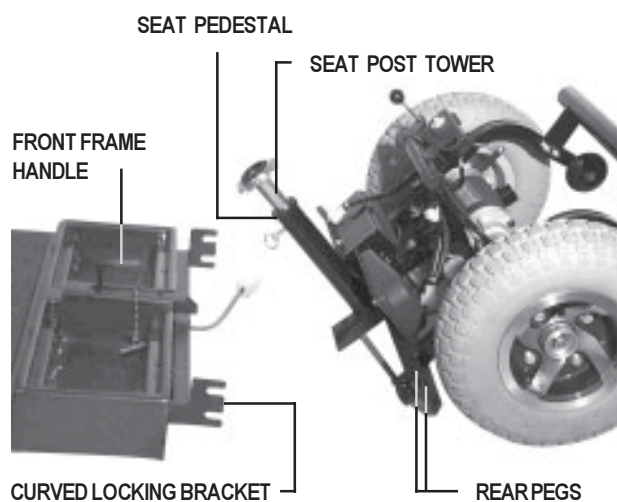

Figure 15. Separate Front and Rear Sections

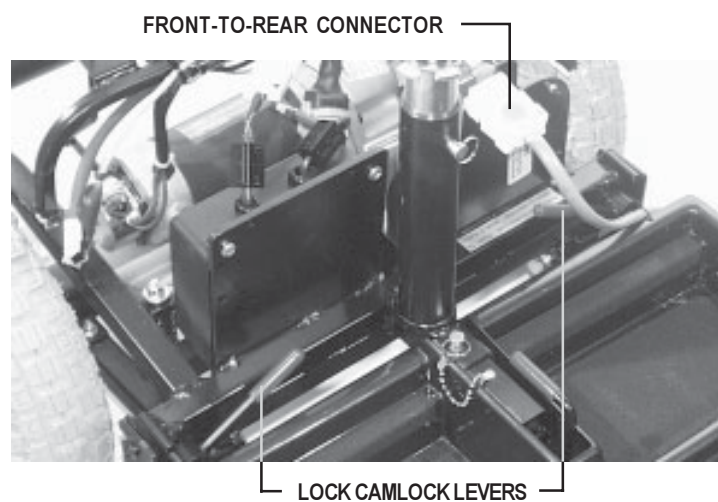

Figure 16. Lock Camlock Levers

IX. TROUBLESHOOTING

Any electromechanical device occasionally requires some troubleshooting. However, most of the problems that may arise can usually be solved with a bit of thought and common sense. Many of these problems occur because the batteries are not fully charged or because the batteries are worn down and can no longer hold a charge.

PROBLEM	POSSIBLE SOLUTIONS
All of my Scooter systems appear to be dead.	<p>One of the following actions may eliminate the problem.</p> <ul style="list-style-type: none"> • Ensure the key is fully inserted in the key switch and the key is turned clockwise. • Ensure the batteries are fully charged. • Push in the main circuit breaker reset button. • Ensure both battery harnesses are firmly connected to the electronic controller module and to the battery terminals. • Ensure the front-to-rear cable is firmly connected.
My Scooter does not move even though the motor runs.	<p>Ensure your Scooter was not left in manual freewheel mode. (Remove the key from the key switch and push down the manual freewheel lever to restore normal operation.)</p> <p><i>NOTE: When the manual freewheel lever is pulled up, your Victory XL-8's brakes and motor are disengaged from the transaxle.</i></p>
My Victory XL-8's main circuit breaker repeatedly trips.	<p>One of the following actions may eliminate the problem.</p> <ul style="list-style-type: none"> • Charge your Victory XL-8's batteries more frequently. • Have your authorized Pride provider load test each battery. • Obtain a battery load tester at most any automotive parts store; follow the directions supplied with the load tester.
My Victory XL-8's battery condition meter dips way down and the motor surges or hesitates when I press the throttle control lever.	<p>One of the following actions may eliminate the problem.</p> <ul style="list-style-type: none"> • Fully charge your Victory XL-8's batteries. • Have your authorized Pride provider load test each battery. • Obtain a battery load tester at most any automotive parts store; follow the directions supplied with the load tester.

If you experience any problems with your Victory XL-8 that you are not able to resolve, immediately contact your authorized Pride provider for information, maintenance, and service.

X . C A R E A N D M A I N T E N A N C E

Your Victory XL-8 requires a minimal amount of care and maintenance. If you do not feel confident in your ability to perform the maintenance listed below, you may schedule inspection and maintenance with your authorized Pride provider.

The following areas require periodic inspection and/or care and maintenance.

TYRE PRESSURE

- We recommend you maintain the tyre pressure at 30 psi for optimum Scooter performance.



WARNING! Overinflating a tyre can cause it to explode.

TYRE CONDITION AND TREAD WEAR

- Regularly inspect your Victory XL-8's tyres for signs of wear.
- Use a rubber conditioner on your Victory XL-8's tyres to preserve them.



WARNING! Do not put rubber conditioner on the tread area of tyres; the tyres may become dangerously slippery.

REMOVABLE FLOORMATS

- Your Victory XL-8's carpet floormat is held on with reusable fasteners and may be removed, cleaned, and reinstalled as necessary.

EXTERIOR SURFACES

- Bumpers and trim benefit from an occasional application of rubber or vinyl conditioner.



WARNING! Do not use rubber or vinyl conditioner on your Victory XL-8's vinyl seat; it may become dangerously slippery.

BATTERY TERMINAL CONNECTIONS

- Ensure the terminal connections remain tight and uncorroded.
- Ensure the batteries sit flat in the battery wells.
- Ensure the battery terminals face the rear of your Victory XL-8.

WIRING HARNESSES

- Regularly check all wiring connections.
- Regularly check all wiring insulation, including the charger power cord, for wear or damage.
- Repair or replace any damaged connector, connection, or insulation before you use your Victory XL-8.

X. CARE AND MAINTENANCE

ABS PLASTIC SHROUDS

- Apply a light coat of car wax to the shrouds to help retain their high gloss; the shrouds are formed from durable ABS plastic and are coated with an advanced formula urethane paint.

AXLE BEARINGS AND THE MOTOR/TRANSAXLE ASSEMBLY

- You do not need to lubricate these items, as they are all prelubricated and sealed.

CONSOLE, CHARGER, AND ELECTRONIC CONTROLLER MODULE

- Keep these areas away from moisture.
- Let any of these areas dry thoroughly before operating your Victory XL-8 if they have been exposed to moisture.

STORAGE

- Refer to “How should I store my Victory XL-8 and its batteries?” in V. “Batteries and Charging.”

XI. WARRANTY

TWO-YEAR LIMITED WARRANTY

Structural frame components, including: platform, fork, seat post, and frame welds.
Drive train, including: differential, motor, and brake.

ONE-YEAR LIMITED WARRANTY

Your Pride Scooter is fully guaranteed for twelve (12) months from the date of purchase against faults arising due to defects in manufacture or materials. This warranty does not detract from, but is in addition to, your legal rights.

All electronic parts, including controllers and battery chargers, have a one (1) year warranty. Servicing to the controller or battery charger must be carried out by your local Pride provider. Any attempt to open or dismantle these items renders the guarantee void on that item.

NOT COVERED UNDER WARRANTY

This guarantee does not extend to those items which may need replacement due to normal wear and tear (tyres, belts, bulbs, upholstery, plastic shrouds, motor brushes, fuses, and batteries), or damage to the product caused by misuse or accident for which Pride Mobility Products, Ltd., or its agent cannot be held responsible. This warranty does not include labor or service calls.

BATTERIES

Batteries are covered by a twelve (12) month warranty from the original manufacturer.

Gradual deterioration in performance due to being left in a discharged state, left in cold conditions for long periods of time, or worn out through heavy use is not covered.

SERVICE CHECKS AND WARRANTY SERVICE

Warranty service can be performed by an authorized Pride provider. Please contact your local Pride provider for advice on the current cost affecting the service visit.